

# ST chain hoists \_ many years of experience, innovative technology



STAHL CraneSystems | Lifting technology | Drive technology | Control technology



# Competence from STAHL CraneSystems

**Experienced** Over 130 years of tradition, over 130 years of practical approach, competence and experience. STAHL CraneSystems can look back on a history characterised by the constant impetus to innovation and significant modernisations. Revolutionary and programmatic in many fields, always receptive to new aspects, we have amassed a wealth of experience that gives us a considerable lead today. You as our customer profit from this lead, from the know-how of one of the world's top-ranking manufacturers of components and systems for overhead transportation. As regards technology and cost-effectiveness, our products belong to the top flight internationally. Our service is individual, customer- and practice-oriented.



- 1876** | Company founded by Raphael Stahl
- 1903** | First electric pulley block
- 1919** | The STAHL snake: a new type of chain flexible in all directions
- 1950** | The Elektus: the world's first small portable electric chain hoist
- 1982** | T series chain hoist
- 2002** | The new generation – ST series chain hoist
- 2004** | World innovation – the extra short headroom trolley

1876



1903



1919



1950



1982



2002



2004





04 \_ ST chain hoist

---



06 \_ Technical features

---

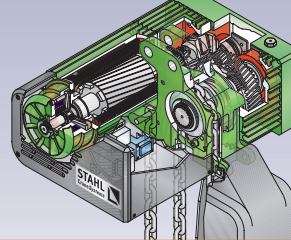

08 \_ [Extra] short headroom trolley

---



10 \_ STD dual chain hoist

---



12 \_ Off-standard solutions

---



14 \_ Explosion-protected chain hoists

---



15 \_ Service

---





1



2



3



4

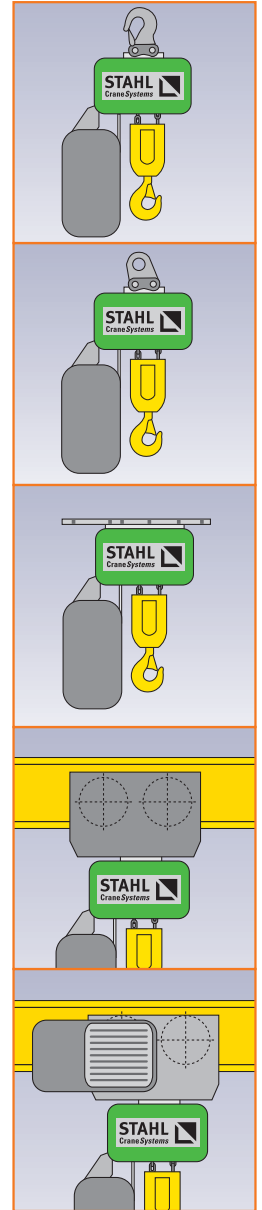

Hook

Eye

Rigid suspension

Push trolley

Electric trolley

1 The lightweight ST05 chain hoist with an S.W.L. of up to 630 kg is ideal for use in a small crane system.

2 Factory for hand-made paper \_ ST20 chain hoist handling paper reels.

3 The single-fall version of the ST50 chain hoist permits fast hoisting speeds for S.W.L.s up to 2500 kg.

4 The ST chain hoist with an S.W.L. of up to 6,300 kg.

# The ST chain hoist

## Reliable









































The ST chain hoist programme from STAHL CraneSystems ranks among the most distinctive and comprehensive on offer. In use in thousands of applications for many decades, modernised and optimised over and over again, this chain hoist is a classic. Powerful, reliable and undemanding as regards maintenance and power consumption. The ST series is available in 13 S.W.L. ranges, from 125 kg to 6,300 kg. It can be used as a stationary hoist with suspension hook or eye, with rigid mounting, or with a push or electric trolley, and is particularly suitable for rugged applications in industry. The innovative and pioneering chain hoist design offers considerable economic advantages. The extremely short headroom available as an alternative for every type of chain hoist optimises the effective hook height while keeping wear on the chain to a minimum. In addition

to the standard designs, off-standard versions and individual solutions for customers are available. The ST chain hoist programme from STAHL CraneSystems is also available in -protected design for Zone 1, Zone 21 and Zone 22. STAHL CraneSystems was the first hoist manufacturer to convert the whole chain hoist programme to ATEX.

- › **Professional** \_ patented suspension directly at the chain guide
- › **Perfect** \_ high-quality chain hoists from STAHL CraneSystems from our own production in Germany
- › **Meeting customer demands** \_ the most comprehensive chain hoist programme for S.W.L.s from 125 kg to 6,300 kg
- › **Safe** \_ all chain hoists are available in -protected design
- › **Powerful** \_ all chain hoists with two hoisting and two travel speeds
- › **Ideal** \_ maximum utilisation of space thanks to extremely short and compact headroom dimensions
- › **Long-lived** \_ particularly high standard classification in acc. with FEM
- › **Available fast** \_ thanks to modern Kanban production

 Standard

 Option

Type	S.W.L. [kg]	Stationary	Push trolley	Electric trolley	Dual chain hoist	Entertainment hoist	[Extra] short headroom trolley	Articulated trolley
ST 05	125 – 630							
ST 10	500 – 1,000							
ST 20	1,000 – 2,000							
ST 30	1,250 – 3,200							
ST 50	2,500 – 5,000							
ST 60	3,200 – 6,300							

# Perfect technology in detail

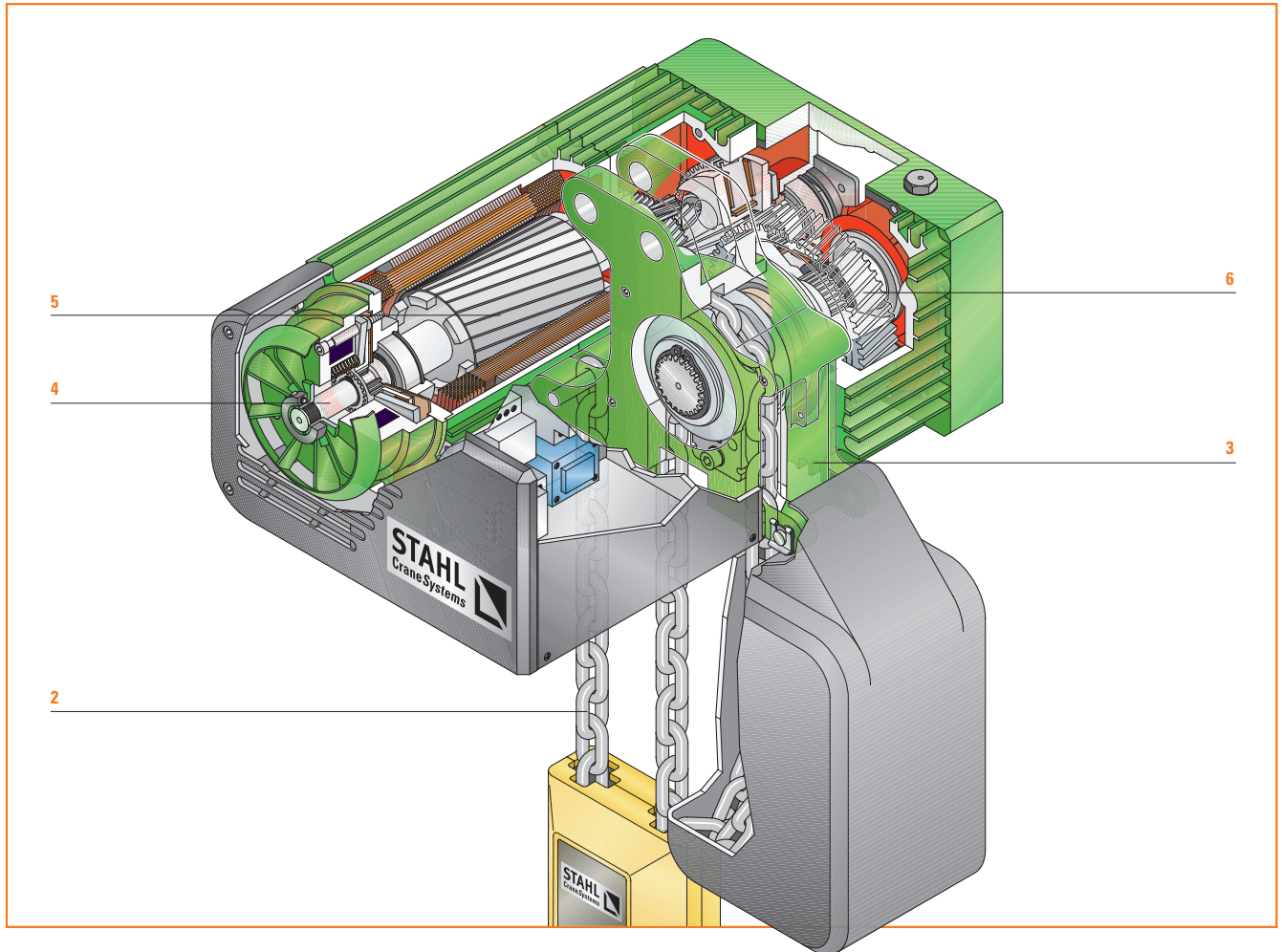

## 1 Control

- › All common control voltages available
- › Ergonomic STH control pendant
- › Control pendant and travel motor with plug-and-socket connections
- › Clear arrangement of contactors
- › Also available with direct control

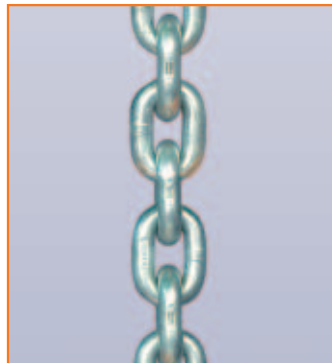

## 2 Chain

- › Surface-hardened, galvanised and generously dimensioned load chain
- › High effective hardening depth and optimised return sheaves guarantee minimum wear and long service life
- › High classification in acc. with FEM



### 3 Chain drive

- › Innovative and patented chain drive (DE 198 49 693 C2), anchorage and load-bearing components are directly integrated into the high-tensile grey cast iron element, there is thus no aluminium in the power flux
- › Simple inspection and replacement of the chain sprocket thanks to over-mounted shaft bearing
- › Enclosed chain guide, self-lubricating
- › Reliable functioning even in demanding applications
- › Wear-resistant case-hardened chain sprocket

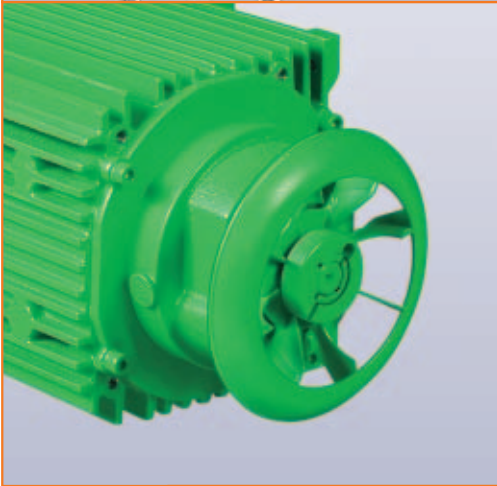

### 4 Brake

- › Low-maintenance, asbestos-free electromagnetic disc brake; no adjustment necessary
- › Oversized braking torque
- › Long-lived even with a high number of motor switching operations; brake wear can be checked and measured
- › Long service life
- › Brake completely enclosed, protected from humidity, vapours and dusts from outside; this guarantees it will function reliably over the long term

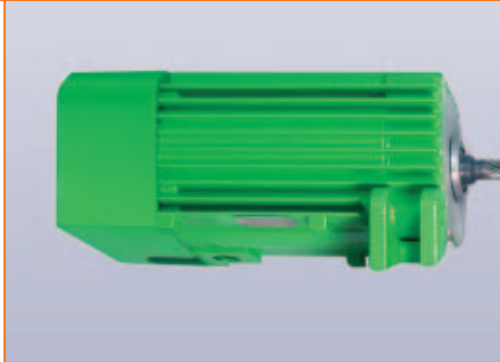

### 5 Motor

- › High standard classification in acc. with FEM
- › Powerful motors with high duty cycle and number of switching operations ensured by standard fan cooling
- › Two hoisting speeds as standard
- › Single-speed and four-pole versions are available as options



### 6 Overload slipping clutch and gear

- › On the ST10 – ST63, the slipping clutch is situated in the oil-cooled gear and is designed for long starting phases with no danger of “burning out”.
- › For motor outputs of 0.8 kW – 3.8 kW the energy is reliably dissipated as heat in the slowly rotating gear step
- › No electronic limiting necessary
- › Innovative materials
- › Various gear reductions available thanks to the modular system



1

- 1 | The short headroom trolley; this patented design reduces headroom by approx. 33% and permits exceptional heights of lift, particularly in low-ceilinged rooms.
- 2 | Metal-working shop – The single girder suspension crane mounted directly on the ceiling and the patented construction of the ST chain hoist series save valuable headroom.
- 3 | Maintenance shop – Here every millimetre of effective hook height is decisive. With the ST chain hoist, heavy loads can be transported safely even in this low-ceilinged room.
- 4 | Extra short headroom trolley – The ST50 chain hoist from STAHL CraneSystems with an S.W.L. of up to 5,000kg. In this version, the headroom is reduced by more than 60%.



4

2



3





# The [extra] short headroom trolley

## Progressive

STAHl CraneSystems sets new standards with the STK extra short headroom trolley. The construction of the short headroom trolley itself saves a tremendous amount of space. The body of the chain hoist is mounted at an angle, meaning that no return sheave is required. The extra short headroom trolley with its headroom reduced by 60% achieves maximum hook paths particularly in extremely low-ceilinged rooms. It fully deserves its name, the dimensions of a mere 210 mm with 5,000 kg S.W.L. and 185 mm with 3,200 kg S.W.L. are extremely low and cannot be beaten at present. The chain hoists used here, mounted vertically, are based on the standard ST chain hoist programme from STAHl CraneSystems. The patented chain drive is unique. The hook suspended in the centre is driven evenly by two chains running synchronously. The load is lifted without swinging or vibrating. The STK chain hoist programme for the S.W.L. range from 125 kg to 6,300 kg is naturally also available in explosion-protected design for Zone 1, Zone 21 and Zone 22.

- › **Extreme** \_ minimum space requirement for maximum height of lift
- › **Ingenious** \_ patented chain guide with integrated suspension, the load is lifted smoothly and without swinging
- › **Compact** \_ low dimensions, low deadweight
- › **Cost-effective** \_ practically maintenance free, using the tried and tested chain hoist from the standard ST programme
- › **Smooth** \_ trolleys with no projecting edges for steady cross travel
- › **Safe** \_ in -protected design

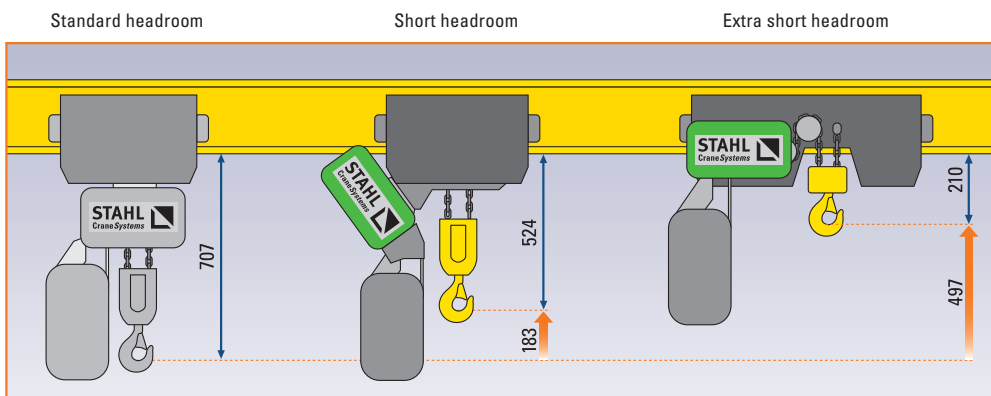

The dimensions are applicable for an ST chain hoist with an S.W.L. of 5,000 kg and standard 3 m height of lift.



1

- 1 | Low-swing transport of long goods 10 t in weight by four coupled load hooks. This solution was realised with two dual chain hoists.
- 2 | At John Deere in Mannheim, tractor radiators are transported to the assembly line using STD dual chain hoists.  
→ Ask for our reference brochure „Tractor radiator assembly“!
- 3 | In Büttenpapierfabrik Gmund STD dual chain hoists ensure safe handling of heavy paper reels.
- 4 | Perfect teamwork of dual chain hoists with original crane technology from STAHL CraneSystems: here suspension cranes are in operation.



2



3



4

# The dual chain hoist

**Synchronous** The STD dual chain hoist from STAHL CraneSystems combines many advantages. It is reliable, cost-effective and low-maintenance, as all components come from the standard ST programme, and offers unique space advantages; the short headroom guarantees maximum hook paths even in low-ceilinged rooms. The STD dual chain hoist from STAHL CraneSystems has two load chains which enable the two hooks to be driven by a single hoist motor. Long goods and loads which must be taken up at two points are thus lifted, transported and accurately positioned without tilting. Even if the loading is uneven, these load chains run completely in parallel. The distance between the hooks is individually adapted to the goods to be transported. There are two versions of the STD dual chain hoist available. Either both load hooks are on one side of the chain hoist, or to left and right of the chain hoist. The STD dual chain hoist is available as an option in explosion-protected design for Zone 1, Zone 21 and Zone 22.

- › **Compact** \_ minimum space requirement for maximum height of lift
- › **Synchronous** \_ one hoist, two hook lead-offs
- › **Precise** \_ synchronous even with uneven loading, no load swing
- › **Individual** \_ two versions, adapted to the width of the load
- › **Cost-effective** \_ practically maintenance free, using the tried and tested chain hoist from the standard ST programme
- › **Safe** \_ in -protected design

„E” design

„Z” design

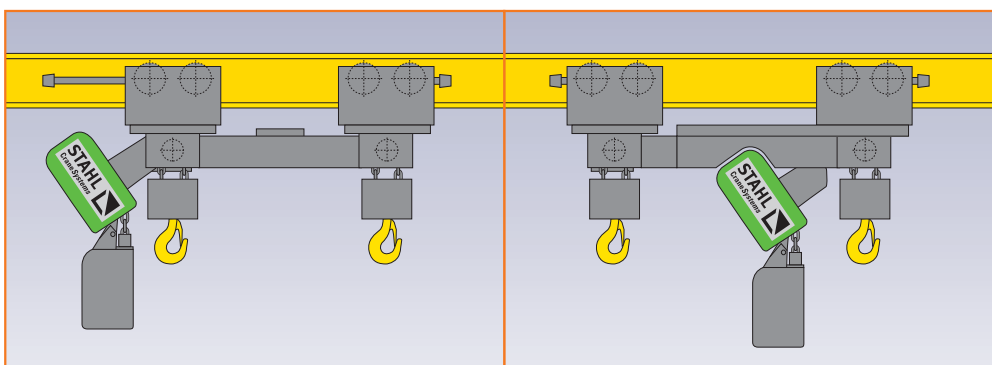



1

1 | Wind power stations – ST 10 chain hoist with chain box and pocket for control pendant. Hoisting speeds of up to 32 m/min for heights of lift up to 150 m.

➔ Ask for our reference brochure „Wind power stations“!

2 | Redundant design – Double safety from two brakes and dual chain drive. Our solution for work on and under the suspended load.

3 | Double safety with two independent brakes. A bypass gear makes the brake directly effective on the load; the bypassed slipping clutch is situated in the slowly rotating gear step and cooled by the gear oil.

4 | Big Bag handling – Lifting Big Bag beams up to highest hook position without any projecting edges.

➔ Ask for our Product Information!



2

5 | Synchronous lifting for four-point load take-up by means of coupling the chain hoists.

6 | Big Bag handling – Equipped with modern radio remote controls for operating the chain hoists safely and conveniently.

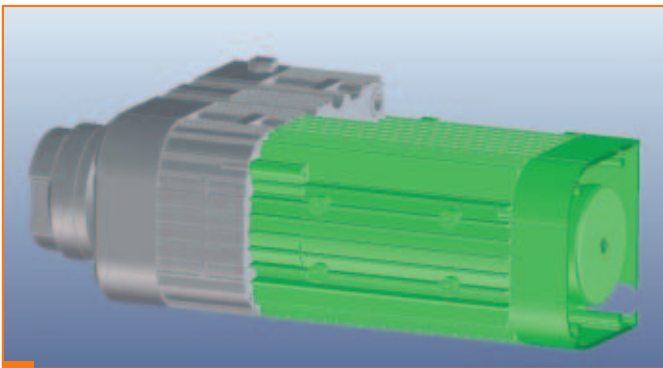

3

4

5



6

# Off-standard chain hoist solutions

**Individual** The ST range of chain hoists from STAHL CraneSystems is the basis for many off-standard solutions. The solutions on offer extend from chain hoists with extremely low headrooms, twin chain hoists, chain hoists for the entertainment industry, Big Bag designs, coupled chain hoists for four-point load take-up or multi-fall chain hoists, to various trolleys, to customer-specific solutions.

These tasks can be solved flexibly with STAHL CraneSystems' modular chain hoist technology.

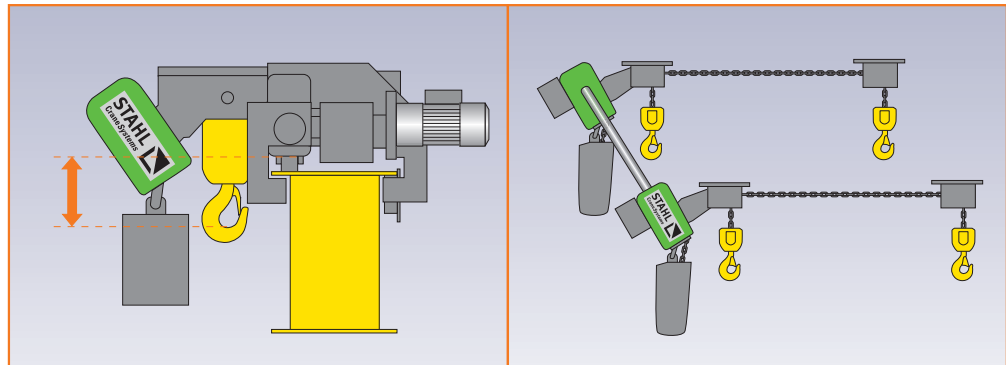

Cantilever crab

Coupled chain hoists for four-point load take-up

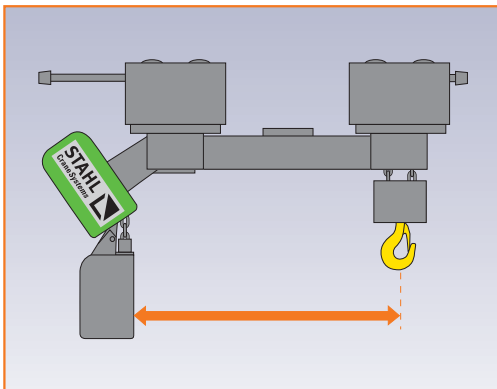

Big Bag design

**Big Bag design** The new Big Bag design from STAHL CraneSystems was developed from the STD dual chain hoist programme with its many advantages. Compact construction, low headroom, patented chain guide with integrated, safe suspension, standardised, low-maintenance components and short delivery times are just a few of these. Outstanding special features are free choice of the distance between chain hoist and load hook and lifting bulky loads up to top hook position without any hindering edges such as trolley, chain hoist or chain box. The Big Bag design is available for S.W.L.s up to 3,200 kg and also in explosion-protected version.

**Entertainment hoists** Electric hoists used in theatrical performance and production areas are subject in Germany to the strict accident prevention regulations of the Employers' Liability Insurance Association. The ST chain hoist programme has been certified by the Employers' Liability Insurance Association in acc. with BGV D8 and BGV C1. Thus S.W.L.s of 125 kg to 2,500 kg with various hoisting speeds can be supplied meeting BGV C1. Over and above this, STAHL CraneSystems' specialists can design and programme complex systems in collaboration with competent partners.

Hoists for the entertainment industry in acc. with BGV C1

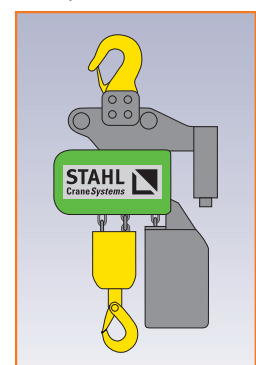

- 1 The ST chain hoist in explosion-protected design is available in two frame sizes up to an S.W.L. of 5,000 kg.
- 2 In a chemical plant a single girder suspension crane of 1,600 kg S.W.L. is used for transporting system parts during maintenance work outdoors. The slim construction of the explosion-protected chain hoist permits optimum utilisation of the whole width of the crane bridge.



# Explosion-protected chain hoists



ATEX

**Extreme** STAHL CraneSystems is pioneering, dynamic and uncompromising when the safety of persons and machines in areas subject to gas and explosion hazards is at stake. All around the world, STAHL CraneSystems is regarded as a specialist for explosion protection. STAHL CraneSystems occupies a prominent position in this field with our many decades of experience and know-how, our own fundamental research and development, approvals from the Federal Physico-Technical Institute (PTB) and other test institutes in many countries. All components of STAHL chain hoists without exception come from our own production, from motor and brake to controls and control pendant. This ensures maximum and high-quality explosion protection. Naturally the new, strict ATEX regulations on mechanical explosion protection are met. STAHL CraneSystems was the first manufacturer of overhead material flow technology to implement the ATEX 100a directive 94/9 in the whole production range.

- **Experienced** \_ the world's leading specialist for explosion protection technology
- **Uncompromising** \_ everything from a single supplier and our own production
- **Pioneering** \_ Design and maintenance in compliance with ATEX in certified quality
- **Complete** \_ the world's first and only full hoist range for Zone 1, Zone 21 and Zone 22

# Customer services \_ all around the world, right around the clock

## Responsible

STAHL CraneSystems is a by-word for safety, confidence and cost-effectiveness. Our responsibility is to you, our customer. Specialists trained by us advise you on which hoists are right for your application. Planning, calculation and order processing are fast. The lasting safety and cost-effectiveness of your hoists and small crane systems are important to us at STAHL CraneSystems. In this too, qualified and competent service engineers, trained by us, look after your system throughout its service life, all around the world and right around the clock. Our services extend from world-wide prompt spare parts supply to individual, system-orientated maintenance using modern diagnostic apparatus, to annual inspections to ensure national accident prevention regulations are met. Training courses and seminars in our own training centre also form part of the extensive services offered by STAHL CraneSystems. We help your staff to keep up to speed.

- **On the spot** \_ 13 subsidiaries and over 100 partner companies around the world
- **Perfect** \_ Everything from one qualified supplier, STAHL CraneSystems
- **Competent** \_ Regular training courses for service engineers held by STAHL CraneSystems in our own training centre  
➔ [training@stahlcranes.com](mailto:training@stahlcranes.com)
- **Progressive** \_ Condition monitoring devices ensure safe operation, modern diagnostic apparatus permits customised service to be offered for the whole crane
- **Round the clock** \_ Online service for partners  
➔ [www.web.stahlcranes.com](http://www.web.stahlcranes.com)
- **Guaranteed** \_ Spare parts supply even decades after the series has been discontinued
- **Fast** \_ The electronic spare parts catalogue is a new medium for ordering spare parts

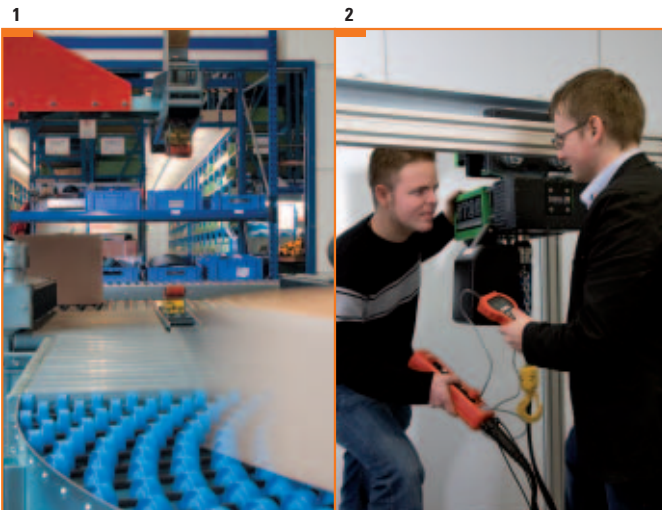

- 1 | Central spare parts warehouse in the Künzelsau-Hofratsmühle plant.
- 2 | Modern diagnostic apparatus assists service engineers during inspection and maintenance work.
- 3 | The electronic spare parts catalogue is a new medium for ordering spare parts.
- 4 | Regular training and information for service staff in the training centre.

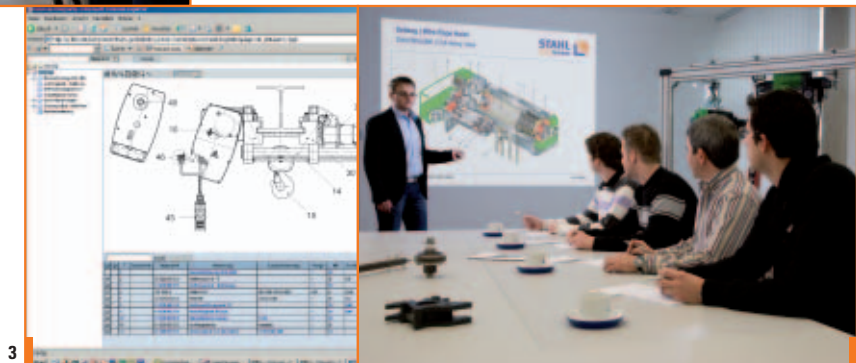

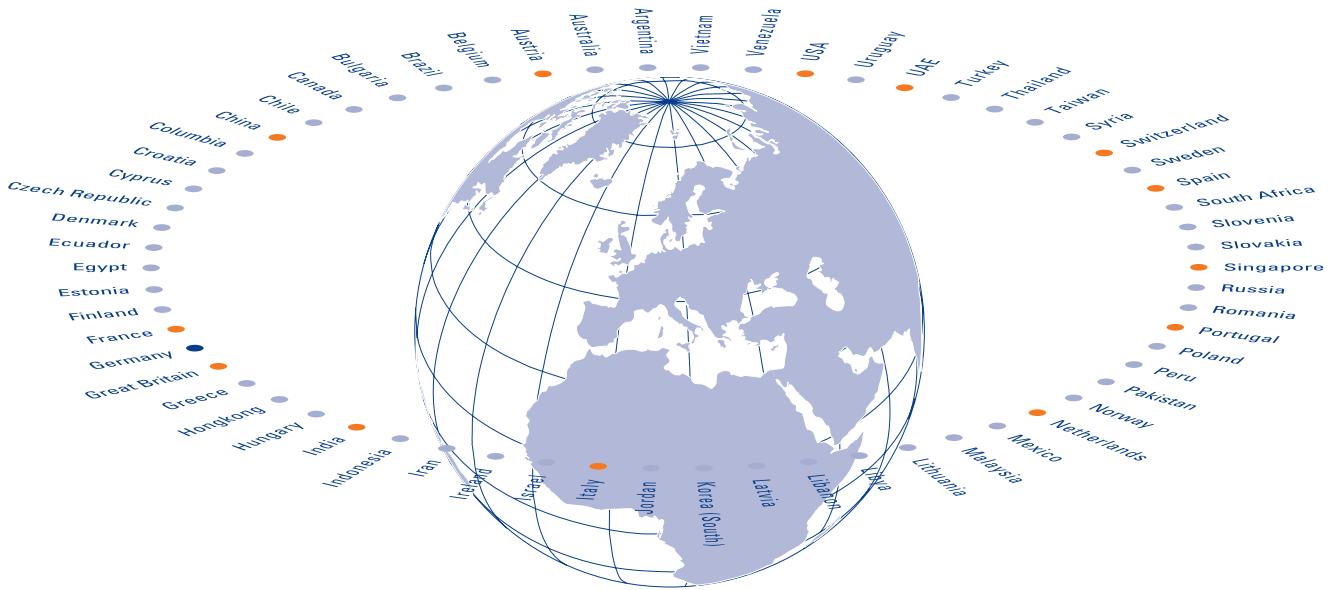

**● Subsidiaries**

**Austria**  
Steyregg  
Tel +43 732 641111-0  
Fax +43 732 641111-33  
office@stahlcranes.at

**India**  
Chennai  
Tel +91 44 43523955  
Fax +91 44 43523957  
anand@stahlcranes.in

**Singapore**  
Singapore  
Tel +65 6271-2220  
Fax +65 6377-1555  
sales@stahlcranes.sg

**USA**  
Charleston, SC  
Tel +1 843 767-1951  
Fax +1 843 767-4366  
sales@stahlcranes.us

**China**  
Shanghai  
Tel +86 21 62572211  
Fax +86 21 62541907  
victor.low@stahlcranes.cn

**Italy**  
S. Colombano  
Tel +39 0185 358391  
Fax +39 0185 358219  
info@stahlcranes.it

**Spain**  
Madrid  
Tel +34 91 4840865  
Fax +34 91 4905143  
info@stahlcranes.es

**France**  
Paris  
Tel +33 1 39985060  
Fax +33 1 34111818  
info@stahlcranes.fr

**Netherlands**  
Haarlem  
Tel +31 23 51252-20  
Fax +31 23 51252-23  
info@stahlcranes.nl

**Switzerland**  
Däniken  
Tel +41 62 82513-80  
Fax +41 62 82513-81  
info@stahlcranes.ch

**Great Britain**  
Birmingham  
Tel +44 121 7676414  
Fax +44 121 7676490  
info@stahlcranes.co.uk

**Portugal**  
Lisbon  
Tel +351 21 44471-61  
Fax +351 21 44471-69  
ferrometal@ferrometal.pt

**United Arab Emirates**  
Dubai  
Tel +971 4 8053700  
Fax +971 4 8053701  
info@stahlcranes.ae

**● Sales partners**

You will find the addresses of over 100 sales partners on the Internet at [www.stahlcranes.com](http://www.stahlcranes.com) under Contact

➔ [www.stahlcranes.com](http://www.stahlcranes.com)

STAHL CraneSystems GmbH, Daimlerstr. 6, 74653 Künzelsau, Germany  
Tel +49 7940 128-0, Fax +49 7940 55665, [marketing@stahlcranes.com](mailto:marketing@stahlcranes.com)

