

# КранСталь

**DE** Explosionsgeschützte Krankomponenten (ATEX)\_  
Originalteileliste

**EN** Explosion-protected crane components (ATEX)\_  
Original parts list



KEH  
KEL  
KZL  
FE-A



FU-B ex  
SF ex  
SA-D ex  
Zone 1

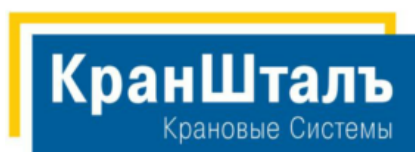
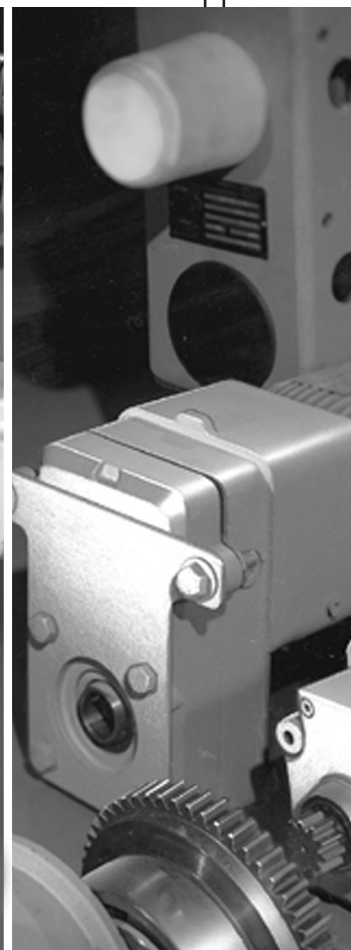
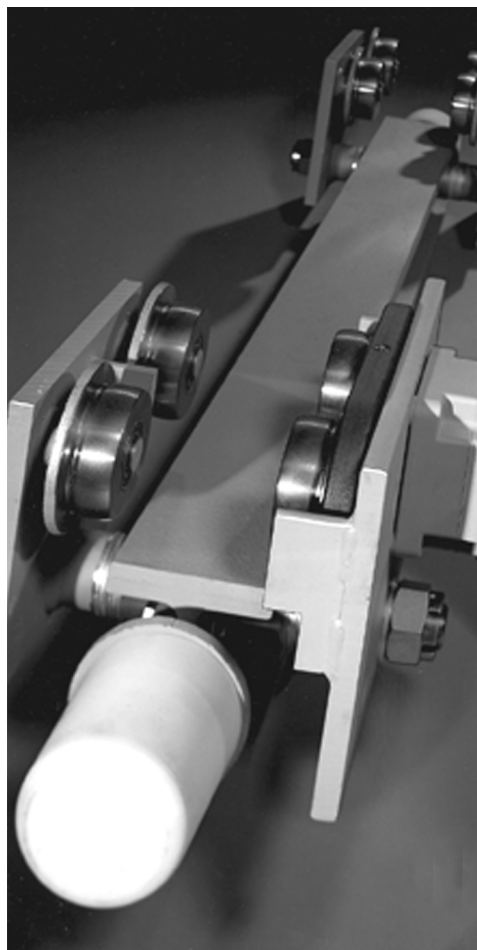

<http://kranstahl.ru>  
[info@kranstahl.ru](mailto:info@kranstahl.ru)

Partner of



+7 (495) 225-37-88



## Notizen Notes

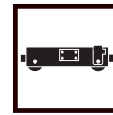

<b>Krankopfträger</b>		<b>Crane endcarrige</b>	
KEH-A080 .....	4	KEH-A080 .....	4
KEH-A100 .....	6	KEH-A100 .....	6
KEH-A125 .....	8	KEH-A125 .....	8
KEH-A160 .....	10	KEH-A160 .....	10
KEH-B080 .....	12	KEH-B080 .....	12
KEL-S125 .....	13	KEL-S125 .....	13
KEL/KZL-S160 .....	14	KEL/KZL-S160 .....	14
KEL/KZL-S200 .....	15	KEL/KZL-S200 .....	15
KEL/KZL-S315 .....	16	KEL/KZL-S315 .....	16
KZL-C400 .....	17	KZL-C400 .....	17
KZL-F500 .....	18	KZL-F500 .....	18
FE-A315 .....	19	FE-A315 .....	19
FE-A400 .....	20	FE-A400 .....	20
<b>Fahrertriebe</b>		<b>Travel drives</b>	
FU-B .....	21	FU-B .....	21
Fahrmotore .....	25	Travel motors .....	25
Schwungradkupplung .....	33	Flywheel coupling .....	33
Getriebe SF. ....	37	Gear SF. ....	37
Getriebe SA-D .....	43	Gear SA-D .....	43
Drehmomentstütze .....	47	Torque support .....	47

Austausch und Reparaturen nur von geschultem Personal ausführen lassen.

Die Angaben in der Spalte "Benennung" dienen nur internen Vorgängen.

Replacement and repairs may only be carried out by trained personnel.

The information in the column "Designation" is only for internal use.

**Bitte immer die Fabrik-Nr. angeben.**

**Please always state serial number.**

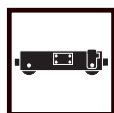

**Originalteile**  
**Original parts**  
**KEH-A080**

Austausch und Reparaturen nur von geschultem Personal ausführen lassen.

Replacement and repairs may only be carried out by trained personnel.

Die Angaben in der Spalte "Benennung" dienen nur internen Vorgängen.

The information in the column "Designation" is only for internal use.

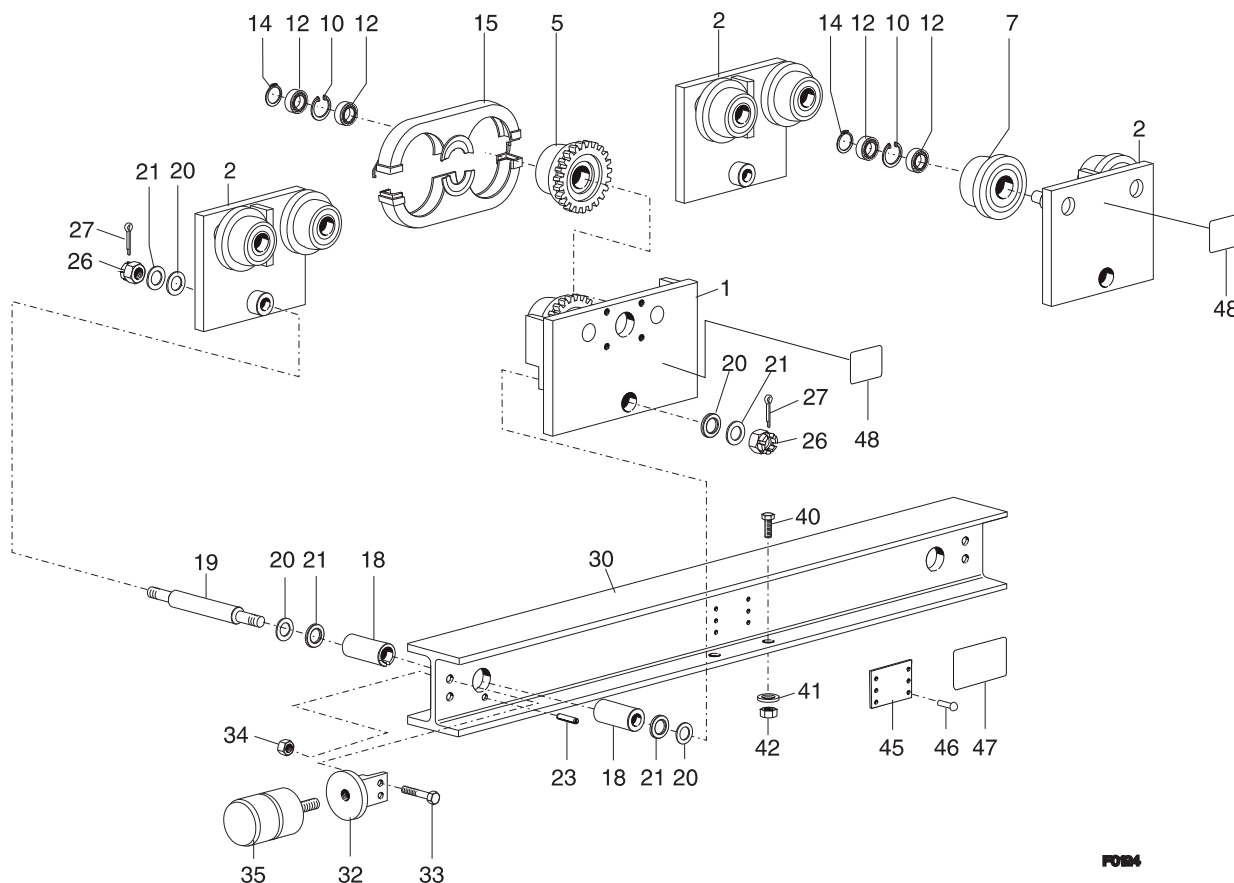

FORM

Pos	Teil-Nummer Part-Number	Stück Piece	Beschreibung Description	Benennung	Designation
1	23 720 00 25 0	1		Fahrwerkschild	Carriage side plate
2	23 720 01 25 0	3		Fahrwerkschild	Carriage side plate
5	03 250 02 40 0	2	A80 (Pos.10+12)	Laufrolle	Wheel
7	03 250 02 41 0	6	B80 (Pos.10+12)	Laufrolle	Wheel
10	506 105 0	8	42x1,75 DIN 472	Sicherungsring	Locking ring
12	560 950 0	16	6004-2RS DIN 625	Rillenkugellager	Grooved ball bearing
14	506 095 0	8	20x1,2 DIN 471	Sicherungsring	Locking ring
15	03 254 02 40 0	2		Laufrollenabdeckung	Wheel cover





Pos	Teil-Nummer Part-Number	Stück Piece	Beschreibung Description	Benennung Designation	Designation	
18	23 722 07 50 0	4	55/41/25,2	Buchse	Bushing	
	23 722 08 50 0	4	55/41/49,2			
	23 722 09 50 0	4	55/41/70,2			
	23 722 10 50 0	4	55/41/93,2			
	23 722 11 50 0	4	55/41/123,2			
19	23 722 06 92 0	2	73 mm - 110 mm 1)	Aufhängebolzen	Suspension bolt	
	23 722 07 92 0	2	113 mm - 154 mm 1)			
	23 722 08 92 0	2	155 mm - 193 mm 1)			
	23 722 09 92 0	2	200 mm - 240 mm 1)			
	23 722 10 92 0	2	260 mm - 300 mm 1)			
20	23 722 00 52 0	8	1,5 mm	Scheibe	Disc	
21	04 245 03 03 0	32	3 mm	Scheibe	Disc	
23	504 082 0	2	8x30	ISO 8752	Spannstift	Dowel pin
26	506 917 0	4	M30x1,5	DIN 935	Kronenmutter	Castellated nut
27	504 061 0	4	6,3x50	DIN 94	Splint	Cotter pin
30	23 722 00 26 0	1	KEH-A 08010		Kopfträgerprofil	End carriage profile
	23 722 01 26 0	1	KEH-A 08018			
	23 722 02 26 0	1	KEH-A 08025			
32	23 722 01 85 0	2		Pufferbefestigung	Buffer fastening	
33	500 303 0	4	M12x40	DIN 933-8.8	Skt-Schraube	Hexagon head cap screw
34	506 550 0	4	M12	DIN 934	Skt-Mutter	Hexanal nut
35	577 416 0	2			Kranpuffer	Buffer
40	501 110 0	4	M12x60		Sicherungsschraube	Locking screw
41	23 722 06 50 0	4	25/13/8		Buchse	Bushing
42	507 840 0	4	M12		Sicherungsmutter	Locking nut
45	23 720 00 80 0	1		(Pos.46)	Typenschild	Type plate
46	507 831 0	2	3x51		Blindniet	Blind rivet
47	23 722 01 42 0	1			Hinweisschild	Information sign
48	23 722 00 42 0	2			Hinweisschild	Information sign

1) Flanschbreite

1) Flange width



**Originalteile**  
**Original parts**  
**KEH-A100**

Austausch und Reparaturen nur von geschultem Personal ausführen lassen.

Replacement and repairs may only be carried out by trained personnel.

Die Angaben in der Spalte "Benennung" dienen nur internen Vorgängen.

The information in the column "Designation" is only for internal use.

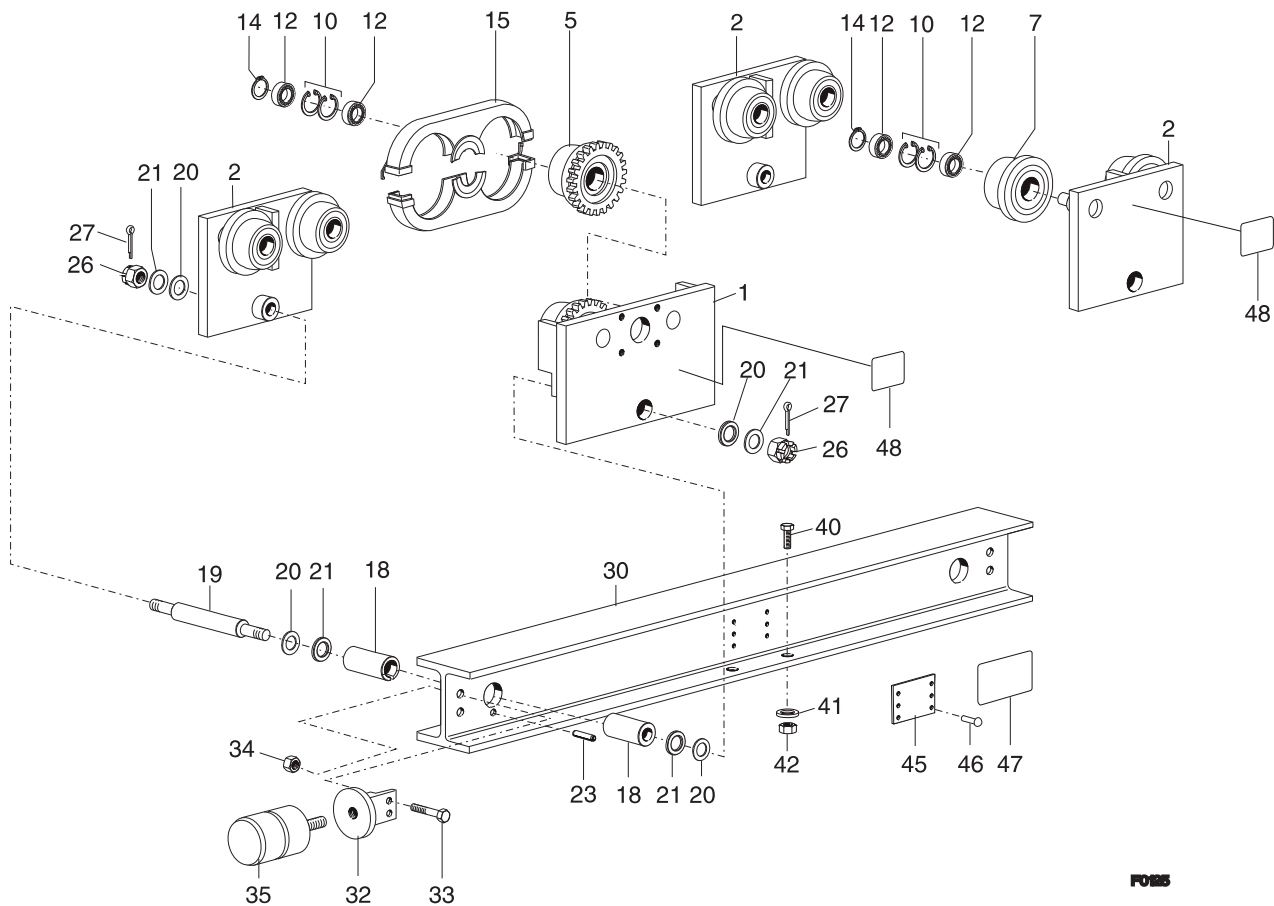

FOSS

Pos	Teil-Nummer Part-Number	Stück Piece	Beschreibung Description	Benennung	Designation
1	24 720 00 25 0	1		Fahrwerkschild	Carriage side plate
2	24 720 01 25 0	3		Fahrwerkschild	Carriage side plate
5	04 250 03 40 0	2	A100	Laufrolle	Wheel
7	04 250 02 41 0	6	B100	Laufrolle	Wheel
10	506 263 0	16	55x2	Sicherungsring	Locking ring
12	560 936 0	16	6006-2Z	Rillenkugellager	Grooved ball bearing
14	506 098 0	8	30x1,5	Sicherungsring	Locking ring
15	04 254 02 40 0	2		Laufrollenabdeckung	Wheel cover



Pos	Teil-Nummer Part-Number	Stück Piece	Beschreibung Description	Benennung Designation	Designation	
18	24 722 06 50 0	4	65/49/20,2	Buchse	Bushing	
	24 722 07 50 0	4	65/49/44,2			
	24 722 08 50 0	4	65/49/65,2			
	24 722 09 50 0	4	65/49/88,2			
	24 722 10 50 0	4	65/49/118,2			
19	24 722 05 92 0	2	66 mm - 110 mm 1)	Aufhängebolzen	Suspension bolt	
	24 722 06 92 0	2	113 mm - 154 mm 1)			
	24 722 07 92 0	2	155 mm - 193 mm 1)			
	24 722 08 92 0	2	200 mm - 240 mm 1)			
	24 722 09 92 0	2	260 mm - 300 mm 1)			
20	24 722 00 52 0	8	1,5 mm	Scheibe	Disc	
21	24 722 01 52 0	32	3 mm	Scheibe	Disc	
23	504 082 0	2	8x30	ISO 8752	Spannstift	Dowel pin
26	506 038 0	4	M36x1,5	DIN 935	Kronenmutter	Castellated nut
27	504 829 0	4	6,3x63	DIN 94	Splint	Cotter pin
30	24 722 00 26 0	1	KEH-A 10010	Kopfträgerprofil	End carriage profile	
	24 722 01 26 0	1	KEH-A 10025			
32	23 722 01 85 0	2		Pufferbefestigung	Buffer fastening	
33	500 303 0	4	M12x40	DIN 933-8.8	Skt-Schraube	Hexagon head cap screw
34	506 550 0	4	M12	DIN 934	Skt-Mutter	Hexanal nut
35	577 416 0	2		Kranpuffer	Buffer	
40	501 111 0	4	M16x70	Sicherungsschraube	Locking screw	
41	23 722 02 52 0	4	36/17/8	Buchse	Bushing	
42	507 840 0	4	M16	Sicherungsmutter	Locking nut	
45	23 720 00 80 0	1		(Pos.46)	Typenschild	Type plate
46	507 841 0	2	3x5	Blindniet	Blind rivet	
47	23 722 01 42 0	1		Hinweisschild	Information sign	
48	23 722 00 42 0	2		Hinweisschild	Information sign	

1) Flanschbreite

1) Flange width

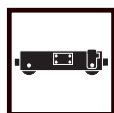

**Originalteile**  
**Original parts**  
**KEH-A125**

Austausch und Reparaturen nur von geschultem Personal ausführen lassen.

Replacement and repairs may only be carried out by trained personnel.

Die Angaben in der Spalte "Benennung" dienen nur internen Vorgängen.

The information in the column "Designation" is only for internal use.

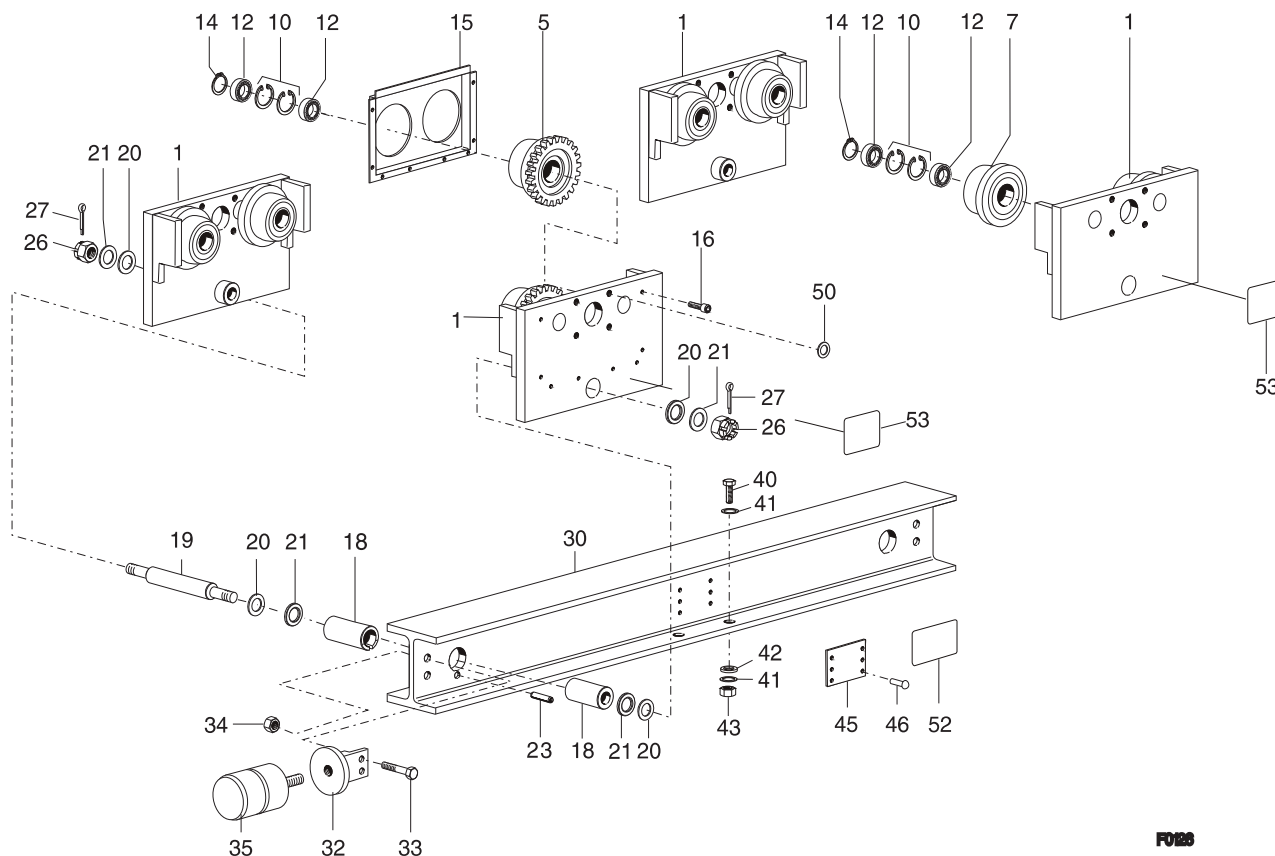

F0123

Pos	Teil-Nummer Part-Number	Stück Piece	Beschreibung Description	Benennung	Designation
1	25 720 00 25 0	4		Fahrwerkschild	Carriage side plate
5	05 250 03 40 0	2	A125	Laufrolle	Wheel
7	05 250 02 41 0	6	B125	Laufrolle	Wheel
10	506 108 0	16	62x2	Sicherungsring	Locking ring
12	560 989 0	16	6007-2Z	Rillenkugellager	Grooved ball bearing
14	506 099 0	8	35x1,5	Sicherungsring	Locking ring
15	05 254 02 40 0	1		Laufrollenabdeckung	Wheel cover
16	505 009 0	8	ST4,8x38	Blechschrabe	Screw



Pos	Teil-Nummer Part-Number	Stück Piece	Beschreibung Description	Benennung	Designation
18	25 722 03 50 0	4	88,9/71,3/37,5	Buchse	Bushing
	25 722 04 50 0	4	88,9/71,3/83,5		
19	25 722 02 92 0	2	119 mm - 210 mm 1)	Aufhängebolzen	Suspension bolt
	25 722 03 92 0	2	215 mm - 300 mm 1)		
20	25 722 00 52 0	68	3 mm	Scheibe	Disc
21	25 722 01 52 0	4	7,5 mm	Scheibe	Disc
23	504 961 0	2	10x40	Spannstift	Dowel pin
				ISO 8750	
26	506 039 0	4	M48x1,5	Kronenmutter	Castellated nut
27	504 126 0	4	8x80	Splint	Cotter pin
				DIN 935	
				DIN 94	
30	25 722 00 26 0	1	KEH-A 125	Kopfträgerprofil	End carriage profile
32	23 722 01 85 0	2		Pufferbefestigung	Buffer fastening
33	500 303 0	4	M12x40	Skf-Schraube	Hexagon head cap screw
34	506 550 0	4	M12	Skf-Mutter	Hexanal nut
35	577 416 0	2		Kranpuffer	Buffer
				DIN 933-8.8	
				DIN 934	
40	502 966 0	4	M20x80	Skf-Schraube	Hexagon head cap screw
41	507 064 0	12	21	Scheibe	Disc
42	25 722 02 52 0	4	42/21/10	Scheibe	Disc
43	501 070 0	4	M20	Skf-Mutter	Nut
45	23 720 00 80 0	1		Typenschild	Type plate
46	507 841 0	2	3x5	Blindniet	Blind rivet
				(Pos.46)	
50	45 342 00 52 0	4	25/11/5	Beilagscheibe	Disc
52	23 722 01 42 0	1		Hinweisschild	Information sign
53	23 722 00 42 0	2		Hinweisschild	Information sign

1) Flanschbreite

1) Flange width



**Originalteile**  
**Original parts**  
**KEH-A160**

Austausch und Reparaturen nur von geschultem Personal ausführen lassen.

Replacement and repairs may only be carried out by trained personnel.

Die Angaben in der Spalte "Benennung" dienen nur internen Vorgängen.

The information in the column "Designation" is only for internal use.

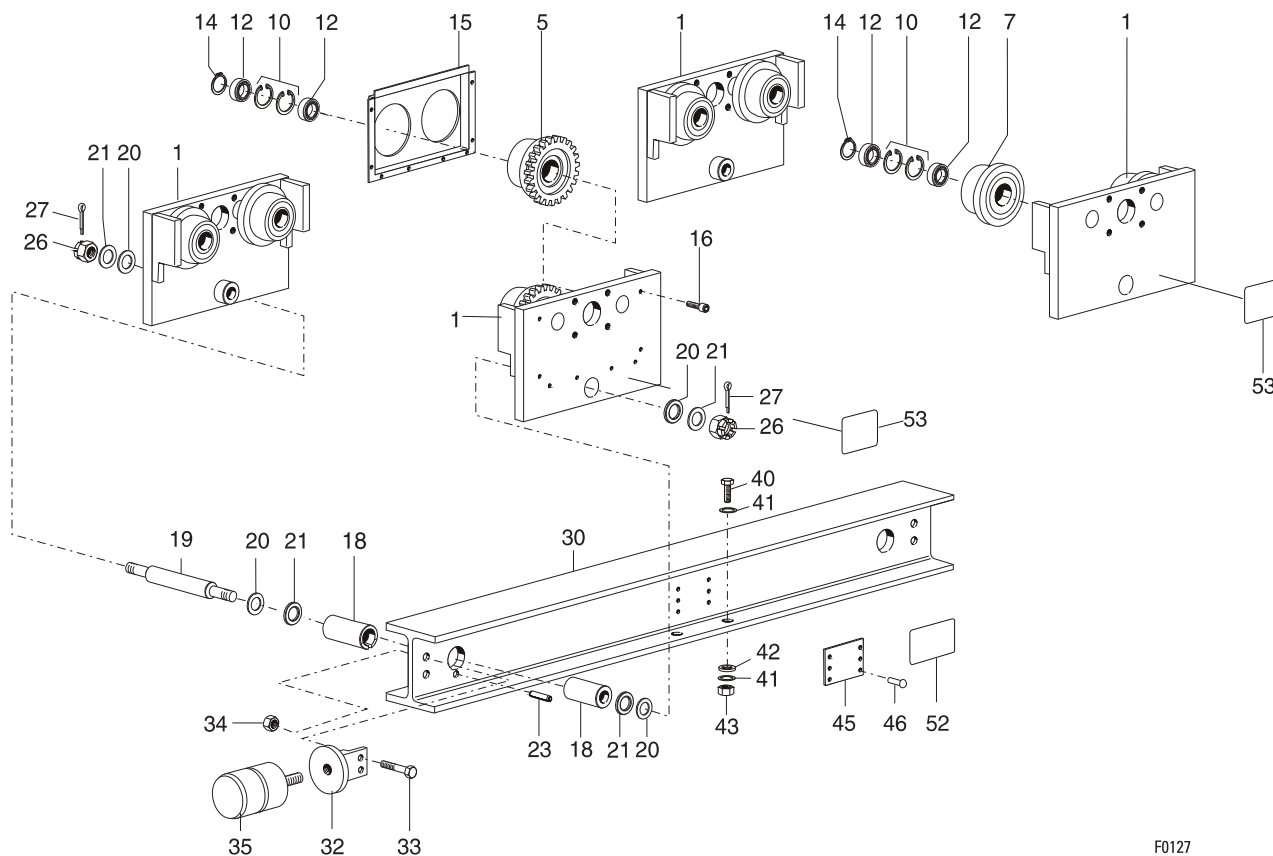

F0127

Pos	Teil-Nummer Part-Number	Stück Piece	Beschreibung Description	Benennung	Designation
1	26 720 00 25 0	4		Fahrwerkschild	Carriage side plate
5	06 250 03 40 0	2	A160	Laufrolle	Wheel
7	06 250 03 41 0	6	B160	Laufrolle	Wheel
10	506 254 0	16	80x2,5	Sicherungsring	Locking ring
12	560 005 0	16	6208-2Z	Rillenkugellager	Grooved ball bearing
14	506 247 0	8	40x1,75	Sicherungsring	Locking ring
15	06 254 04 40 0	2		Laufrollenabdeckung	Wheel cover



Pos	Teil-Nummer Part-Number	Stück Piece	Beschreibung Description	Benennung	Designation
18	26 722 03 50 0	4	88,9/71,3/37,5	Buchse	Bushing
	26 722 04 50 0	4	88,9/71,3/83,5		
19	25 722 02 92 0	2	119 mm - 210 mm 1)	Aufhängebolzen	Suspension bolt
	25 722 03 92 0	2	215 mm - 300 mm 1)		
20	25 722 00 52 0	60	3 mm	Scheibe	Disc
21	25 722 01 52 0	4	7,5 mm	Scheibe	Disc
23	504 961 0	2	10x40	Spannstift	Dowel pin
26	506 039 0	4	M48x1,5	Kronenmutter	Castellated nut
27	504 126 0	4	8x80	Splint	Cotter pin
30	26 722 00 26 0	1	KEH-A 160	Kopfrägerprofil	End carriage profile
32	23 722 01 85 0	2		Pufferbefestigung	Buffer fastening
33	500 303 0	4	M12x40	Skt-Schraube	Hexagon head cap screw
34	506 550 0	4	M12	Skt-Mutter	Hexanal nut
35	577 416 0	2		Kranpuffer	Buffer
40	502 006 0	4	M24x85	Skt-Schraube	Hexagon head cap screw
41	507 078 0	12	21	Scheibe	Disc
42	26 722 00 52 0	4	48/25/10	Scheibe	Disc
43	501 113 0	4	M24	Skt-Mutter	Nut
45	23 720 00 80 0	1		Typenschild	Type plate
46	507 841 0	2	3x5	Blindniet	Blind rivet
47	23 722 01 42 0	1	(Pos.46)	Hinweisschild	Information sign
48	23 722 00 42 0	2		Hinweisschild	Information sign

1) Flanschbreite

1) Flange width



**Originalteile**  
**Original parts**  
**KEH-B080**

Austausch und Reparaturen nur von geschultem Personal ausführen lassen.

Replacement and repairs may only be carried out by trained personnel.

Die Angaben in der Spalte "Benennung" dienen nur internen Vorgängen.

The information in the column "Designation" is only for internal use.

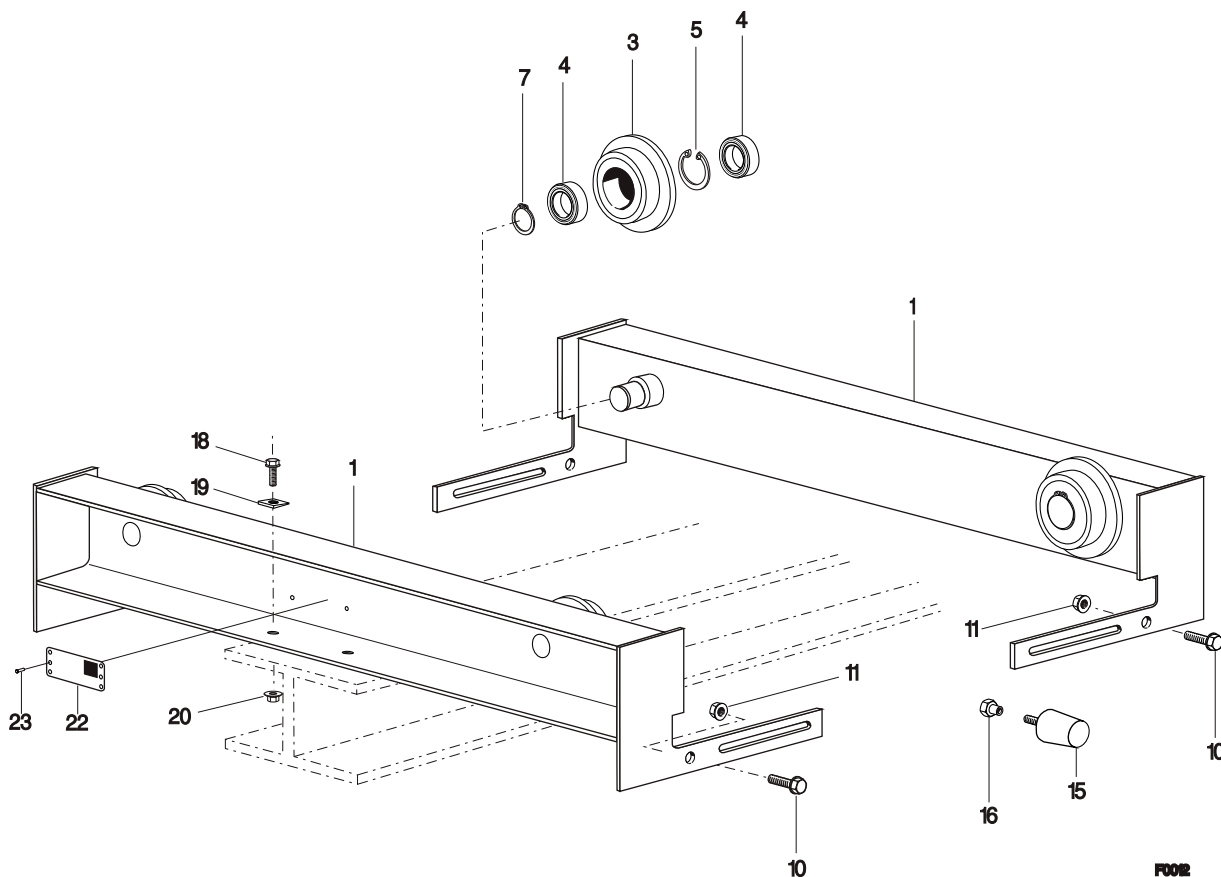

Pos	Teil-Nummer Part-Number	Stück Piece	Beschreibung Description	Benennung	Designation
1	23 720 02 25 0	2		Fahrwerkschild	Carriage side plate
3	03 250 02 41 0	4	B 80	Laufrolle	Wheel
4	560 950 0	8	6004-2RS	Rillenkugellager	Grooved ball bearing
5	506 105 0	4	42x1,75	Sicherungsring	Locking ring
7	506 095 0	4	20x1,2	Sicherungsring	Locking ring
10	501 112 0	4	M12x40	Sicherungsschraube	Locking screw
11	507 840 0	4	M12	Sicherungsmutter	Locking nut
15	577 985 0	2	40No17 220	Gummipuffer	Rubber buffer
16	23 722 00 91 0	2		Mutter	Nut
18	501 112 0	4	M12x40	Sicherungsschraube	Locking screw
19	506 050 0	4	13	U-Scheibe	U-Disc
20	507 840 0	4	M12	Sicherungsmutter	Locking nut
22	23 720 00 80 0	1		Typenschild	Type plate
23	507 831 0	2	3x5	Blindniet	Blind rivet





Austausch und Reparaturen nur von geschultem Personal ausführen lassen.  
Die Angaben in der Spalte "Benennung" dienen nur internen Vorgängen.

Replacement and repairs may only be carried out by trained personnel.  
The information in the column "Designation" is only for internal use.

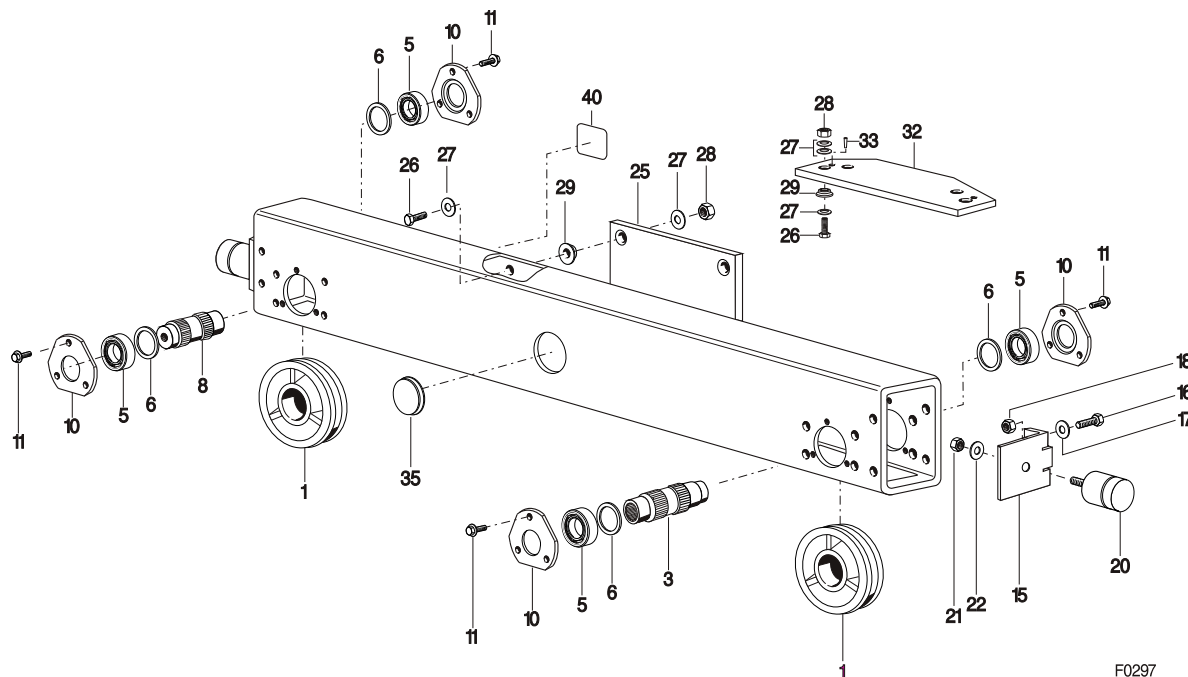

F0297

Pos	Teil-Nummer Part-Number	Stück Piece	Beschreibung Description	Benennung	Designation
1	24 254 10 01 0	2	D 125 mm *) 40 mm	Lauftrad	Travelling wheel
	24 254 11 01 0	2	D 125 mm *) 50 mm		
3	24 254 12 14 0	1		Laufradwelle	Travelling wheel shaft
5	560 005 0	4	6208-2Z DIN 625	Rillenkugellager	Grooved ball bearing
6	33 245 00 03 0	4	60/41/2	Scheibe	Disc
8	24 254 11 17 0	1		Laufradachse	Axle
10	25 712 04 58 0	4		Lagerdeckel	Bearing cover
11	501 104 0	12	M10x20-10	Sicherungsschraube	Locking screw
15	25 710 20 23 0	2		Pufferplatte	Buffer plate
16	500 334 0	4	M12x45 DIN 933	Skt-Schraube	Hexagon head cap screw
17	507 104 0	4	SKM 12	Sperrkantscheibe	Nut
18	506 828 0	4	M12	Setzmutter	Disc
20	577 416 0	2		Kranpuffer	Buffer
21	506 550 0	2	M12 DIN 934	Skt-Mutter	Hexagonal nut
22	507 104 0	2	SKM 12	Sperrkantscheibe	Disc
25	25 710 00 70 0	1		Tragplatte	Supporting plate
26	501 048 0	4	M20x75 DIN 6914	Skt-Schraube	Hexagon head cap screw
27	507 064 0	12	21	Scheibe	Disc
28	501 070 0	4	M20 DIN 6915	Skt-Mutter	Hexagonal nut
29	25 712 01 50 0	4		Buchse	Bushing
32	25 710 04 70 0	1		Tragplatte	Supporting plate
33	504 208 0	2	12x60 DIN 7978	Kegelstift	Pin
35	25 712 00 58 0	1	D 100	Deckel	Cover
40	25 712 00 46 0	1		Klebeschild	Sign

\*) Schienenbreite

\*) Rail width



**Originalteile**  
**Original parts**  
**KEL/KZL-S160**

Austausch und Reparaturen nur von geschultem Personal ausführen lassen.

Replacement and repairs may only be carried out by trained personnel.

Die Angaben in der Spalte "Benennung" dienen nur internen Vorgängen.

The information in the column "Designation" is only for internal use.

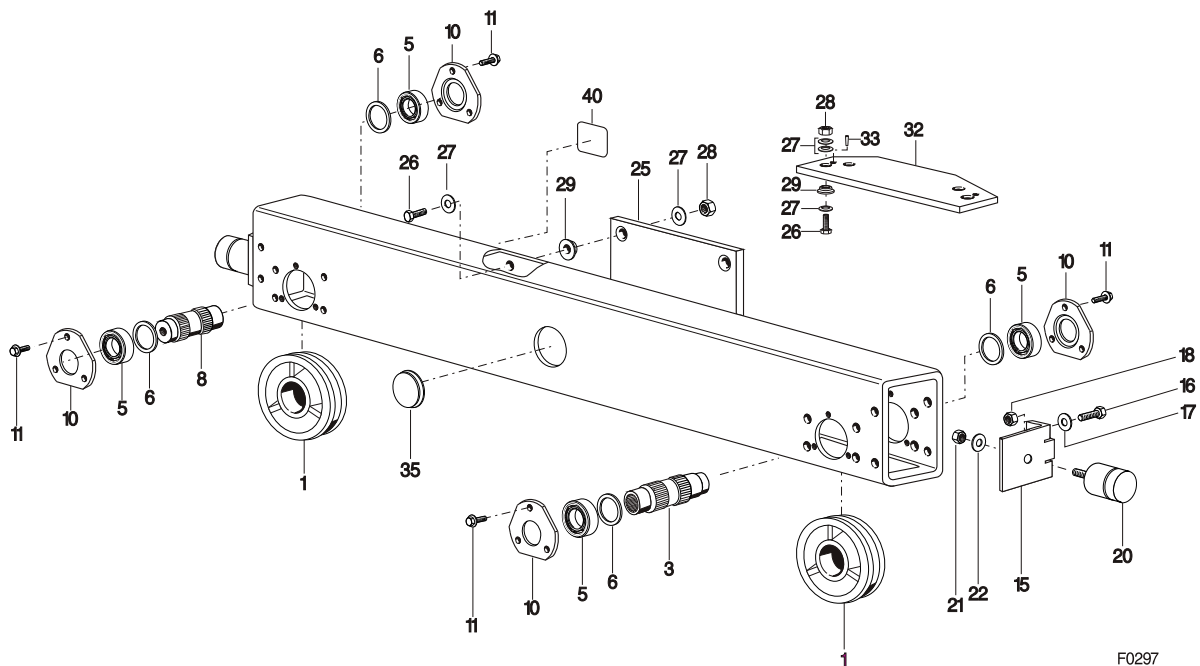

F0297

Pos	Teil-Nummer Part-Number	Stück Piece	Beschreibung Description		Benennung	Designation
1	24 254 20 01 0	2	D 160 mm	*) 40 mm	Laufgrad	Travelling wheel
	24 254 21 01 0	2	D 160 mm	*) 50 mm		
3	24 254 24 14 0	1	SF 25		Laufgradwelle	Travelling wheel shaft
5	560 979 0	4	6211-2Z	DIN 625	Rillenkugellager	Grooved ball bearing
6	26 712 00 51 0	4	70/55,5/10		Distanzring	Supporting ring
8	24 254 21 17 0	1			Laufgradachse	Axle
10	26 712 03 58 0	4			Lagerdeckel	Bearing cover
11	501 104 0	12	M10x20-10		Sicherungsschraube	Locking screw
15	25 712 01 83 0	2			Pufferplatte	Buffer plate
16	500 334 0	4	M12x45	DIN 933	Skf-Schraube	Hexagon head cap screw
17	507 104 0	4	SKM 12		Sperrkantscheibe	Disc
20	577 416 0	2			Kranpuffer	Buffer
21	506 550 0	2	M12	DIN 934	Skf-Mutter	Hexagonal nut
22	507 104 0	2	SKM 12		Sperrkantscheibe	Disc
25	26 710 00 70 0	1	KEL-S	(Pos.29)	Tragplatte	Supporting plate
	26 710 03 70 0	2	KZL-S	(Pos.29)		
26	501 048 0		M20x75	x)	Skf-Schraube	Hexagon head cap screw
27	507 064 0		21	x)	Scheibe	Disc
28	501 070 0		M20	x)	Skf-Mutter	Hexagonal nut
29	25 712 01 50 0			x)	Buchse	Bushing
32	26 710 06 70 0	1			Tragplatte	Supporting plate
33	504 208 0	2	12x60	DIN 7978	Kegelstift	Pin
35	25 712 00 58 0		D 100	x)	Deckel	Cover
43	25 712 00 46 0	1			Klebeschild	Sign

\*) Schienenbreite  
x) Stückzahl nach Bedarf

\*) Rail width  
x) Quantity as required



Austausch und Reparaturen nur von geschultem Personal ausführen lassen.

Replacement and repairs may only be carried out by trained personnel.

Die Angaben in der Spalte "Benennung" dienen nur internen Vorgängen.

The information in the column "Designation" is only for internal use.

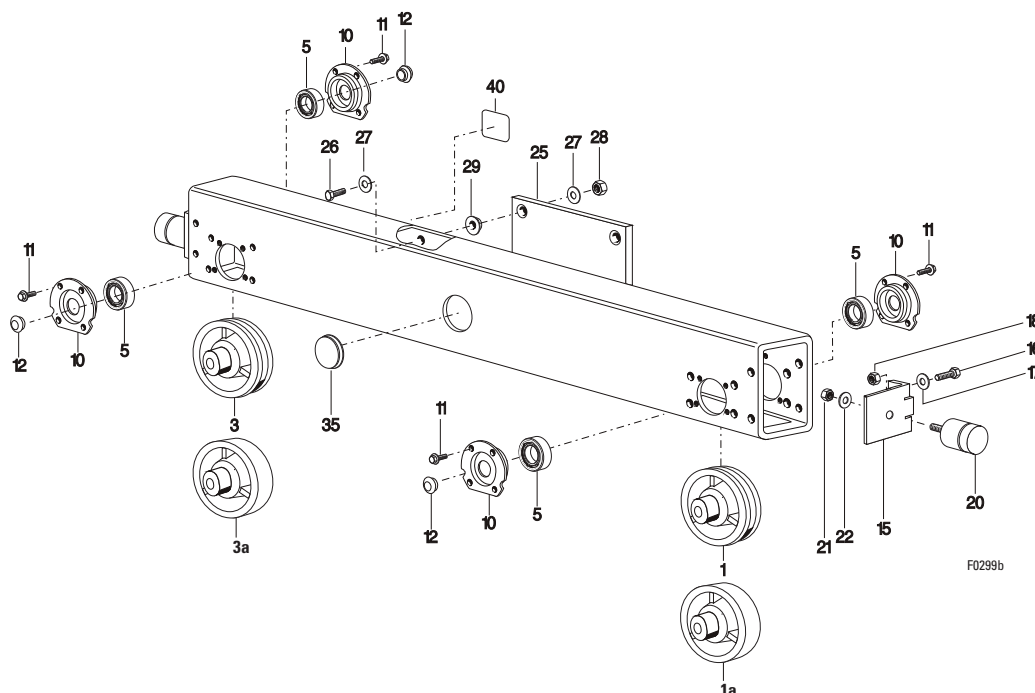

Pos	Teil-Nummer Part-Number	Stück Piece	Beschreibung Description	Benennung	Designation				
1	07 257 04 01 0	1	D 200 mm *) 40 mm **)	Laufрад	Travelling wheel				
	07 257 05 01 0	1	D 200 mm *) 50 mm **)						
	07 257 06 01 0	1	D 200 mm *) 60 mm **)						
	07 257 08 01 0	1	D 200 mm *)						
3	07 257 00 05 0	1	D 200 mm 40 mm **)	Laufрад	Travelling wheel				
	07 257 01 05 0	1	D 200 mm 50 mm **)						
	07 257 02 05 0	1	D 200 mm 60 mm **)						
	07 257 03 05 0	1	D 200 mm						
5	560 040 0	4	6311-2Z	Rillenkugellager	Grooved ball bearing				
	27 712 03 58 0	4				Lagerflansch	Flange bearing		
	501 117 0	16	M10x30					Sicherungsschraube	Locking screw
	515 030 0	3							
15	27 712 01 83 0	2		Pufferplatte	Buffer plate				
	500 334 0	4	M12x45			Skt-Schraube	Hexagon head cap screw		
17	507 104 0	4	SKM 12	Sperrkantscheibe	Disc				
	506 828 0	4	M12			Setzmutter	Nut		
20	577 417 0	2		Kranpuffer	Buffer				
	506 550 0	2	M12			Skt-Mutter	Hexagonal nut		
22	507 104 0	2	SKM 12	Sperrkantscheibe	Disc				
	25	27 710 04 70 0	1			KEL-S (Pos.29)	Tragplatte	Supporting plate	
27 710 05 70 0		2	KZL-S 200.....36 (Pos.29)						
27 710 06 70 0		2	KZL-S 200.....56 (Pos.29)						
26	502 966 0	4	M20x80 KEL-S	Skt-Schraube	Hexagon head cap screw				
	501 048 0	8	M20x75 KZL-S						
26.1	502 967 0	4	M20x85						
27	507 064 0	21	x) DIN 6915	Scheibe	Disc				
	501 070 0	M20	x)			Skt-Mutter	Hexagonal nut		
29	25 712 01 50 0		x)	Buchse	Bushing				
	32	27 710 11 70 0	1			(Pos.29)	Tragplatte	Supporting plate	
504 208 0		2	12x60 ISO 8736	Kegelstift	taper pin				
35	27 712 04 58 0		D 150 x)			Deckel	Cover		
40	25 712 00 46 0	1		Klebeschild	Sign				

\*) für Antrieb  
\*\*) Schienenbreite  
x) Stückzahl nach Bedarf

\*) for drive  
\*\*) Rail width  
x) Quantity as required

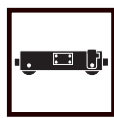

**Originalteile**  
**Original parts**  
**KEL/KZL-S315**

Austausch und Reparaturen nur von geschultem Personal ausführen lassen.

Replacement and repairs may only be carried out by trained personnel.

Die Angaben in der Spalte "Benennung" dienen nur internen Vorgängen.

The information in the column "Designation" is only for internal use.

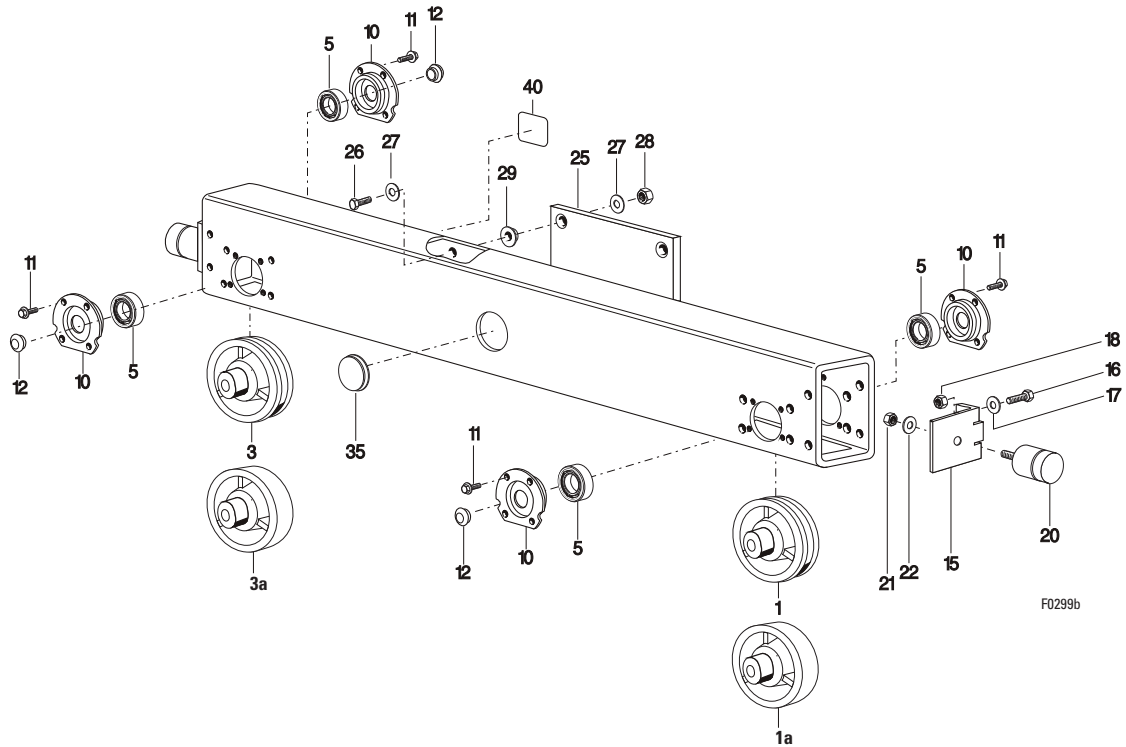

Pos	Teil-Nummer Part-Number	Stück Piece	Beschreibung Description	Benennung	Designation
1	09 257 06 01 0	1	D 315 mm *) 40 mm **)	LaufRad	Travelling wheel
	09 257 07 01 0	1	D 315 mm *) 50 mm **)		
	09 257 08 01 0	1	D 315 mm *) 60 mm **)		
1a	09 257 09 01 0	1	D315 mm *)		
3	09 257 00 05 0	1	D 315 mm 40 mm **)	LaufRad	Travelling wheel
	09 257 01 05 0	1	D 315 mm 50 mm **)		
	09 257 02 05 0	1	D 315 mm 60 mm **)		
3a	09 257 03 05 0	1	D 315 mm		
5	560 001 0	4	6218-2Z	Rillenkugellager	Grooved ball bearing
10	29 712 04 58 0	4		Lagerflansch	Flange bearing
11	502 980 0	16	M12x30	Sicherungsschraube	Locking screw
12	515 952 0	3		Verschluss	Plug
15	27 712 01 83 0	2		Pufferplatte	Buffer plate
16	500 334 0	4	M12x45	Skt-Schraube	Hexagon head cap screw
17	507 104 0	4	SKM 12	Sperrkantscheibe	Disc
18	506 828 0	4	M12	Setzmutter	Nut
20	577 418 0	2		Kranpuffer	Buffer
21	506 550 0	2	M12	Skt-Mutter	Hexagonal nut
22	507 104 0	2	SKM 12	Sperrkantscheibe	Disc
25	29 710 04 70 0	1	KEL-S (Pos.29)	Tragplatte	Supporting plate
	29 710 05 70 0	2	KZL-S 315.....36 (Pos.29)		
	29 710 06 70 0	2	KZL-S 315.....56 (Pos.29)		
26	502 966 0	4	M20x80 KEL-S	Skt-Schraube	Hexagon head cap screw
	501 048 0	12	M20x75 KZL-S		
27	507 064 0		x)	Scheibe	Disc
28	501 070 0		21 x)	Skt-Mutter	Hexagonal nut
29	25 712 01 50 0		M20 x)	Buchse	Bushing
35	27 712 04 58 0		D 150 x)	Deckel	Cover
40	25 712 00 46 0	1		Klebeschild	Sign

\*) für Antrieb  
\*\*) Schienenbreite  
x) Stückzahl nach Bedarf

\*) for drive  
\*\*) Rail width  
x) Quantity as required



Austausch und Reparaturen nur von geschultem Personal ausführen lassen.

Replacement and repairs may only be carried out by trained personnel.

Die Angaben in der Spalte "Benennung" dienen nur internen Vorgängen.

The information in the column "Designation" is only for internal use.

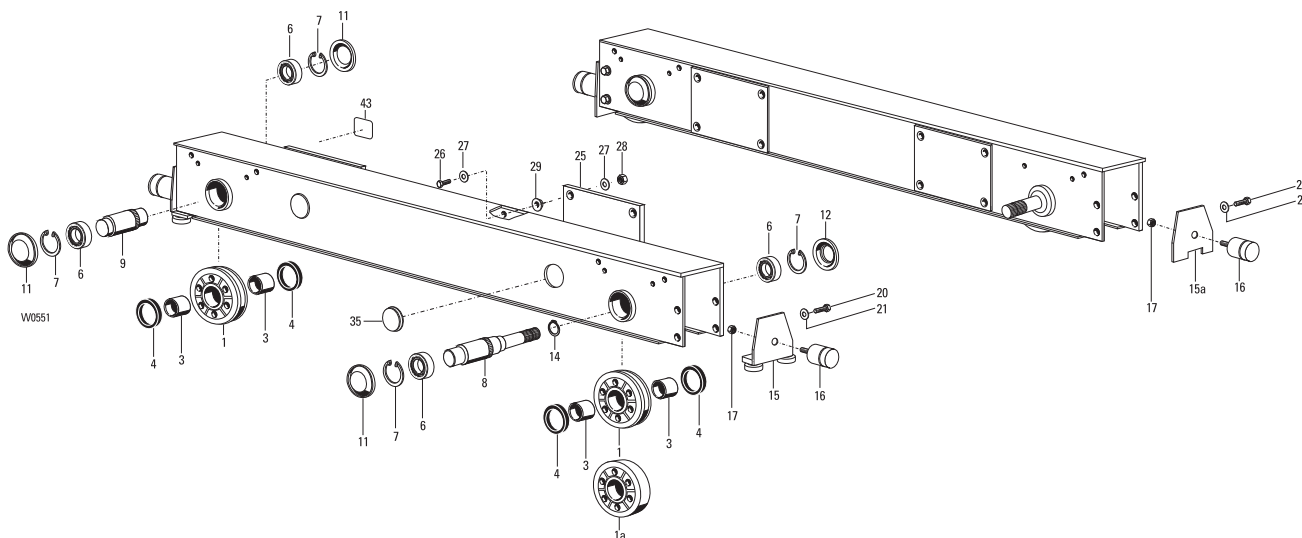

Pos	Teil-Nummer Part-Number	Stück Piece	Beschreibung Description		Benennung	Designation	
1	24 254 62 01 0	2	D 400 mm	*)	50 mm	Laufрад	Travelling wheel
	24 254 63 01 0	2	D 400 mm	*)	60 mm		
	24 254 64 01 0	2	D 400 mm	*)	70 mm		
1a	24 254 60 01 0	2	D 400 mm		Laufрад	Travelling wheel	
3	561 001 0	4			Buchse	Bushing	
4	518 303 0	4			Dichtring	Sealing ring	
6	560 808 0	4	222 18		Pendelrollenlager	Poller bearing	
7	506 922 0	4	160x4		Sicherungsring	Locking ring	
8	24 254 60 14 0	1			Laufradwelle	Travelling wheel shaft	
9	24 254 60 17 0	1			Laufradachse	Axle	
11	29 712 00 58 0	3			Verschlussdeckel	End cap	
12	29 712 01 58 0	1			Verschlussdeckel	End cap	
14	506 916 0	1	65x2,5		Sicherungsring	Locking ring	
15	30 710 00 31 0	2	50 mm	*)	(Pos.16+17)	Führungsrollenträger	Guide roller support
	30 710 01 31 0	2	60 mm	*)	(Pos.16+17)		
	30 710 02 31 0	2	70 mm	*)	(Pos.16+17)		
	30 710 03 31 0	2	100 mm	*)	(Pos.16+17)		
15a	30 710 79 31 0	2	<= 60 mm	*)	(Pos.16+17)	Entgleisungsschutz	Anti-derail device
	30 710 80 31 0	2	> 60 mm <= 100 mm	*)	(Pos.16+17)		
16	577 418 0	2			Kranpuffer	Buffer	
17	506 828 0	2	M12		Setzmutter	Nut	
20	500 919 0	8	M24x60		Skt-Schraube	Hexagon head cap screw	
21	562 000 0	8	24		Spannscheibe	Disc	
25	30 710 00 70 0	2	KZL-C 400.9.31.140		(Pos.29)	Tragplatte	Supporting plate
	30 710 02 70 0	2	KZL-C 400.5.40.140		(Pos.29)		
	30 710 02 70 0	1	KEL-C		(Pos.29)		
	30 710 01 70 0	2	KZL-C 400.....58		(Pos.29)		
26	502 978 0		M30x105	x)	DIN 6914	Skt-Schraube	Hexagon head cap screw
27	507 080 0		31	x)	DIN 6916	Scheibe	Disc
28	501 073 0		M30	x)	DIN 6915	Skt-Mutter	Hexagonal nut
29	30 712 01 50 0			x)		Buchse	Bushing
35	27 712 04 58 0	2			Deckel	Cover	
43	25 712 00 46 0	1			Klebeschild	Sign	

\*) Schienenbreite  
x) Stückzahl nach Bedarf

\*) Rail width  
x) Quantity as required

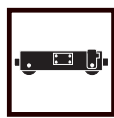

**Originalteile**  
**Original parts**  
**KZL-F500**

Austausch und Reparaturen nur von geschultem Personal ausführen lassen.

Replacement and repairs may only be carried out by trained personnel.

Die Angaben in der Spalte "Benennung" dienen nur internen Vorgängen.

The information in the column "Designation" is only for internal use.

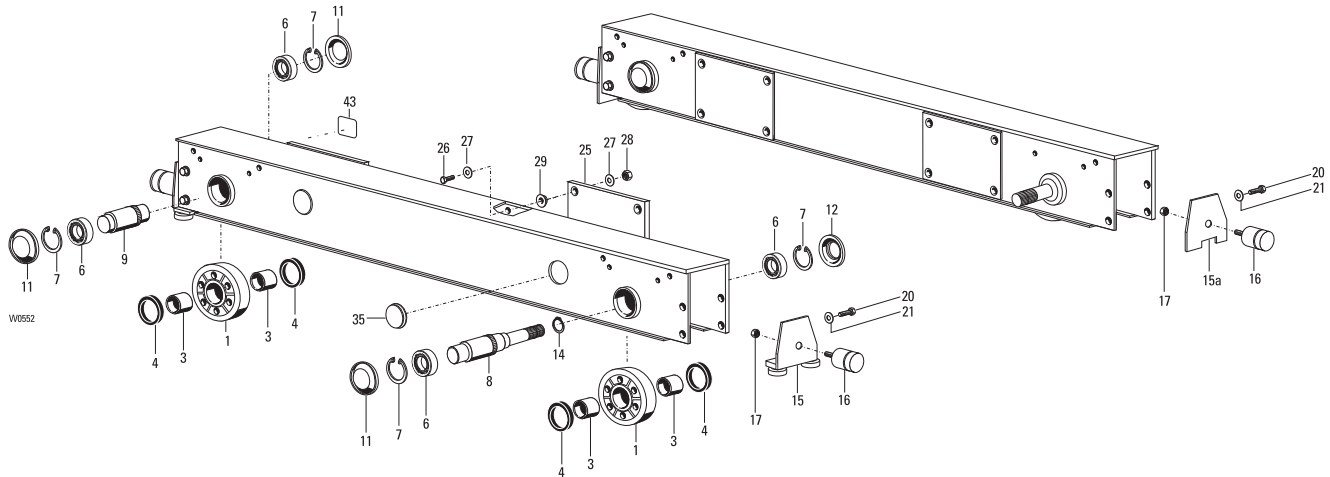

Pos	Teil-Nummer Part-Number	Stück Piece	Beschreibung Description		Benennung	Designation
1	24 254 70 01 0	2	D 500 mm		Laufrad	Travelling wheel
3	561 001 0	4			Buchse	Bushing
4	518 303 0	4			Dichtring	Sealing ring
6	560 808 0	4	222 18		Pendelrollenlager	Poller bearing
7	506 922 0	4	160x4	DIN 472	Sicherungsring	Locking ring
8	24 254 60 14 0	1			Laufradwelle	Travelling wheel shaft
9	24 254 60 17 0	1			Laufradachse	Axle
11	29 712 00 58 0	3			Verschußdeckel	End cap
12	29 712 01 58 0	1			Verschußdeckel	End cap
14	506 916 0	1	65x2,5	DIN 471	Sicherungsring	Locking ring
15	31 710 00 31 0	2	50 mm	*) (Pos.16+17)	Führungsrollenträger	Guide roller support
	31 710 01 31 0	2	60 mm	*) (Pos.16+17)		
	31 710 02 31 0	2	70 mm	*) (Pos.16+17)		
	31 710 03 31 0	2	100 mm	*) (Pos.16+17)		
15a	31 710 79 31 0	2	<=60 mm	*) (Pos.16+17)	Entgleisungsschutz	Anti-derail device
	31 710 80 31 0	2	>60 mm <= 100 mm	*) (Pos.19+17)		
16	577 419 0	2			Kranpuffer	Buffer
17	506 828 0	2	M12		Setzmutter	Nut
20	500 919 0	8	M24x60	DIN 933	Skt-Schraube	Hexagon head cap screw
21	562 000 0	8	24		Spannscheibe	Disc
25	31 710 00 70 0	2	KZL-F 500.....140	(Pos.29)	Tragplatte	Supporting plate
	31 710 01 70 0	2	KZL-F 500.....58	(Pos.29)		
	31 710 02 70 0	2	KZL-F 500.....578	(Pos.29)		
26	502 978 0	12	M30x105	DIN 6914	Skt-Schraube	Hexagon head cap screw
27	507 080 0	24	31	DIN 6916	Scheibe	Disc
28	501 073 0	12	M30	DIN 6915	Skt-Mutter	Hexagonal nut
29	30 712 01 50 0	8			Buchse	Bushing
35	27 712 04 58 0	2			Deckel	Cover
43	25 712 00 46 0	1			Klebeschild	Sign

\*) Schienenbreite

\*) Rail width



Austausch und Reparaturen nur von geschultem Personal ausführen lassen.

Replacement and repairs may only be carried out by trained personnel.

Die Angaben in der Spalte "Benennung" dienen nur internen Vorgängen.

The information in the column "Designation" is only for internal use.

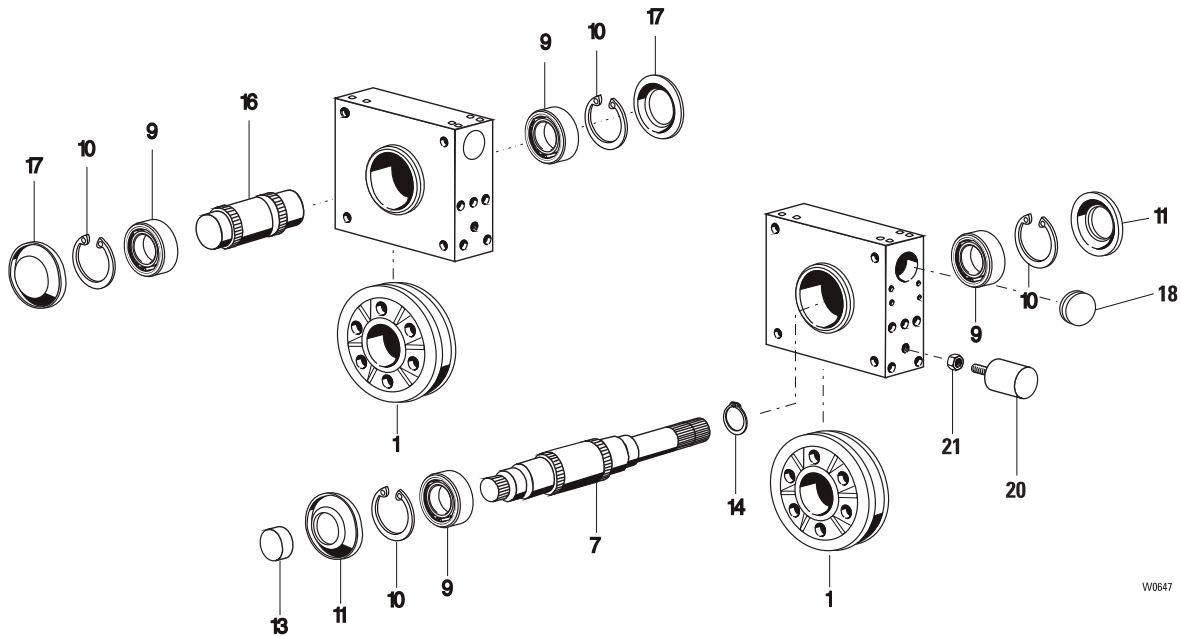

W0647

Pos	Teil-Nummer Part-Number	Stück Piece	Beschreibung Description	Benennung	Designation
1	24 254 50 01 0	4	D315 1) 40 mm	Laufrad	Wheel
	24 254 51 01 0	4	D315 1) 50 mm		
	24 254 52 01 0	4	D315 1) 60 mm		
7	24 254 51 14 0	2		Laufradwelle	Axle
9	560 001 0	8	6218-2Z	Rillenkugellager	Grooved ball bearing
10	506 922 0	8	160x4	Sicherungsring	Locking ring
11	29 712 01 58 0	4		Verschlußdeckel	Cover
13	518 022 0	2		Schutzkappe	Protective cap
14	506 916 0	2	65x2,5	Sicherungsring	Locking ring
16	24 254 50 17 0	2		Laufradachse	Axle
17	29 712 00 58 0	4		Verschlußdeckel	Cover
18	25 712 00 58 0	4		Deckel	over
20	577 416 0		x)	Cellasto-Kranpuffer	Buffer
21	506 550 0		x)	Skt-Mutter	Hexagonal nut

1) Schienenbreite  
x) Stückzahl nach Bedarf

1) Rail width  
x) Quantity as required



**Originalteile**  
**Original parts**  
**FE-A 400**

Austausch und Reparaturen nur von geschultem Personal ausführen lassen.

Replacement and repairs may only be carried out by trained personnel.

Die Angaben in der Spalte "Benennung" dienen nur internen Vorgängen.

The information in the column "Designation" is only for internal use.

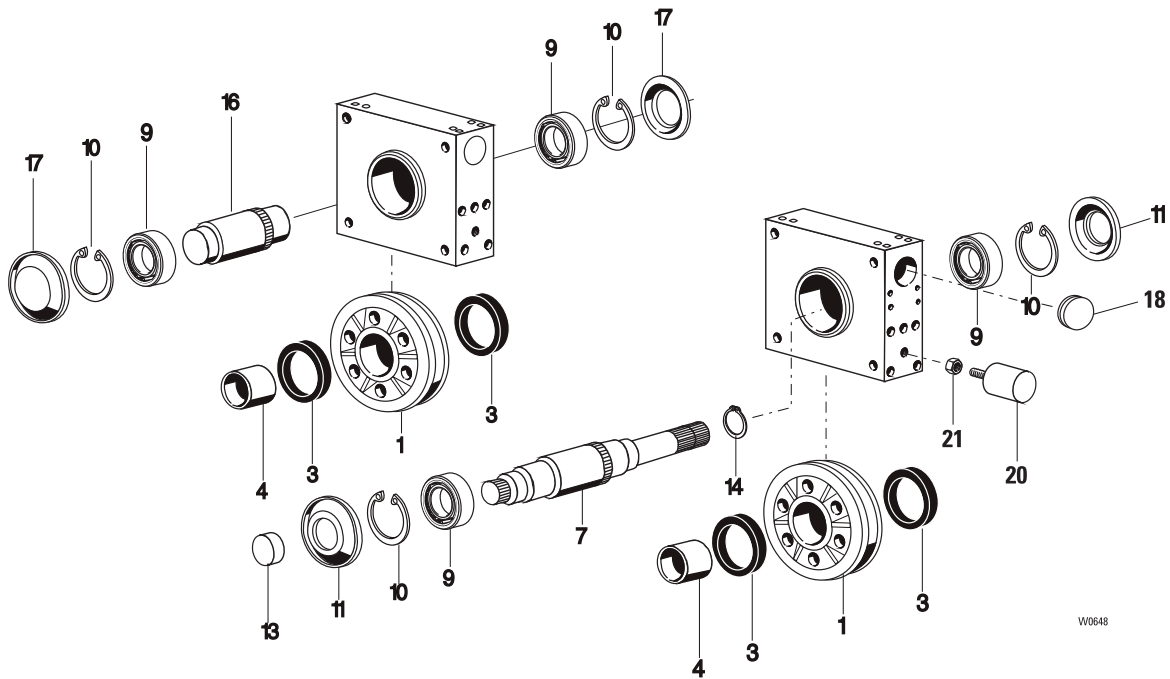

W0648

Pos	Teil-Nummer Part-Number	Stück Piece	Beschreibung Description	Benennung	Designation
1	24 254 62 01 0	4	D400 1) 50 mm	LaufRad	Wheel
	24 254 63 01 0	4	D400 1) 60 mm		
	24 254 64 01 0	4	D400 1) 70 mm		
3	518 303 0	8		Dichtring	Sealing ring
4	561 001 0	4		Buchse	Bushing
7	24 254 61 14 0	2		LaufRadwelle	Axle
9	560 808 0	8	222 18	Pendelrollenlager	Roller bearing
10	506 922 0	8	160x4	Sicherungsring	Locking ring
11	29 712 01 58 0	4		Verschlussdeckel	Cover
13	518 022 0	2		Schutzkappe	Protective cap
14	506 916 0	2	65x2,5	Sicherungsring	Locking ring
16	24 254 60 17 0	2		LaufRadachse	Axle
17	29 712 00 58 0	4		Verschlussdeckel	Cover
18	25 712 00 58 0	4		Deckel	Cover
20	577 416 0		x)	Cellasto-Kranpuffer	Buffer
21	506 550 0		x)	Skt-Mutter	Hexagonal nut

1) Schienenbreite

x) Stückzahl nach Bedarf

1) Rail width

x) Quantity as required





**A05S ex**

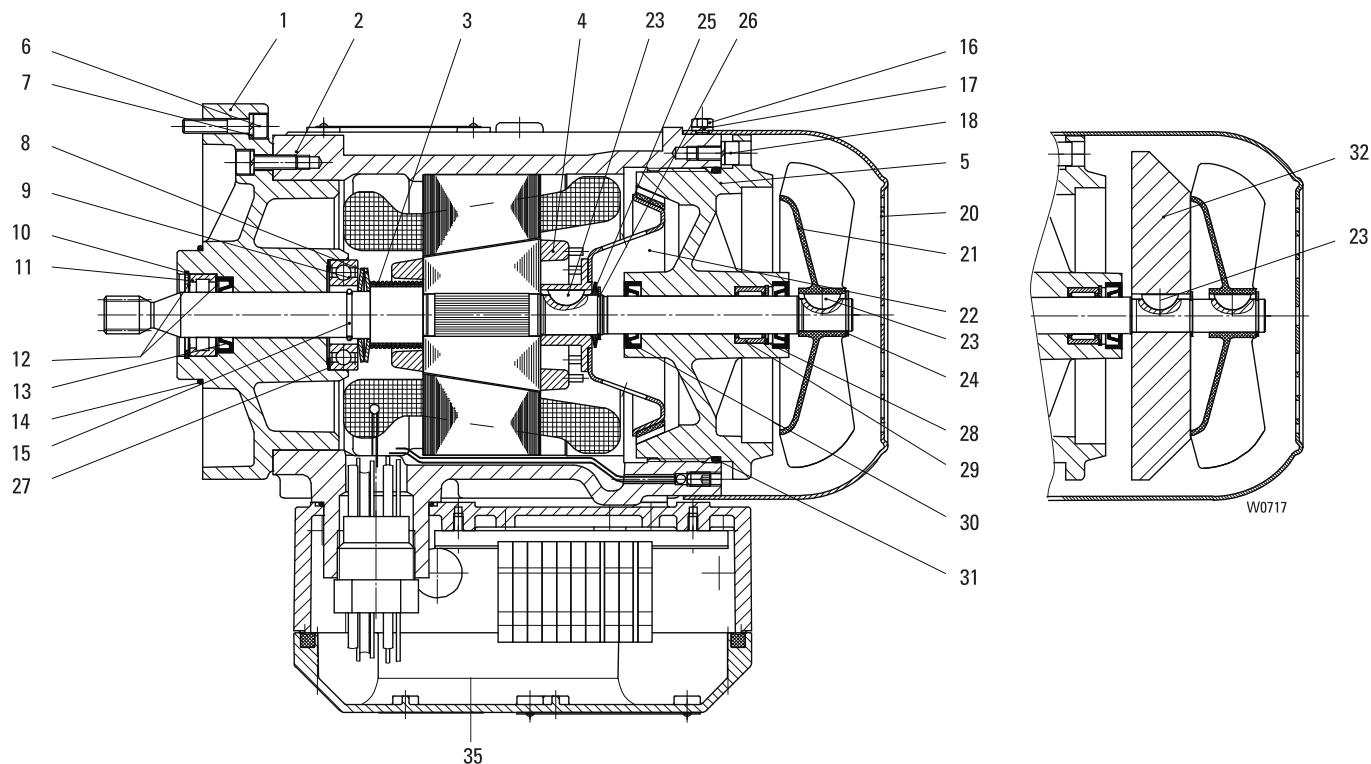

Pos	Teil-Nummer Part-Number	Stück Piece	Beschreibung Description	Benennung Designation	Designation
	35 330 58 11 0	1	2/8A05S IIB 1) (Pos.1-35)	Motor	Motor
	35 330 59 11 0	1	2/8A05S IIC 1) (Pos.1-35)		
1	35 331 23 03 0	1	IIB	Motorflansch	Motor flange
	35 331 24 03 0	1	IIC		
2	35 330 77 14 9	1		Stator	Stator
3	33 331 20 94 0	1	1)	Druckfeder	Pressure spring
4	35 330 27 13 0	1		Rotor	Rotor
5	35 330 05 37 0	1	IIB (Pos.28-31)	Motordeckel	Motor cover
	35 330 04 37 0	1	IIC (Pos.28-31)		
	35 330 06 37 0	1	2) (Pos.28-31)		
6	500 976 0	8	M6X30 ISO 4762	Zyl.-Schraube	Socket head cap screw
7	506 335 0	8	6 DIN 7980	Federring	Spring washer
8	562 901 0	2	40x20,4x2,65x1,5	Tellerfeder	Cup spring
9	560 951 0	1	6005-2RS	Rillenkugellager	Grooved ball bearing
10	506 261 0	1	35x1,5	Sicherungsring	Circlip
11	506 843 0	1	RNU202E	Zyl.-Rollenlager	Roller bearing
12	506 889 0	2	25x35x0,3	Passscheibe	Adjusting washer
13	561 893 0	1	A19x32x7	Wellendichtring	Shaft seal
14	515 946 0	1	55x2	Runddichtring	Round sealing ring
15	507 836 0	1	A20	Spreng ring	Spring ring
16	500 419 0	4	M5x8	Skt-Schraube	Hexagon head cap screw
17	506 900 0	4	5	Federring	Spring washer
18	500 230 0	4	M6x12	Zyl.-Schraube	Socket head cap screw
20	35 331 23 40 0	1		Lüfterhaube	Fan cover
21	576 033 0	1	V71 R/14	Lüfterrad	Fan wheel

1) Bitte Betriebsspannung und Frequenz angeben.  
2) hartverchromt

1) Please state operating voltage and frequency.  
2) Hard chrome plated



**Originalteile**  
**Original parts**  
**FU-B ex**

**A05S ex**

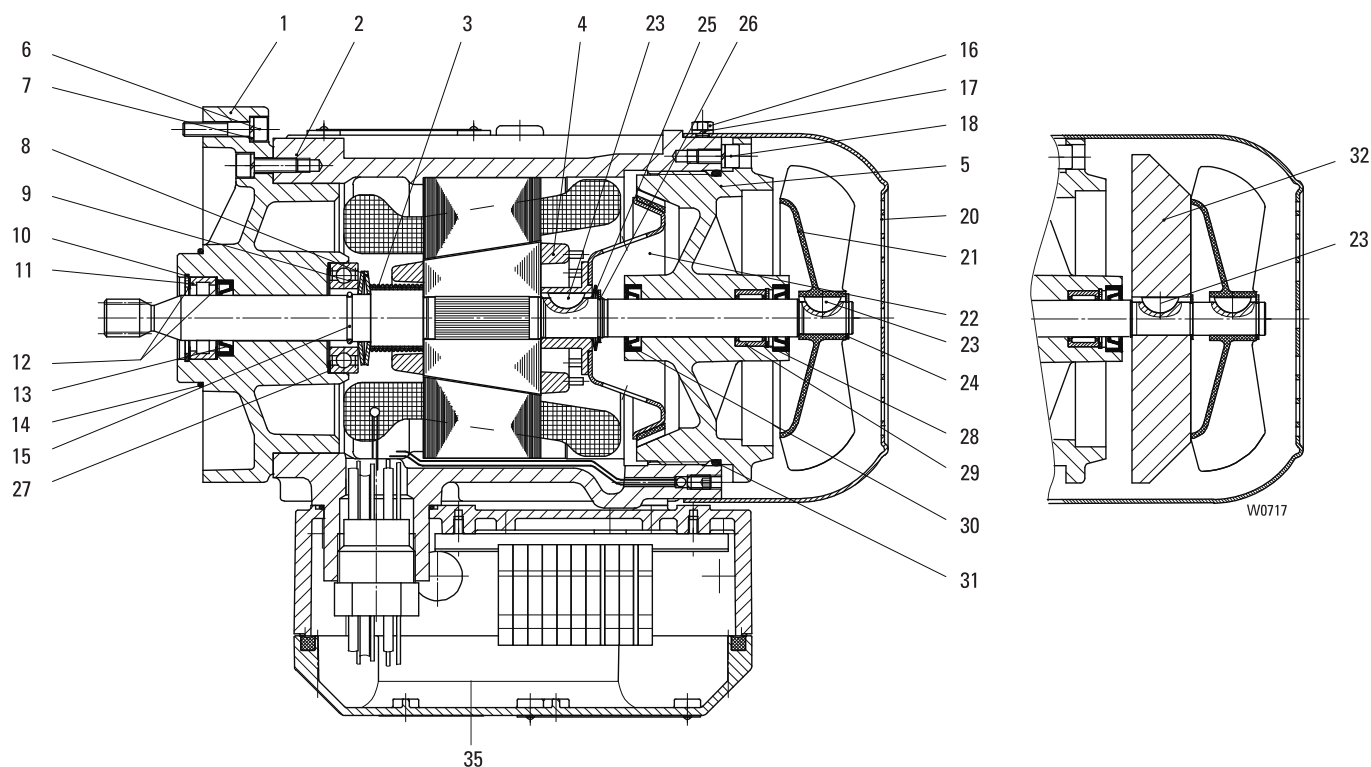

Pos	Teil-Nummer Part-Number	Stück Piece	Beschreibung Description	Benennung	Designation
22	35 330 20 18 0	1		Bremsscheibe	Brake disc
23	537 936 0	2	5x6,5 DIN 6888	Scheibenfeder	Woodruf key
24	506 890 0	1	14x1 DIN 471	Sicherungsring	Circlip
25	562 949 0	2	27,7x17,3x1,45	Tellerfeder	Cup spring
26	506 386 0	1	17x1 DIN 471	Sicherungsring	Circlip
27	507 837 0	1	37x47x0,3 DIN 988	Passscheibe	Ajusting washer
28	... ..	1	M8x40 ISO 4762	Zyl-Schraube	Socket head cap screw
29	... ..	1	RNA 4901 DIN 617	Nadellager	Needle roller bearing
30	... ..	2	AS 16x28x7 NB	Wellendichtring	Shaft seal
31	... ..	1	115x3 NB 70	Runddichtring	Round sealing ring
35	02 220 20 02 0	1		Anschlusskasten	Terminal box

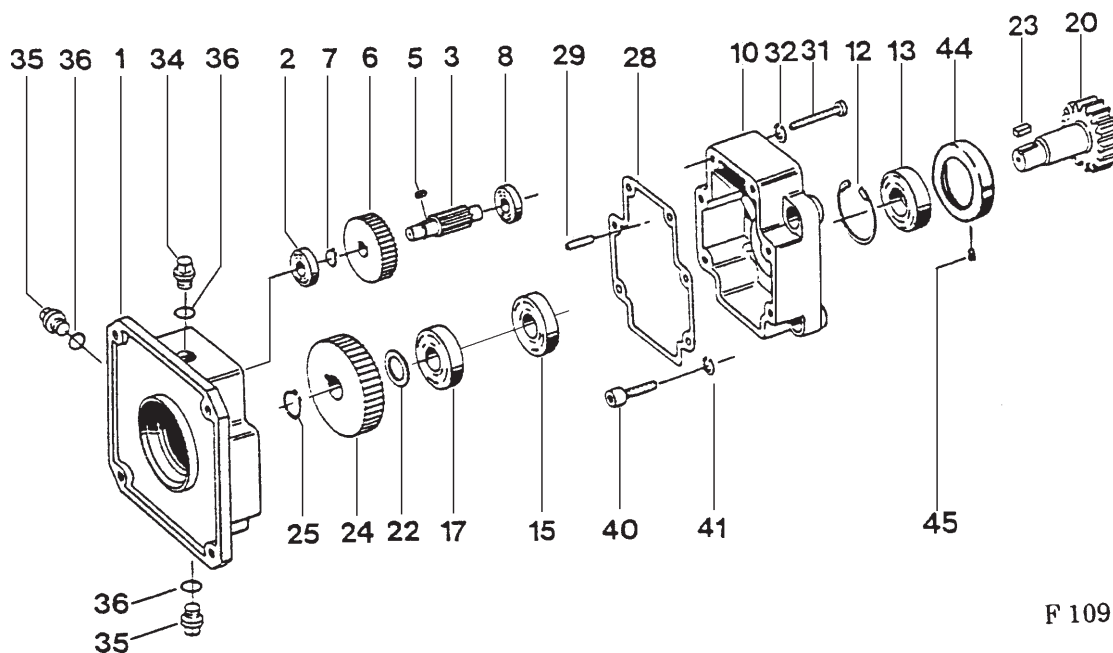

F 1091

Pos	Teil-Nummer Part-Number	Stück Piece	Beschreibung Description	Benennung	Designation
	51 250 53 36 0	1	FU-B 11 .. 11 (Pos.1-41)	Getriebe	Gear
	51 250 62 36 0	1	FU-B 11 .. 12		
	51 250 54 36 0	1	FU-B 11 .. 13		
	51 250 55 36 0	1	FU-B 11 .. 15		
	51 250 56 36 0	1	FU-B 11 .. 19		
	51 250 57 36 0	1	FU-B 11 .. 22		
	51 250 58 36 0	1	FU-B 11 .. 26		
	51 250 59 36 0	1	FU-B 11 .. 31		
	51 250 60 36 0	1	FU-B 11 .. 35		
	51 250 61 36 0	1	FU-B 11 .. 39		
	51 250 63 36 0	1	FU-B 12 .. 11 (Pos.1-41)	Getriebe	Gear
	51 250 72 36 0	1	FU-B 12 .. 12		
	51 250 64 36 0	1	FU-B 12 .. 13		
	51 250 65 36 0	1	FU-B 12 .. 15		
	51 250 66 36 0	1	FU-B 12 .. 19		
	51 250 67 36 0	1	FU-B 12 .. 22		
	51 250 68 36 0	1	FU-B 12 .. 26		
	51 250 69 36 0	1	FU-B 12 .. 31		
	51 250 70 36 0	1	FU-B 12 .. 35		
	51 250 71 36 0	1	FU-B 12 .. 39		
	51 250 15 37 0	1	FU-B 18 .. 12 (Pos.1-45)	Getriebe	Gear
	51 250 13 37 0	1	FU-B 18 .. 15		
	51 250 14 37 0	1	FU-B 18 .. 22		



**Originalteile**  
**Original parts**  
**FU-B ex**

Pos	Teil-Nummer Part-Number	Stück Piece	Beschreibung Description		Benennung	Designation
1	51 253 00 01 0	1			Getriebegehäuse	Gear box
2	560 029 0	1	6000-2RS	DIN 625	Rillenkugellager	Grooved ball bearing
3	51 253 00 19 0	1	Z=11	FU-B 1 ... 11	Ritzelwelle	Pinion
	51 253 10 19 0	1	Z=12	FU-B 1 ... 12		
	51 253 01 19 0	1	Z=13	FU-B 1 ... 13		
	51 253 02 19 0	1	Z=15	FU-B 1 ... 15		
	51 253 03 19 0	1	Z=19	FU-B 1 ... 19		
	51 253 04 19 0	1	Z=22	FU-B 1 ... 22		
	51 253 05 19 0	1	Z=26	FU-B 1 ... 26		
	51 253 06 19 0	1	Z=31	FU-B 1 ... 31		
	51 253 07 19 0	1	Z=35	FU-B 1 ... 35		
	51 253 08 19 0	1	Z=39	FU-B 1 ... 39		
5	537 964 0	1	B4x4x12	DIN 6885	Paßfeder	Feather key
6	51 253 12 11 0	1	Z=57		Zahnrad	Toothed wheel
7	507 029 0	1	S10x16x1,2	DIN 988	Stützscheibe	Spacer ring
8	560 029 0	1	6000-2RS	DIN 625	Rillenkugellager	Grooved ball bearing
10	51 253 01 02 0	1			Getriebedeckel	Gear cap
12	506 105 0	1	42x1,75	DIN 472	Sicherungsring	Locking ring
13	560 950 0	1	6004-2RS	DIN 625	Rillenkugellager	Grooved ball bearing
15	561 869 0	1	A20x42x7	DIN 3760	Wellendichtring	Shaft seal
17	560 950 0	1	6004-2RS	DIN 625	Rillenkugellager	Grooved ball bearing
20	41 253 00 22 0	1	Z=17	FU-B 11	Abtriebsritzel	Drive shaft
	51 253 00 22 0	1	Z=11	FU-B 12		
	51 253 02 22 0	1	Z=19	FU-B 18		
22	507 857 0	1	18x25x1	DIN 988	Paßscheibe	Adjusting washer
23	537 967 0	1	6x6x14	DIN 6885	Paßfeder	Feather key
24	51 253 01 11 0	1	Z=68	FU-B 1 ... 11	Zahnrad	Toothed wheel
	51 253 13 11 0	1	Z=87	FU-B 1 ... 12		
	51 253 02 11 0	1	Z=66	FU-B 1 ... 13		
	51 253 03 11 0	1	Z=64	FU-B 1 ... 15		
	51 253 04 11 0	1	Z=60	FU-B 1 ... 19		
	51 253 05 11 0	1	Z=57	FU-B 1 ... 22		
	51 253 06 11 0	1	Z=53	FU-B 1 ... 26		
	51 253 07 11 0	1	Z=48	FU-B 1 ... 31		
	51 253 08 11 0	1	Z=44	FU-B 1 ... 35		
	51 253 09 11 0	1	Z=40	FU-B 1 ... 39		
25	506 948 0	1	18x1,2	DIN 471	Sicherungsring	Locking ring
28	51 253 00 95 0	1			Dichtung	Seal
29	504 120 0	2	6m6x18	DIN 7	Zyl-Stift	Dowel pin
31	500 390 0	4	M6x45	DIN 912-8.8	Zyl-Schraube	Socket head cap screw
32	506 335 0	4	6	DIN 7980	Federring	Spring washer
34	51 253 00 90 0	1			Entlüftungsschraube	Vent screw
35	503 965 0	2	M10x1	DIN 910-5.8	Verschlussschraube	Screw plug
36	515 996 0	3	C10x13,5	DIN 7603	Dichtring	Sealing ring
40	500 234 0	4	M8x25	DIN 912-8.8	Zyl-Schraube	Socket head cap screw
41	506 459 0	4	8	DIN 7980	Federring	Spring washer
44	51 253 00 51 0	1			Zentrierring	Eccentric ring
45	503 907 0	1	M6x5	DIN 551-5.8	Gewindestift	Threaded pin

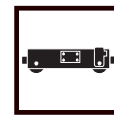

**A05 ex**

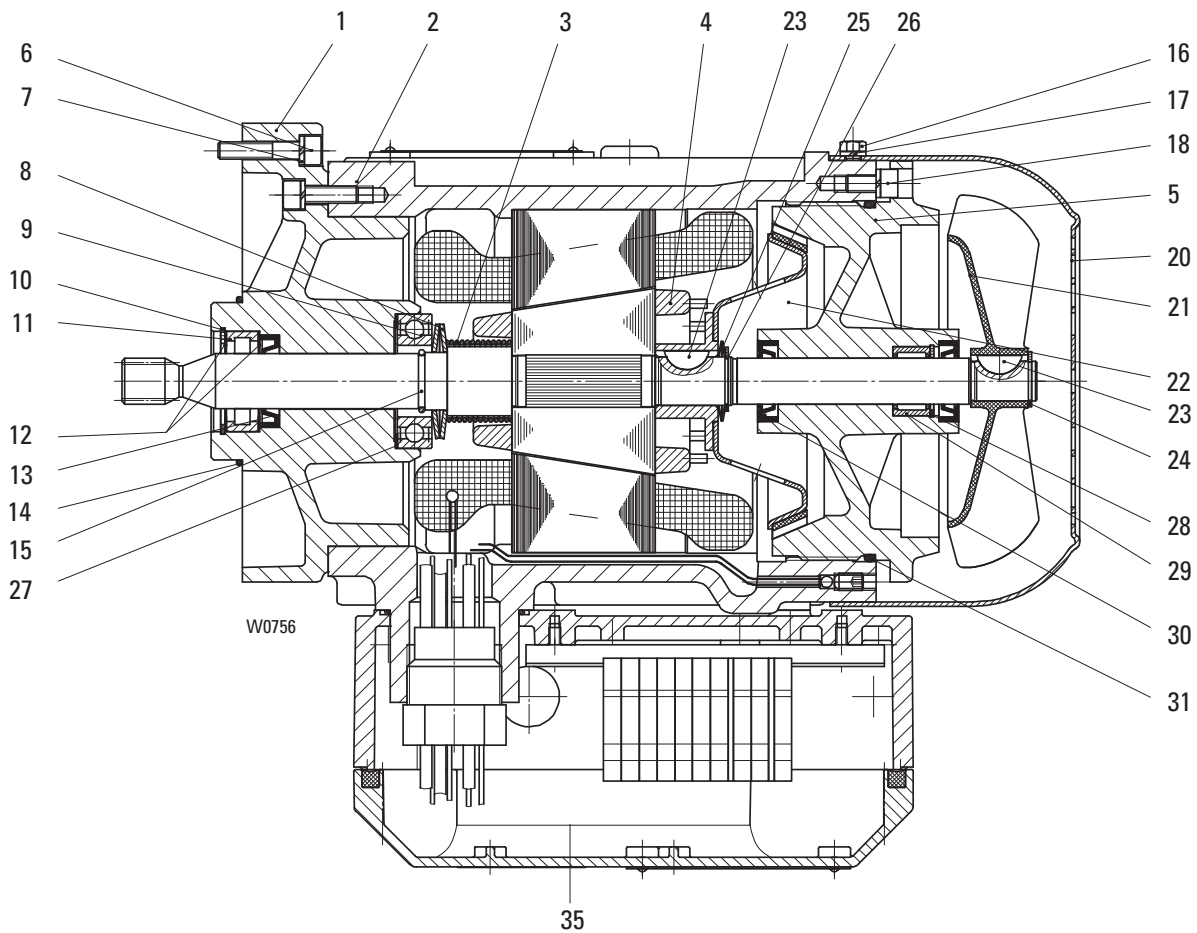

Pos	Teil-Nummer Part-Number	Stück Piece	Beschreibung Description	Benennung Designation
	35 330 56 11 0	1	2/8A05 IIB 1) (Pos.1-31)	Motor
	35 330 57 11 0	1	2/8A05 IIC 1) (Pos.1-31)	Motor
1	35 331 23 03 0	1	IIB	Motorflansch Motor flange
	35 331 24 03 0	1	IIC	
2	35 330 77 14 9	1	1)	Stator Stator
3	33 331 20 94 0	1		Druckfeder Pressure spring
4	35 330 28 13 0	1		Rotor Rotor
5	35 330 05 37 0	1	IIB (Pos.28-31)	Motordeckel Motor cover
	35 330 04 37 0	1	IIC (Pos.28-31)	
	35 330 06 37 0	1	2) (Pos.28-31)	
6	500 976 0	8	M6X30	Zyl.-Schraube Socket head cap screw
7	506 335 0	8	6	Federring Spring washer
8	562 901 0	2	40x20,4x2,65x1,5	Tellerfeder Cup spring
9	560 951 0	1	6005-2RS	Rillenkugellager Grooved ball bearing
10	506 261 0	1	35x1,5	Sicherungsring Circlip
11	506 843 0	1	RNU202E	Zyl.-Rollenlager Roller bearing
12	506 889 0	2	25x35x0,3	Passscheibe Adjusting washer
13	561 893 0	1	A19x32x7	Wellendichtring Shaft seal
14	515 946 0	1	55x2	Runddichtring Round saeling ring
15	507 836 0	1	A20	Spreng ring Spring ring
16	500 419 0	4	M5x8	ISO 4017
17	506 900 0	4	5	SKT-Schraube Hexagon head cap screw
18	500 230 0	4	M6x12	Federring Spring washer
20	35 331 22 40 0	1	ISO 4762-8.8	Zyl.-Schraube Socket head cap screw
21	576 033 0	1	V71 R/14	Lüfterhaube Fan cover
				Lüfterrad Fan wheel

1) Bitte Betriebsspannung und Frequenz angeben.  
2) hartverchromt

1) Please state operating voltage and frequency.  
2) Hard chrome plated



A05 ex

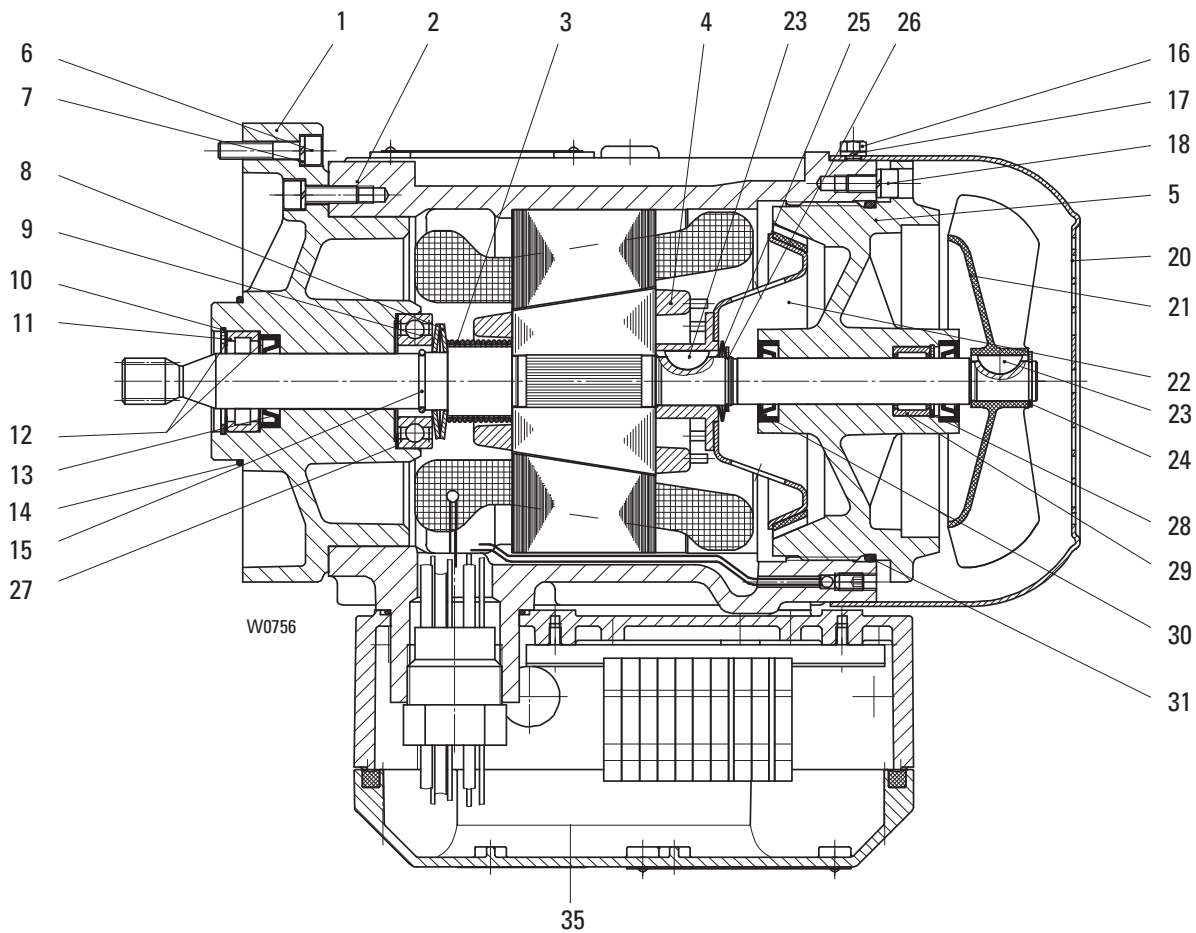

Pos	Teil-Nummer Part-Number	Stück Piece	Beschreibung Description	Benennung	Designation
22	35 330 20 18 0	1		Bremsscheibe	Brake disc
23	537 936 0	2	5x6,5 DIN 6888	Scheibenfeder	Woodruff key
24	506 890 0	1	14x1 DIN 471	Sicherungsring	Circlip
25	562 949 0	2	27,7x17,3x1,45	Tellerfeder	Cup spring
26	506 386 0	1	17x1 DIN 471	Sicherungsring	Circlip
27	507 837 0	1	37x47x0,3 DIN 988	Passscheibe	Adjusting washer
28	... ..	1	M8x40 ISO 4762	Zyl-Schraube	Socket head cap screw
29	... ..	1	RNA 4901 DIN 617	Nadellager	Needle roller bearing
30	... ..	2	AS 16x28x7 NB	Wellendichtring	Shaft seal
31	... ..	1	115x3 NB 70	Runddichtring	Round sealing ring
35	02 220 20 02 0	1		Anschlusskasten	Terminal box



**A1 ex**

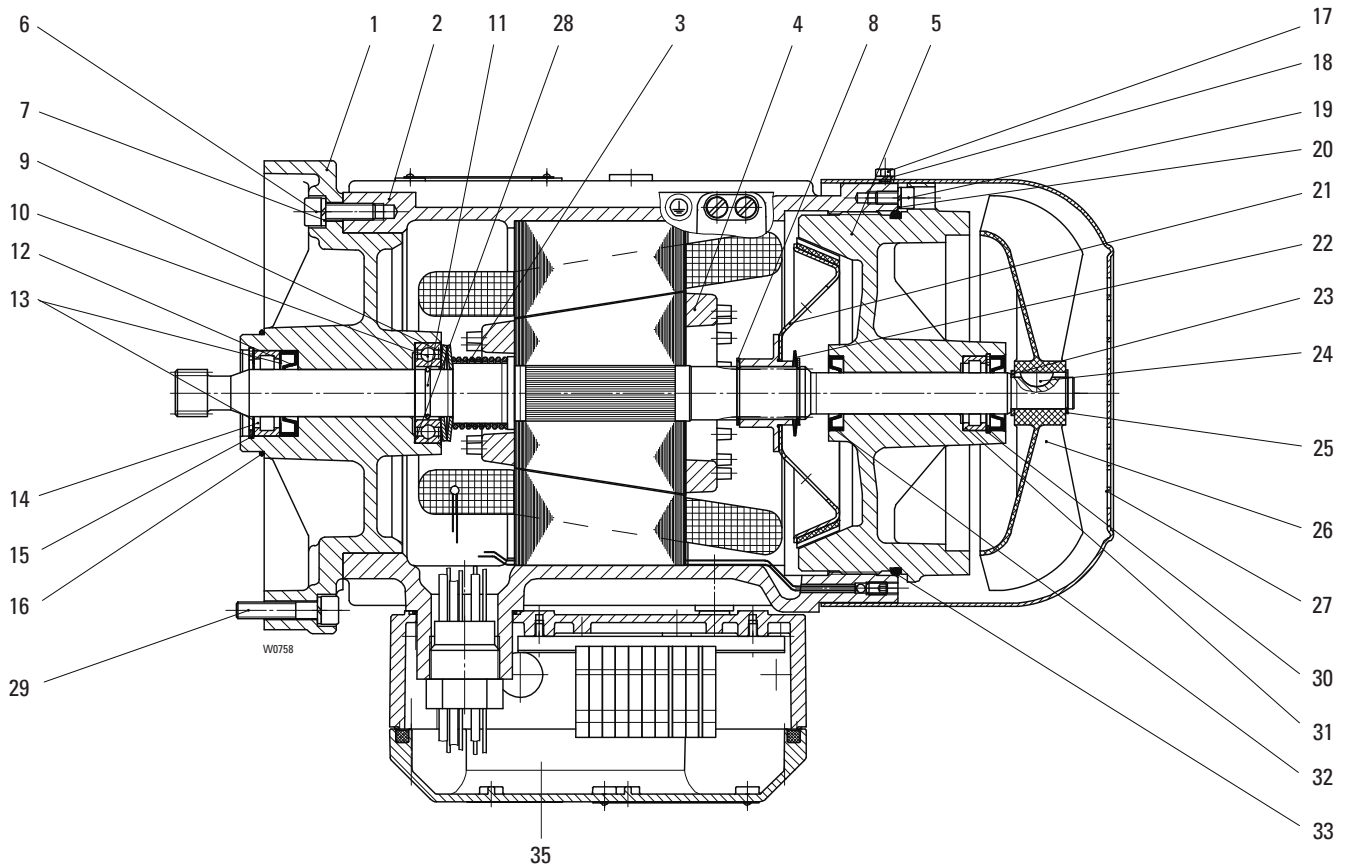

Pos	Teil-Nummer Part-Number	Stück Piece	Beschreibung Description	Benennung Designation
	41 330 42 11 0	1	2/8A1 IIB	Motor
	41 330 43 11 0	1	2/8A1 IIC	Motor
1	41 331 27 03 0	1	IIB	Motorflansch
	41 331 28 03 0	1	IIC	Motor flange
2	41 330 73 14 9	1	2/8A1	Stator
3	38 331 01 94 0	1		Druckfeder
4	41 330 26 13 0	1		Rotor
5	41 330 06 37 0	1	IIB	Motordeckel
	41 330 05 37 0	1	IIC	
	41 330 07 37 0	1	IIC	
6	500 234 0	4	M8x25	Zyl-Schraube
7	506 459 0	4	8	Federring
8	506 097 0	2	25x1,2	Sicherungsring
9	41 331 00 14 0	2	45x22,4x3,05x1,75	Tellerfeder
10	560 951 0	1	6005-2RS	Rillenkugellager
12	561 854 0	1	A22x40x8	Wellendichtring
13	506 805 0	2	28x40x0,5	Passscheibe
14	560 844 0	1	RNU 203 E	Zyl-Rollenlager
15	506 262 0	1	40x1,75	Sicherungsring
16	515 946 0	1	55x2	Runddichtring
17	500 419 0	4	M5x8	Skt-Schraube
18	506 900 0	4	5	Federring
19	500 230 0	4	M6x12	Zyl-Schraube
20	506 335 0	4	6	Federring
21	41 330 20 18 0	1		Bremsscheibe
22	562 939 0	2		Tellerfeder

1) Bitte Betriebsspannung und Frequenz angeben.  
2) hartverchromt

1) Please state operating voltage and frequency.  
2) Hard chrome plated





A1 ex

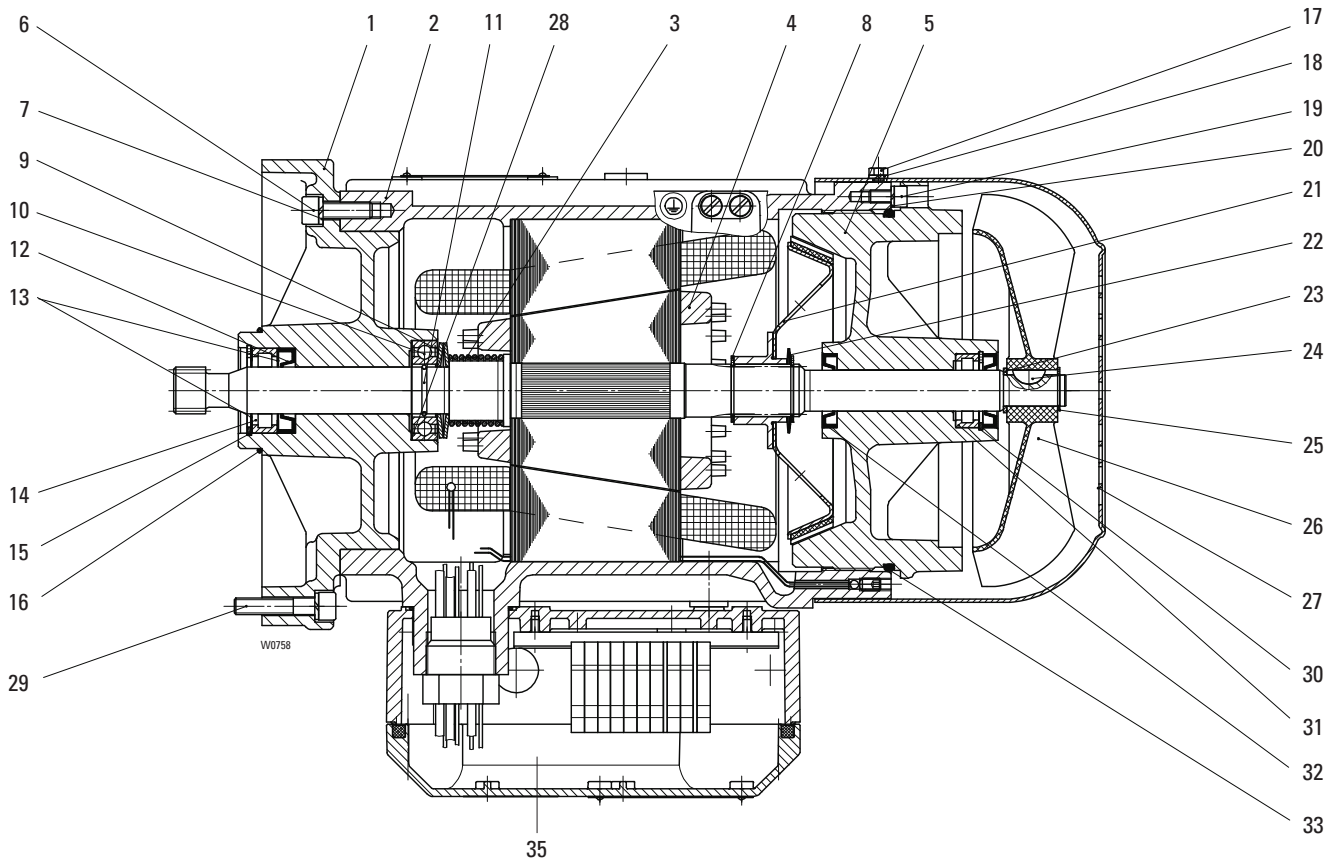

Pos	Teil-Nummer Part-Number	Stück Piece	Beschreibung Description	Benennung Designation
23	506 844 0	1	S15x21x1,5	Stützscheibe
24	537 936 0	1	5x6,5	Scheibenfeder
25	506 093 0	1		Sicherungsring
26	576 030 0	1	V100 R/15	Lüfterrad
27	41 331 21 40 0	1		Lüfterhaube
28	507 837 0	1	37x47x0,3	Passscheibe
29	500 146 0	4	M8x40	Zyl-Schraube
30	.....	1	35x1,5	Sicherungsring
31	.....	1	RNU 202 E	Zyl-Rollenlager
32	.....	2	A19x35x7	Wellendichtring
33	515 980 0	1	160x4	Runddichtring
35	02 220 20 02 0	1		Anschlusskasten





**A1 ex**

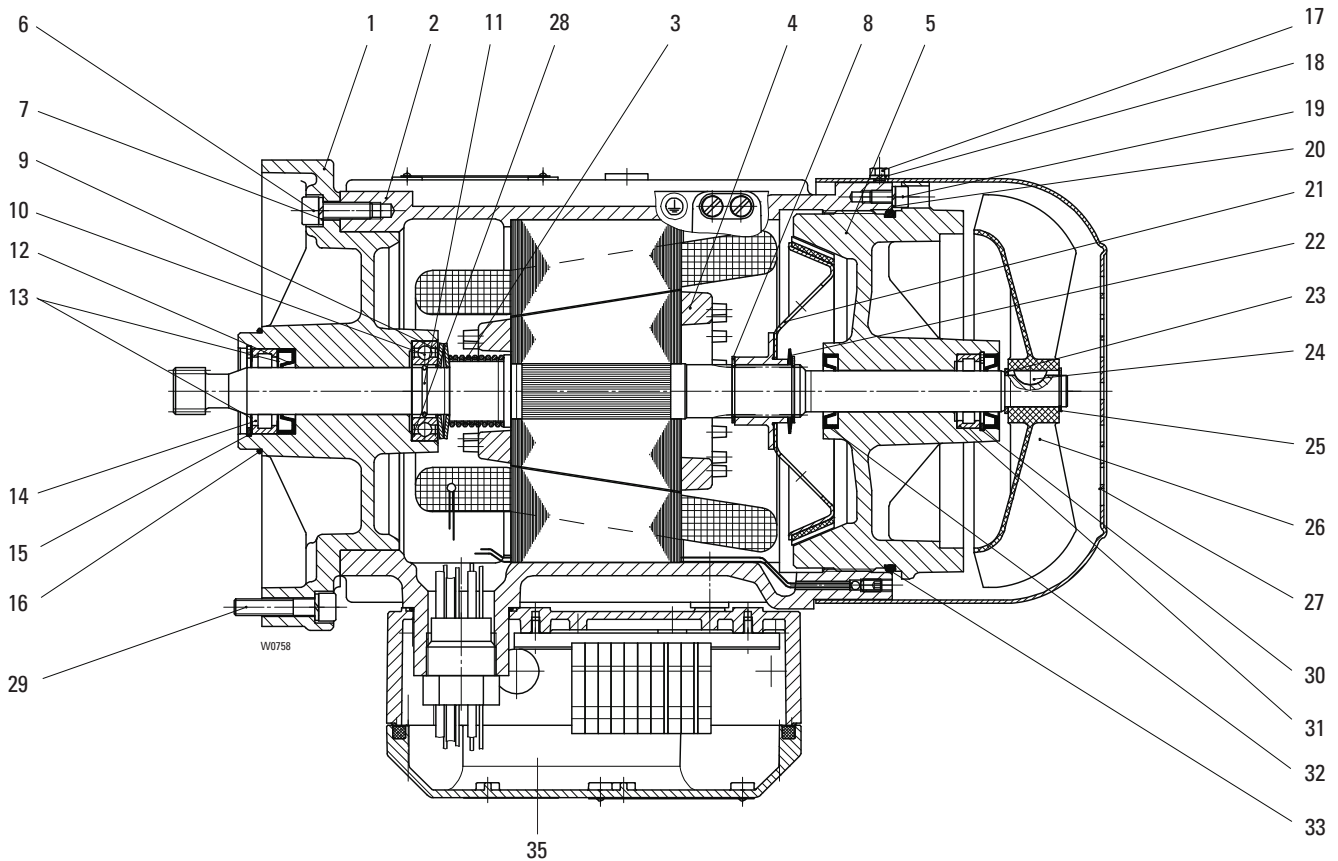

Pos	Teil-Nummer Part-Number	Stück Piece	Beschreibung Description	Benennung Designation
	41 330 40 11 0	1	2/8A1 IIB	Motor
	41 330 41 11 0	1	2/8A1 IIC	Motor
1	41 331 27 03 0	1	IIB	Motorflansch
	41 331 28 03 0	1	IIC	Motorflansch
2	41 330 74 14 9	1	2/8A1	Stator
3	38 331 01 94 0	1		Druckfeder
4	41 330 26 13 0	1		Rotor
5	41 330 06 37 0	1	IIB	Motordeckel
	41 330 05 37 0	1	IIC	Motordeckel
	41 330 07 37 0	1	IIC	Motordeckel
6	500 234 0	4	M8x25	Zyl-Schraube
7	506 459 0	4	8	Federring
8	506 097 0	2	25x1,2	Sicherungsring
9	41 331 00 14 0	2	45x22,4x3,05x1,75	Tellerfeder
10	560 951 0	1	6005-2RS	Rillenkugellager
12	561 854 0	1	A22x40x8	Wellendichtring
13	506 805 0	2	28x40x0,5	Passscheibe
14	560 844 0	1	RNU 203 E	Zyl-Rollenlager
15	506 262 0	1	40x1,75	Sicherungsring
16	515 946 0	1	55x2	Runddichtring
17	500 419 0	4	M5x8	Skt-Schraube
18	506 900 0	4	5	Federring
19	500 230 0	4	M6x12	Zyl-Schraube
20	506 335 0	4	6	Federring
21	41 330 20 18 0	1		Bremsscheibe
22	562 939 0	2		Tellerfeder

1) Bitte Betriebsspannung und Frequenz angeben.  
2) hartverchromt

1) Please state operating voltage and frequency.  
2) Hard chrome plated



A1 ex

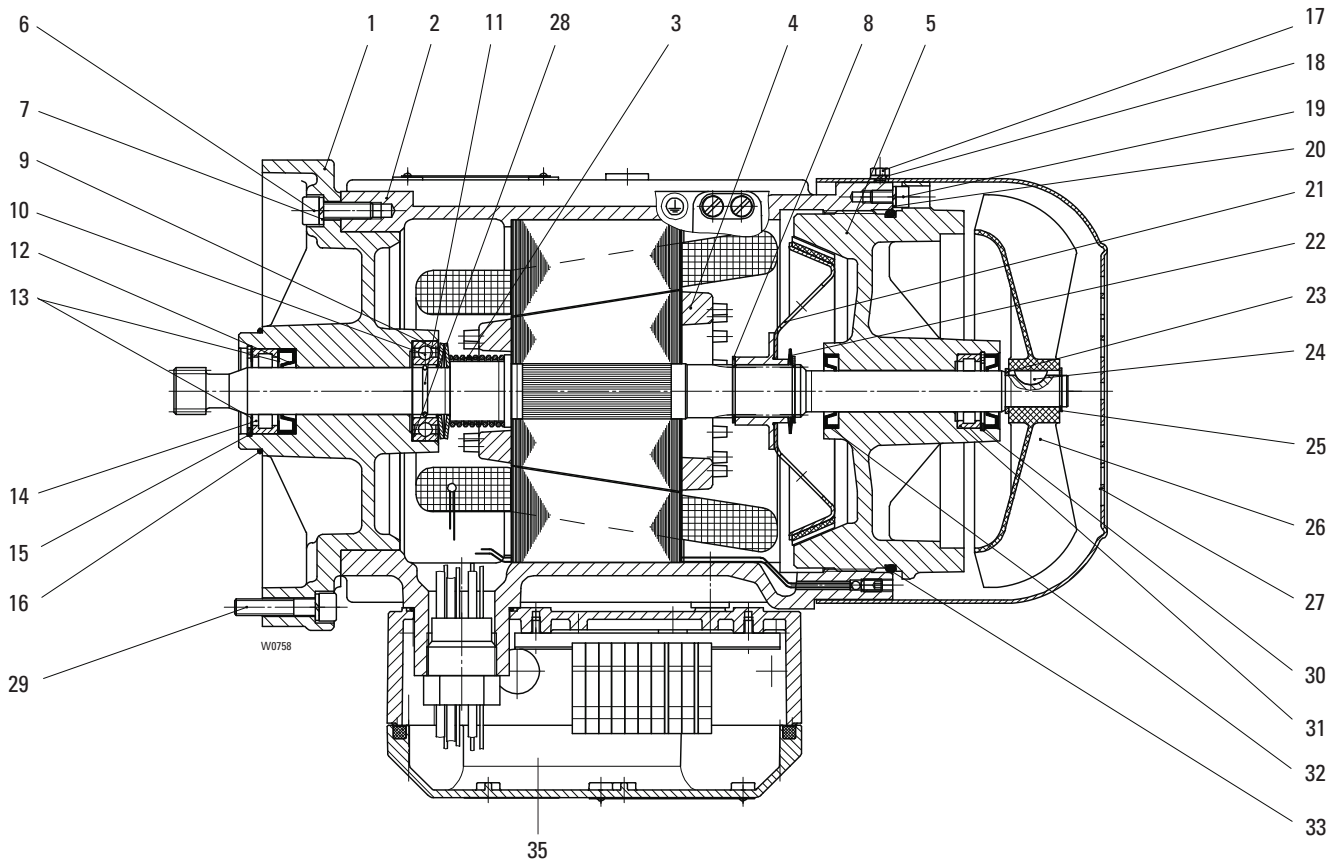

Pos	Teil-Nummer Part-Number	Stück Piece	Beschreibung Description	Benennung Designation
23	506 844 0	1	S15x21x1,5	Stützscheibe
24	537 936 0	1	5x6,5	Scheibefeder
25	506 093 0	1		Sicherungsring
26	576 030 0	1	V100 R/15	Lüfterrad
27	41 331 21 40 0	1		Lüfterhaube
28	507 837 0	1	37x47x0,3	Passscheibe
29	500 146 0	4	M8x40	Zyl-Schraube
30	.....	1	35x1,5	Sicherungsring
31	.....	1	RNU 202 E	Zyl-Rollenlager
32	.....	2	A19x35x7	Wellendichtring
33	515 980 0	1	160x4	Runddichtring
35	02 220 20 02 0	1		Anschlusskasten



**A2 ex**

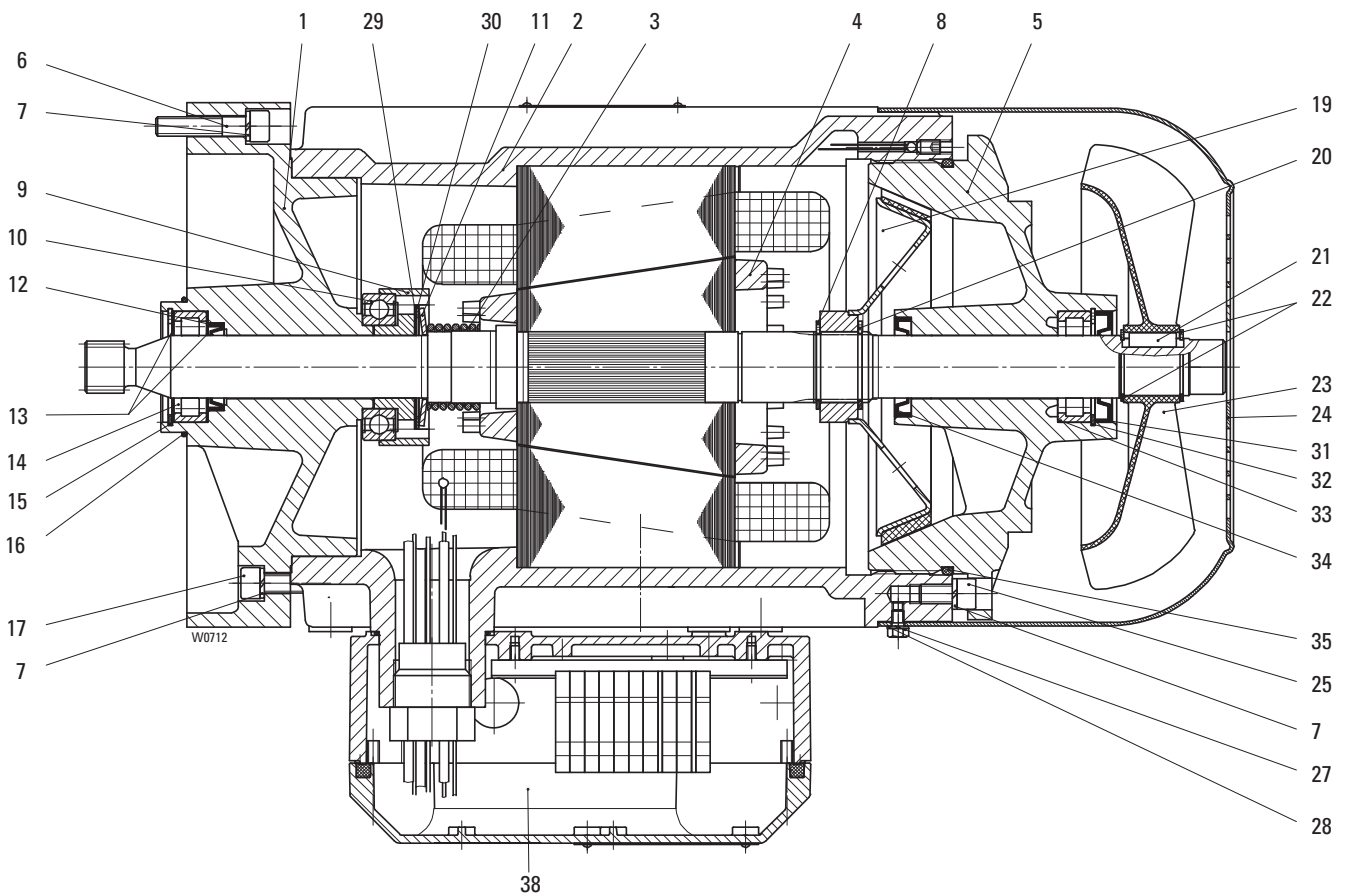

Pos	Teil-Nummer Part-Number	Stück Piece	Beschreibung Description	Benennung Designation
	42 330 52 10 0	1	2/08A2 IIB	Motor
	42 330 53 10 0	1	2/08A2 IIC	Motor
1	42 331 22 03 0	1	IIB	Motorflansch
	42 331 23 03 0	1	IIC	Motor flange
2	42 330 74 14 9	1	2/08A2	Stator
3	42 331 00 94 0	1		Druckfeder
4	42 330 21 13 0	1		Rotor
5	42 330 06 37 0	1	IIB	Motordeckel
	42 330 04 37 0	1	IIC	(Pos.31-35)
	42 330 03 37 0	1	IIC	(Pos.31-35)
6	500 146 0	4	M8x40	Zyl-Schraube
7	506 459 0	12	8	Federring
8	506 098 0	1	30x1,5	Sicherungsring
9	42 331 20 51 0	1		Abstandsring
10	560 067 0	1	6007-2RS-C3	Rillenkugellager
11	42 331 00 14 0	1	500x27,3x3,4x2	Tellerfeder
12	561 822 0	1	A27x37x7	Wellendichtring
13	42 331 00 52 0	2		Scheibe
14	560 845 0	1	RNU 204 E	Zyl-Rollenlager
15	506 106 0	1	47x1,75	Sicherungsring
16	515 946 0	1	55x2	Runddichtring
17	500 234 0	4	M8x25	Zyl-Schraube
19	42 330 20 18 0	1		Bremsscheibe
20	506 569 0	1	A30x1,5L	Sicherungsring
21	537 958 0	1	B6x6x20	Passfeder

1) Bitte Betriebsspannung und Frequenz angeben.  
2) hartverchromt

1) Please state operating voltage and frequency.  
2) Hard chrome plated



A2 ex

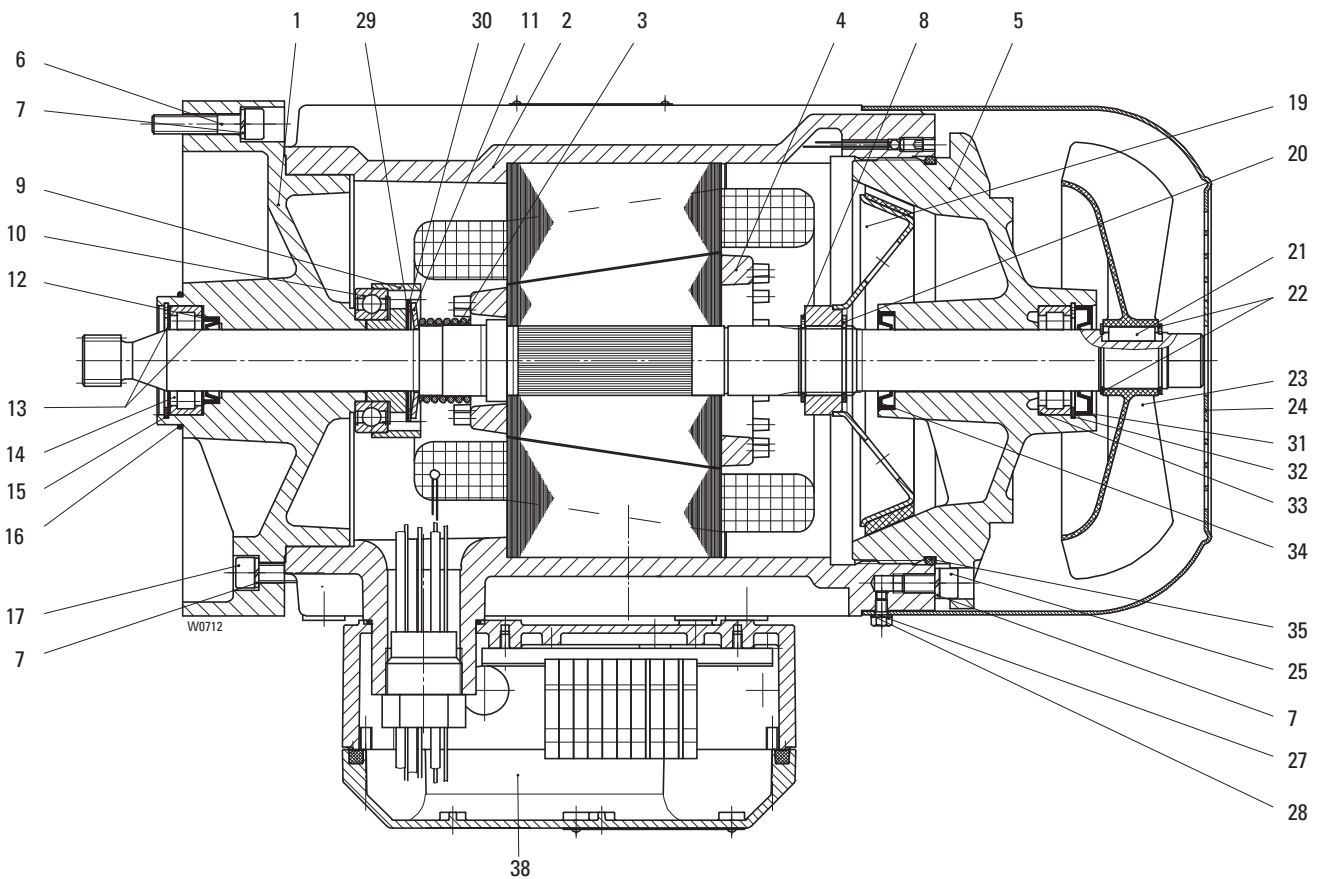

Pos	Teil-Nummer Part-Number	Stück Piece	Beschreibung Description	Benennung	Designation
22	506 428 0	2	24x1,2 DIN 471	Sicherungsring	Circlip
23	576 019 0	1	V100 R/24	Lüfterrad	Fan wheel
24	42 331 20 40 0	1		Lüfterhaube	Fan cover
25	500 144 0	4	M8x16 ISO 4762-8.8	Zyl-Schraube	Socket head cap screw
27	500 419 0	4	M5x8 ISO 4017	Skf-Schraube	Hexagon head cap screw
28	506 042 0	4	A5 DIN 127	Sicherungsring	Circlip
29	507 817 0	3	42x52x0,3 DIN 988	Passscheibe	Ajusting washer
30	507 816 0	1	42x52x1 DIN 988	Passscheibe	Ajusting washer
31	.....	1		Wellendichtring	Shaft seal
32	.....	1	47x1,75 DIN 472	Sicherungsring	Circlip
33	.....	1	RNU 204 E DIN 5412	Zyl-Rollenlager	Roller bearing
34	.....	1	A27x42x7	Wellendichtring	Shaft seal
35	515 980 0	1	160x4 NB 70	Runddichtring	Round sealing ring
38	02 220 20 02 0	1		Anschlusskasten	Terminal box



**Schwungradkupplung**  
**Flywheel coupling**

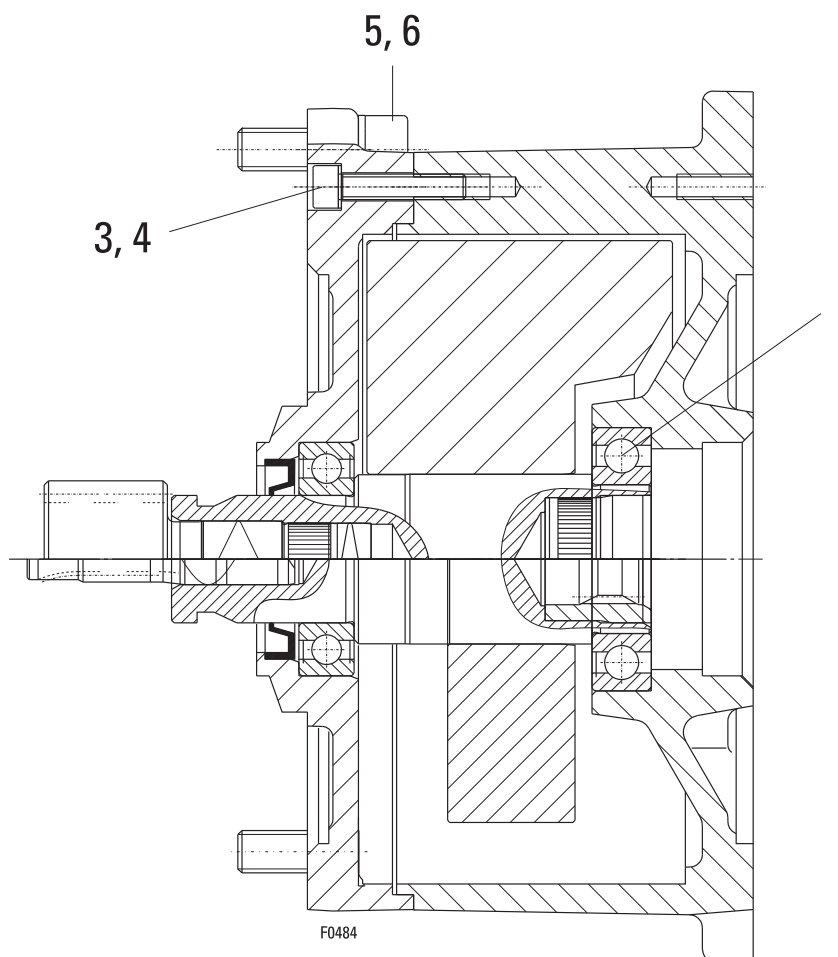

Pos	Teil-Nummer Part-Number	Stück Piece	Beschreibung Description	Benennung	Designation
	21 270 10 32 0	1	SF 11 226 503	Schwungradkupplung	Flywheel coupling
	21 270 11 32 0	1	SF 11 224 503		
		1	SF 11 217 503		
	21 270 12 32 0	1	SF 11 222 503		
		1	SF 11 215 503		
	21 270 13 32 0	1	SF 11 213 503		
		1	SF 11 220 503		
	21 270 14 32 0	1	SF 11 211 503		
	21 270 32 32 0	1	SF 11 217 113		
	21 270 33 32 0	1	SF 11 215 113		
	21 270 34 32 0	1	SF 11 220 113		
		1	SF 11 213 113		
	21 270 35 32 0	1	SF 11 211 113		
	21 270 27 32 0	1	SF 11 213 103		
	21 270 28 32 0	1	SF 11 211 103		
1	560 989 0	1	6007-2Z DIN 625	Rillenkugellager	Grooved ball bearing
3	500 976 0	8	M6x30 ISO 4762-8.8	Zyl-Schraube	Socket head cap screw
4	506 838 0	8	S6	Sicherungsscheibe	Lock washer
5	500 236 0	4	M10x30 DIN 912-8.	Zyl-Schraube	Socket head cap screw
6	506 128 0		VS1	Sicherungsscheibe	Lock washer



Originalteile  
Original parts  
SF 15 2..

Schwungradkupplung  
Flywheel coupling

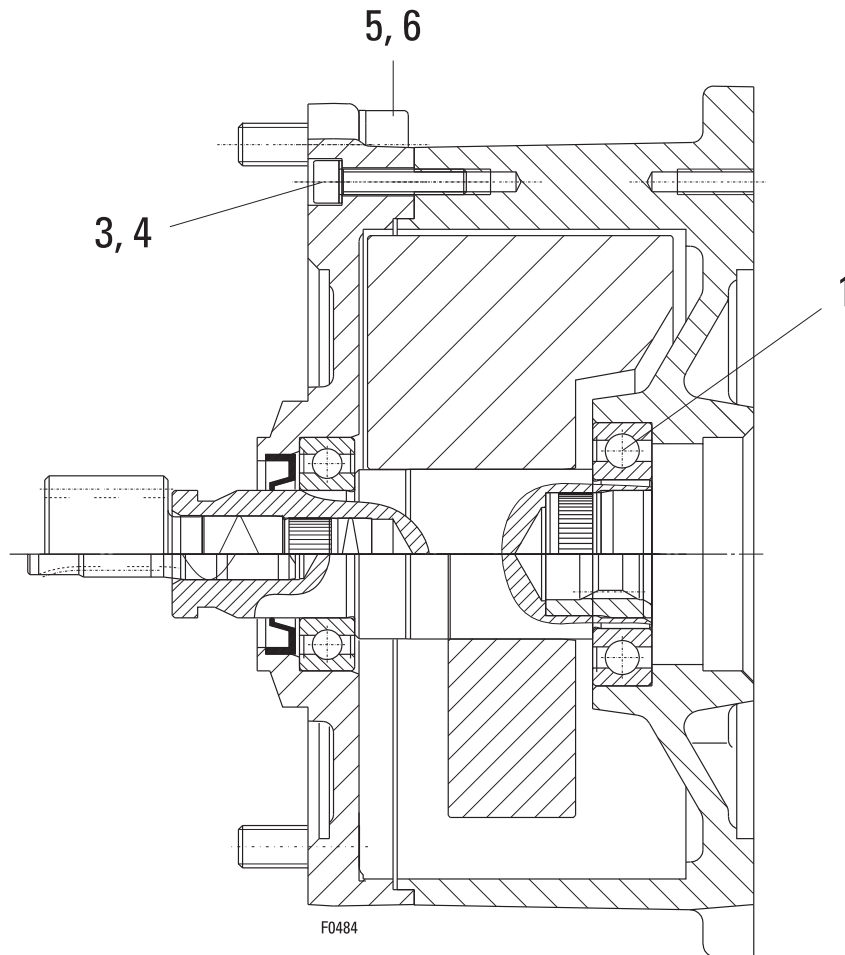

Pos	Teil-Nummer Part-Number	Stück Piece	Beschreibung Description	Benennung	Designation		
	21 270 10 32 0	1	SF 15 226 503	Schwungradkupplung	Flywheel coupling		
	21 270 11 32 0	1	SF 15 224 503				
	21 270 12 32 0	1	SF 15 222 503				
	21 270 13 32 0	1	SF 15 220 503				
	21 270 14 32 0	1	SF 15 218 503				
	21 270 32 32 0	1	SF 15 224 113				
	21 270 33 32 0	1	SF 15 222 113				
	21 270 34 32 0	1	SF 15 218 113				
	21 270 35 32 0	1	SF 15 216 113				
	21 270 37 32 0	1	SF 15 214 113				
	21 270 29 32 0	1	SF 15 216 103				
	21 270 30 32 0	1	SF 15 214 103				
1	560 989 0	1	6007-2Z			Rillenkugellager	Grooved ball bearing
3	500 976 0	8	M6x30			Zyl-Schraube Sicherungsscheibe	Socket head cap screw Lock washer
4	506 838 0	8	S6				
5	500 236 0	4	M10x30	Zyl-Schraube Sicherungsscheibe	Socket head cap screw Lock washer		
6	506 128 0	4	VS10				

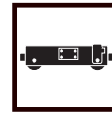

**Schwungradkupplung**  
**Flywheel coupling**

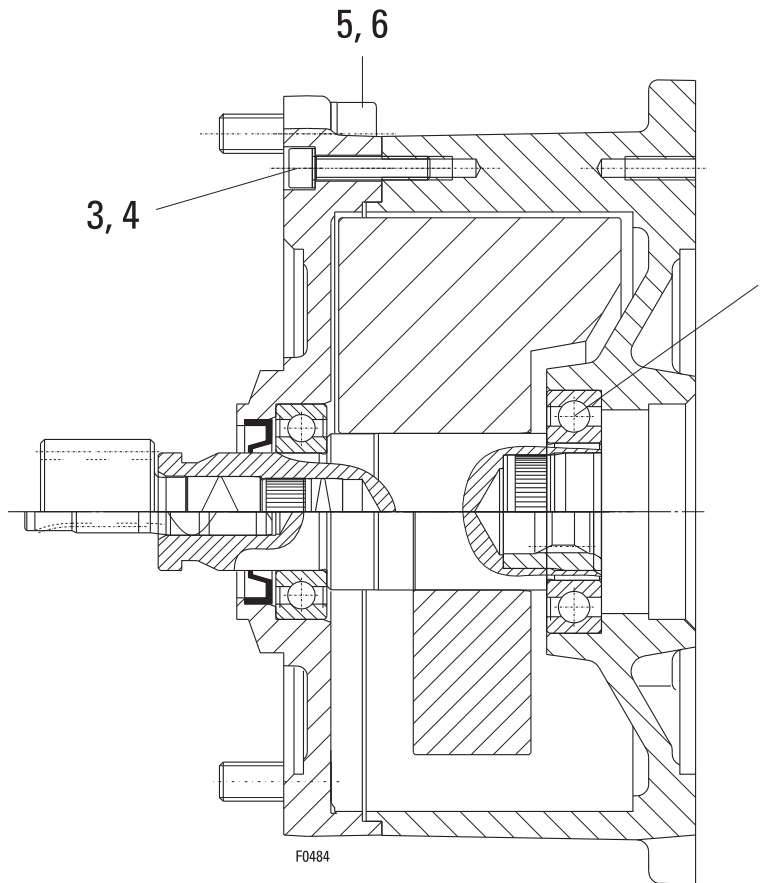

Pos	Teil-Nummer Part-Number	Stück Piece	Beschreibung Description	Benennung	Designation
	21 270 10 32 0	1	SF 25 230 503	Schwungradkupplung	Flywheel coupling
	21 270 11 32 0	1	SF 25 228 503		
		1	SF 25 226 503		
	21 270 13 32 0	1	SF 25 224 503		
		1	SF 25 222 503		
	21 270 15 32 0	1	SF 25 220 503		
	21 270 32 32 0	1	SF 25 228 113		
		1	SF 25 226 113		
	21 270 34 32 0	1	SF 25 224 113		
		1	SF 25 222 113		
	21 270 36 32 0	1	SF 25 220 113		
		1	SF 25 218 113		
	21 270 38 32 0	1	SF 25 216 113		
	21 270 27 32 0	1	SF 25 224 103		
		1	SF 25 222 103		
	21 270 29 32 0	1	SF 25 220 103		
		1	SF 25 218 103		
	21 270 31 32 0	1	SF 25 216 103		
	22 270 11 32 0	1	SF 25 220 203		
			SF 25 218 203		
	22 270 13 32 0	1	SF 25 216 203		
	21 270 38 32 0	1	SF 25 83. 113		
1	560 989 0	1	6007-2Z	Rillenkugellager	Grooved ball bearing
3	500 976 0	8	M6x30	Zyl-Schraube Sicherungsscheibe	Socket head cap screw Lock washer
4	506 838 0	8	S6		
5	500 236 0	4	M10x30	Zyl-Schraube Sicherungsscheibe	Socket head cap screw Lock washer
6	506 128 0	4	VS10		



Originalteile  
Original parts  
SF 35 ...

Schwungradkupplung  
Flywheel coupling

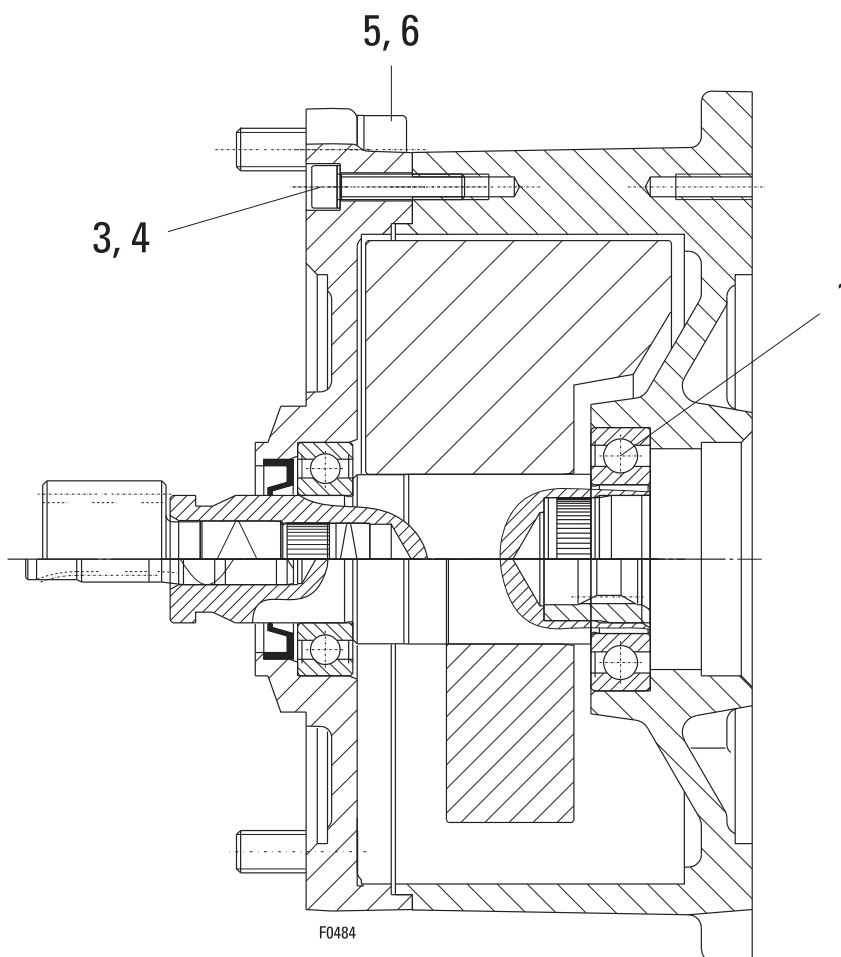

Pos	Teil-Nummer Part-Number	Stück Piece	Beschreibung Description	Benennung	Designation
	21 270 33 32 0	1	SF 35 230 113	Schwungradkupplung	Flywheel coupling
	21 270 34 32 0	1	SF 35 228 113		
		1	SF 35 226 113		
	21 270 26 32 0	1	SF 35 230 103		
	21 270 27 32 0	1	SF 35 228 103		
		1	SF 35 226 103		
	21 270 29 32 0	1	SF 35 224 103		
		1	SF 35 222 103		
	22 270 10 32 0	1	SF 35 228 203		
		1	SF 35 226 203		
	22 270 11 32 0	1	SF 35 216 203		
		1	SF 35 224 203		
		1	SF 35 222 203		
	22 270 13 32 0	1	SF 35 220 203		
	21 270 38 32 0	1	SF 35 83. 113		
1	560 989 0	1	6007-2Z	Rillenkugellager	Grooved ball bearing
3	500 976 0	8	M6x30	Zyl-Schraube Sicherungsscheibe	Socket head cap screw Lock washer
4	506 838 0	8	S6		
5	500 236 0	4	M10x30	Zyl-Schraube Sicherungsscheibe	Socket head cap screw Lock washer
6	506 128 0	4	VS10		



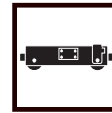

**Getriebe/gear**

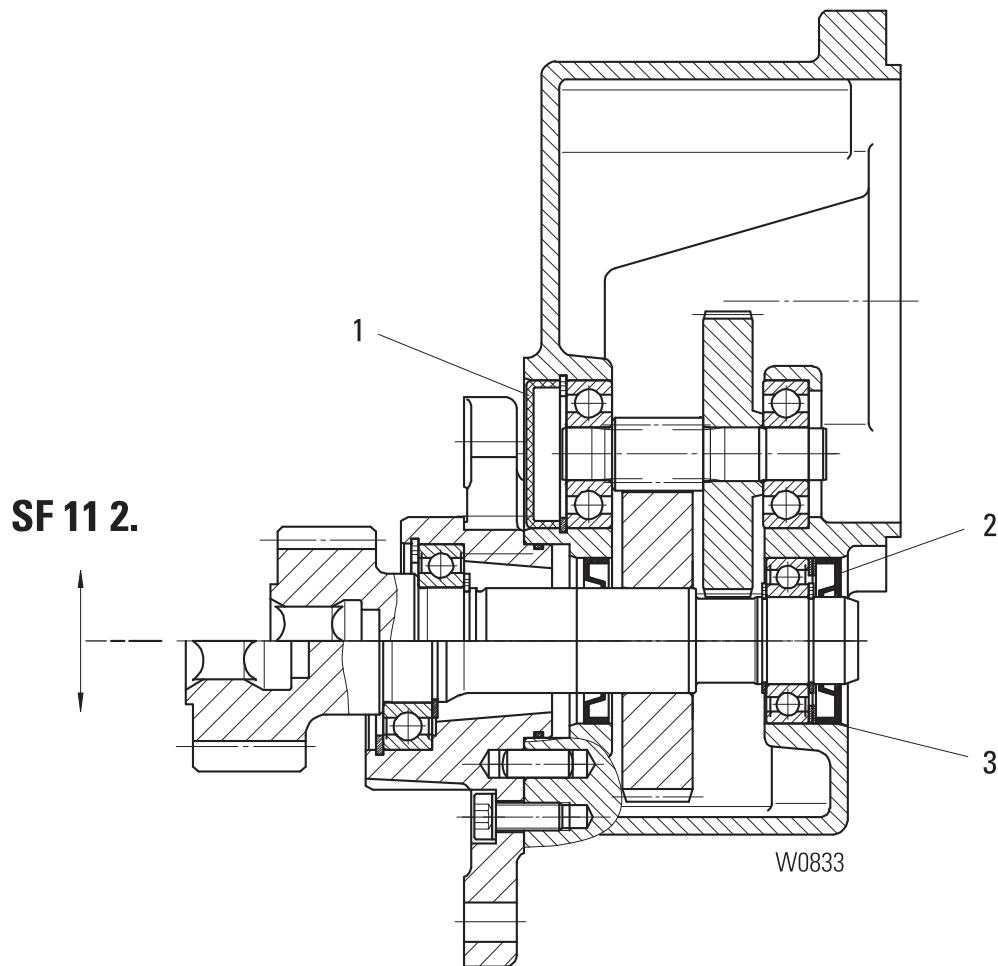

Pos	Teil-Nummer Part-Number	Stück Piece	Beschreibung Description	Benennung Designation	Designation
	21 270 24 30 0	1	SF11 226	Getriebe	Gear
	21 270 25 30 0	1	SF11 224		
	21 270 26 30 0	1	SF11 222		
	21 270 27 30 0	1	SF11 220		
	21 270 28 30 0	1	SF11 217		
	21 270 29 30 0	1	SF11 215		
	21 270 30 30 0	1	SF11 213		
	21 270 31 30 0	1	SF11 211		
1	518 036 0	1	42x9,5		
2	561 120 0	1	25x47x7	Wellendichtring	Shaft seal
3	507 876 0	1	37x47x1	Passscheibe	Adjusting washer
			DIN 6760 NB DIN 988		

1) Getriebe bis auf gekennzeichnete Teile nur komplett lieferbar.  
Ohne Getriebeöl: Erforderliche Menge siehe Betriebsanleitung

1) Gear only available as complete unit except the signed parts  
Without gear oil: amount required see operating instruction



**Originalteile**  
**Original parts**  
**SF 15 2..**

**Getriebe/gear**

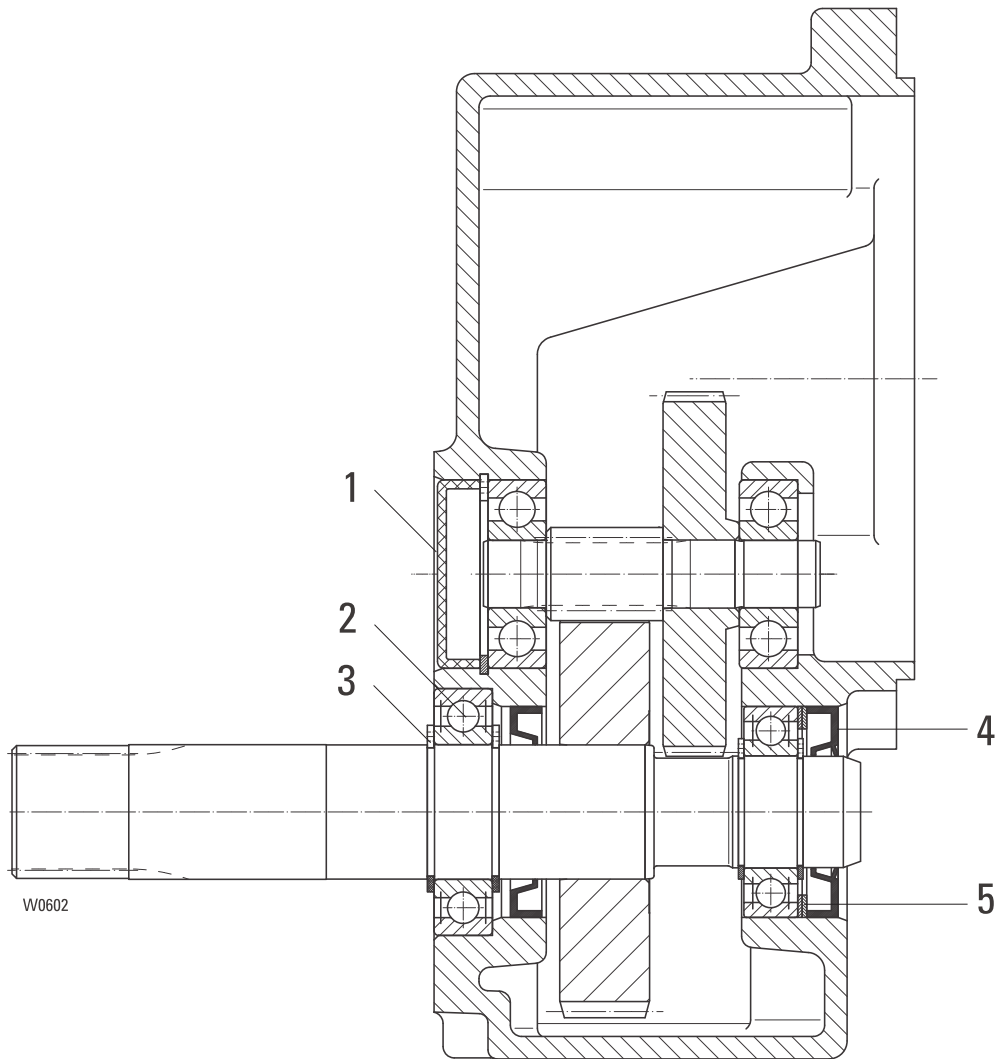

Pos	Teil-Nummer Part-Number	Stück Piece	Beschreibung Description	Benennung Designation
	21 270 11 30 0	1	SF15 226	Getriebe Gear
	21 270 12 30 0	1	SF15 224	
	21 270 13 30 0	1	SF15 222	
	21 270 14 30 0	1	SF15 220	
	21 270 15 30 0	1	SF15 218	
	21 270 16 30 0	1	SF15 216	
	21 270 17 30 0	1	SF15 214	
1	518 036 0	1		Verschlusskappe End cap
2	560 952 0	1	6006-2RS DIN 625	Rillenkugellager Grooved ball bearing
3	506 098 0	2	30x1,5 DIN 471	Sicherungsring Locking ring
4	561 120 0	1	25x47x7 DIN 6760 NB	Wellendichtring Shaft seal
5	507 876 0	2	37x47x1 DIN 988	Passscheibe Adjusting washer

1) Getriebe bis auf gekennzeichnete Teile nur komplett lieferbar.  
Ohne Getriebeöl: Erforderliche Menge siehe Betriebsanleitung

1) Gear only available as complete unit except the signed parts  
Without gear oil: amount required see operating instruction



## Zwischengetriebe/Intermediate gear

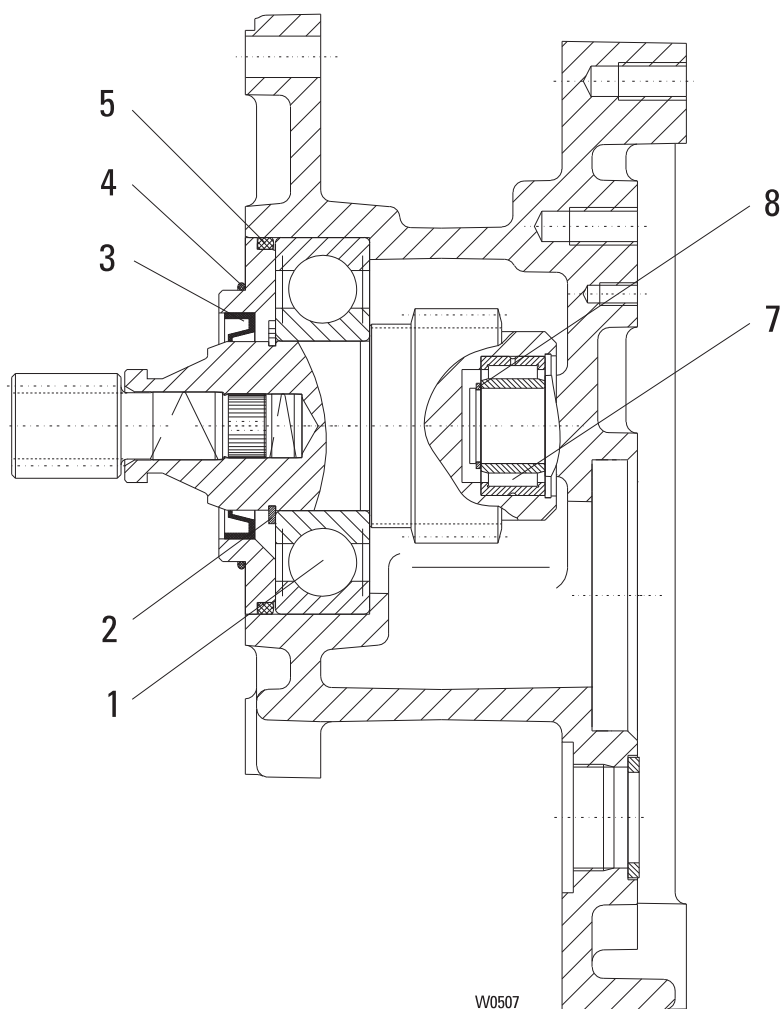

Pos	Teil-Nummer Part-Number	Stück Piece	Beschreibung Description	Benennung	Designation
	24 270 39 30 0	1	SF 25 832	Zwischengetriebe	Intermediate gear
		1	SF 25 834		
	24 270 37 30 0	1	SF 25 830		
1	560 829 0	1	6309-27	Rillenkugellager	Grooved ball bearing
2	506 101 0	1	45x1,75	Sicherungsring	Locking ring
3	561 026 0	1	45x60x8 NB	Wellendichtring	Shaft seal
4	515 953 0	1	70x2	Runddichtring	Round sealing ring
5	515 970 0	1	90x4	Runddichtring	Round sealing ring
7	560 995 0	1	NA 4904	Nadellager	needle roller bearing
8	507 122 0	1	SW 20	Sprengerring	Circlip



**Originalteile**  
**Original parts**  
**SF 25 ...**

**Getriebe/gear**

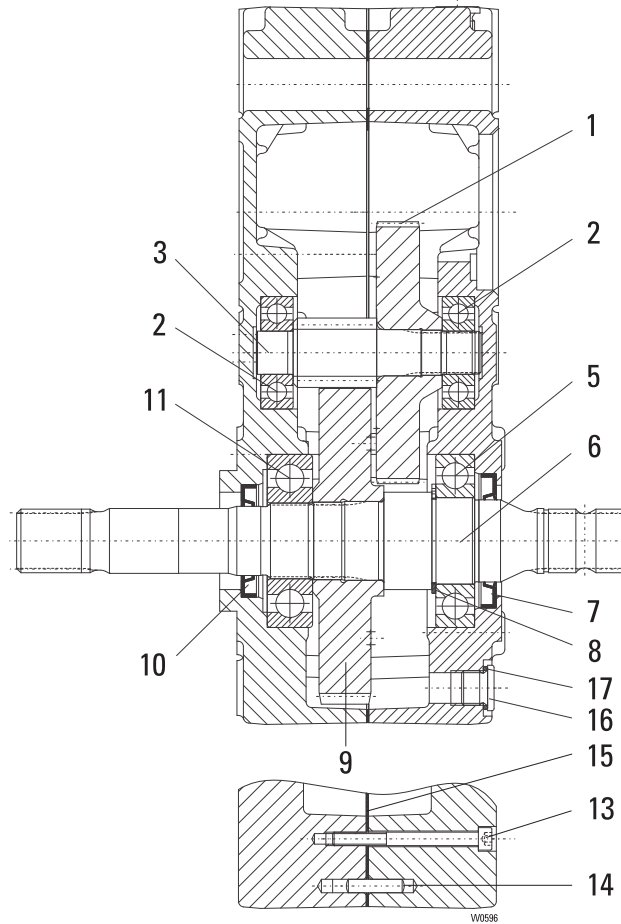

Pos	Teil-Nummer Part-Number	Stück Piece	Beschreibung Description	Benennung	Designation
	22 270 00 30 0	1	SF 25 228, SF 25 834 1)	Getriebe	Gear
	22 270 01 30 0	1	SF 25 226, SF 25 832 1)		
	22 270 02 30 0	1	SF 25 224, SF 25 830 1)		
	22 270 03 30 0	1	SF 25 222 1)		
	22 270 04 30 0	1	SF 25 220 1)		
	22 270 05 30 0	1	SF 25 218 1)		
	22 270 06 30 0	1	SF 25 216 1)		
	22 270 16 30 0	1	SF 25 230 1)		
1	22 273 05 11 0	1	SF 25 228, SF 25 226 SF 25 834, SF 25 832	Zahnrad	Toothed wheel
	22 273 04 11 0	1	SF 25 224, SF 25 222 SF 25 830		
	22 273 03 11 0	1	SF 25 220, SF 25 218		
	22 273 02 11 0	1	SF 25 216		
	22 273 08 11 0	1	SF 25 230		
2	560 053 0	2	6304 DIN 625	Rillenkugellager	Grooved ball bearing
3	23 273 00 19 0	1	SF 25 228, SF 25 224 SF 25 220, SF 25 216, SF 25 230	Ritzelwelle	Pinion shaft
		1	SF 25 834, SF 25 830		
5	23 273 01 19 0	1	SF 25 226, SF 25 222 SF 25 218 SF 25 832		
	560 986 0	1	6208-C3 DIN 625	Rillenkugellager	Grooved ball bearing
6	22 273 04 23 0	1		Abtriebswelle	Drive shaft
7	561 125 0	1	38x62x7 DIN 3760	Wellendichtring	Shaft seal
8	506 082 0	1	S40x50x2,5 DIN 988	Stützscheibe	Supporting washer
9	22 273 07 11 0	1	SF 25 228, SF 25 224 SF 25 220, SF 25 216, SF 25 230	Zahnrad	Toothed wheel
		1	SF 25 832, SF 25 830		
	22 273 06 11 0	1	SF 25 226, SF 25 222 SF 25 218 SF 25 832		
10	561 992 0	1	32x52x7 DIN 3760	Wellendichtring	Shaft seal
11	560 061 0	1	6307 DIN 625	Rillenkugellager	Grooved ball bearing
13	500 804 0	8	M6x65 ISO 4762	Zyl.-Schraube	Socked head cap screw
14	504 029 0	4	6m6x24 ISO 2338	Zyl.-Stift	Pin
15	22 273 00 95 0	1		Dichtung	Seal
16	503 954 0	2		Verschlussschraube	Locking bolt
17	515 004 0	2	C16X20 DIN 7603	Dichtring	Washer

Ohne Getriebeöl: Erforderliche Menge siehe Betriebsanleitung

Without gear oil: amount required see operating instruction



## Zwischengetriebe/Intermediate gear

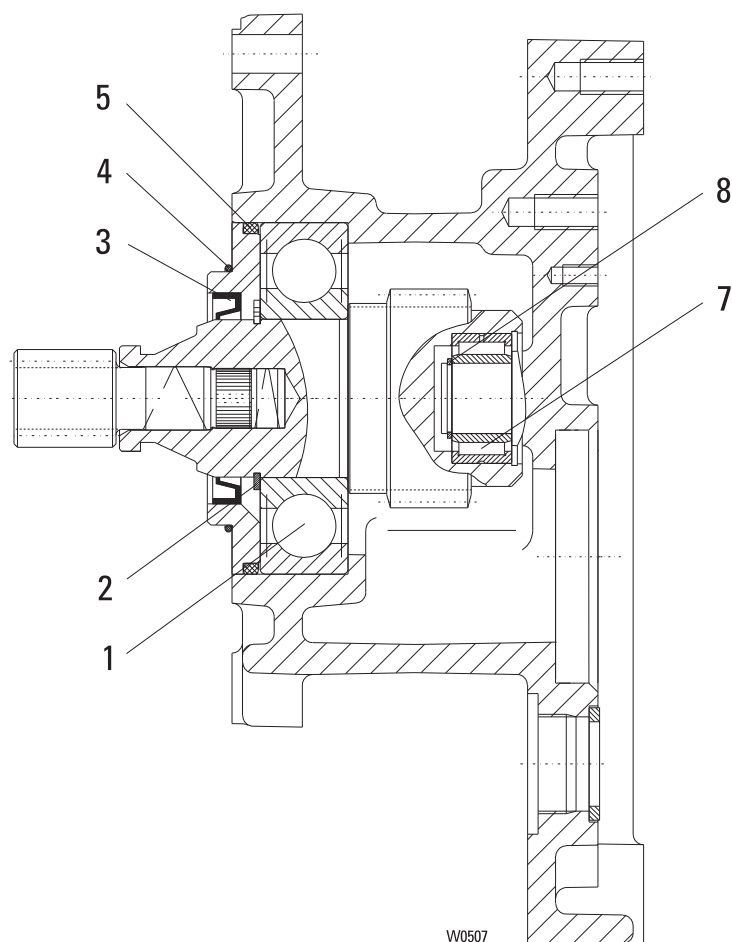

W0507

Pos	Teil-Nummer Part-Number	Stück Piece	Beschreibung Description	Benennung	Designation
	24 270 40 30 0	1	SF 35 836	Zwischengetriebe	Intermediate gear
	24 270 37 30 0	1	SF 35 834		
		1	SF 35 832		
1	560 829 0	1	6309-27	Rillenkugellager	Grooved ball bearing
2	506 101 0	1	45x1,75	Sicherungsring	Locking ring
3	561 026 0	1	45x60x8 NB	Wellendichtring	Shaft seal
4	515 953 0	1	70x2	Runddichtring	Round sealing ring
5	515 970 0	1	90x4	Runddichtring	Round sealing ring
7	560 995 0	1	NA 4904	Nadellager	needle roller bearing
8	507 122 0	1	SW 20	Sprengerring	Circlip



Originalteile  
Original parts  
SF 35 ...

Getriebe/gear

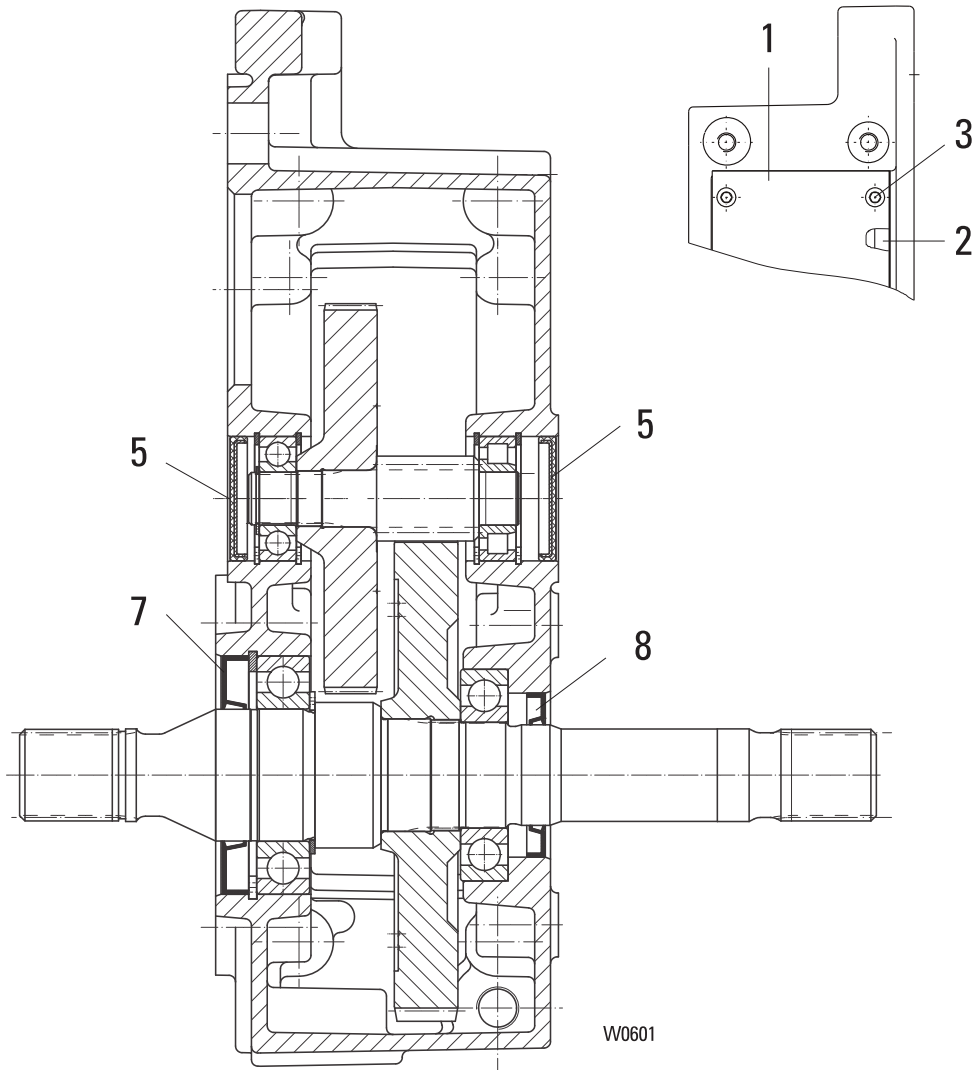

W0601

Pos	Teil-Nummer Part-Number	Stück Piece	Beschreibung Description	Benennung	Designation
	23 270 10 30 0	1	SF 35 230	Getriebe	Gear
		1	SF 35 836		
	23 270 11 30 0	1	SF 35 228		
		1	SF 35 834		
	23 270 12 30 0	1	SF 35 226		
		1	SF 35 832		
	23 270 13 30 0	1	SF 35 224		
	23 270 14 30 0	1	SF 35 222		
	23 270 15 30 0	1	SF 35 220		
1	23 273 00 96 0	1			
2	23 273 00 95 0	1		Dichtung	Seal
3	500 810 0	8	M6x16 DIN 6912-8.8	Zyl-Schraube	Socket head cap screw
5	518 041 0	1	47x6,5	Verschlusskappe	End cap
7	561 126 0	1	AS50x90x10	Wellendichtring	Shaft seal
8	561 125 0	1	AS38x62x7	Wellendichtring	Shaft seal

1) Getriebe bis auf gekennzeichnete Teile nur komplett lieferbar.  
Ohne Getriebeöl: Erforderliche Menge siehe Betriebsanleitung

1) Gear only available as complete unit except the signed parts  
Without gear oil: amount required see operating instruction.



**Getriebe/gear**

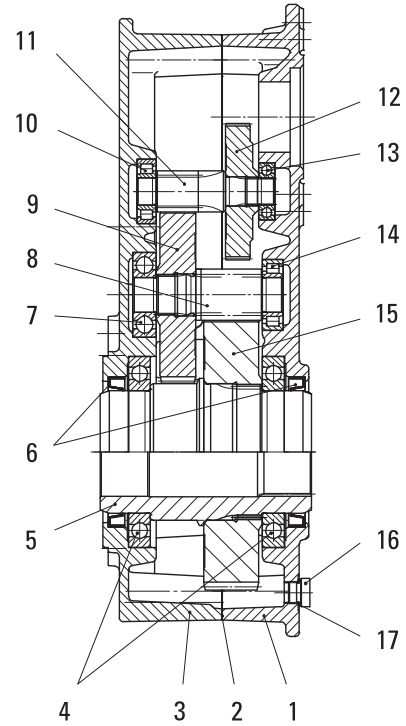
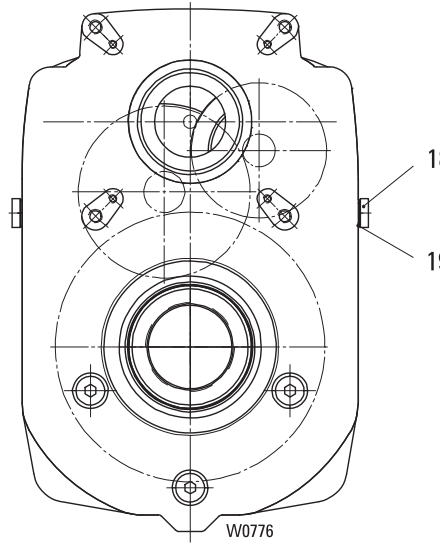
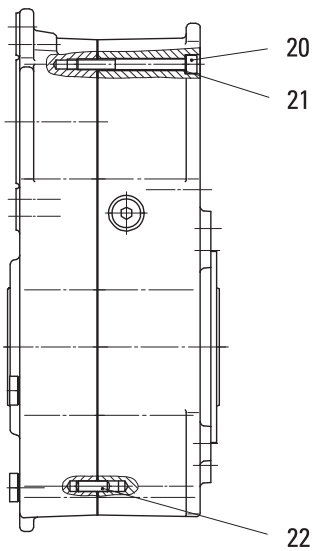

Pos	Teil-Nummer Part-Number	Stück Piece	Beschreibung Description	Benennung Designation	
	15 270 11 30 0	1	SA-. 57 42 (Pos.1-22)	Getriebe Gear	
	15 270 12 30 0	1	SA-. 57 40 (Pos.1-22)		
	15 270 13 30 0	1	SA-. 57 38 (Pos.1-22)		
	15 270 14 30 0	1	SA-. 57 36 (Pos.1-22)		
	15 270 15 30 0	1	SA-. 57 34 (Pos.1-22)		
	15 270 16 30 0	1	SA-. 57 32 (Pos.1-22)		
	15 270 17 30 0	1	SA-. 57 30 (Pos.1-22)		
	15 270 18 30 0	1	SA-. 57 28 (Pos.1-22)		
	15 270 19 30 0	1	SA-. 57 26 (Pos.1-22)		
	15 270 20 30 0	1	SA-. 57 24 (Pos.1-22)		
	15 270 21 30 0	1	SA-. 57 22 (Pos.1-22)		
1	15 277 04 01 0	1			Getriebegehäuse Gear box
2	33 255 00 95 0	1			Dichtung Seal
3	15 277 02 02 0	1			Getriebedeckel Gear cap
4	560 856 0	2	16018-C3 DIN 625	Rillenkugellager Grooved ball bearing	
5	15 277 01 23 0	1		Abtriebswelle Drive shaft	
6	561 806 0	2	A9x110x12	Wellendichtring Shaft seal	
7	560 020 0	1	6305 DIN 625	Rillenkugellager Grooved ball bearing	
8	15 277 13 19 0	1	SA-. 57 42	Ritzelwelle Pinion	
		1	SA-. 57 36		
		1	SA-. 57 38		
		1	SA-. 57 32		
		1	SA-. 57 24		
	15 277 14 19 0	1	SA-. 57 40		
		1	SA-. 57 34		
		1	SA-. 58 30		
		1	SA-. 57 28		
		1	SA-. 57 26		
		1	SA-. 57 22		
9	15 277 13 11 0	1	SA-. 57 42	Zahnrad Toothed wheel	
		1	SA-. 57 40		
		1	SA-. 57 36		
		1	SA-. 57 34		
	15 277 14 11 0	1	SA-. 57 38		
		1	SA-. 57 32		
		1	SA-. 57 30		
	15 277 15 11 0	1	SA-. 57 28		
		1	SA-. 57 26		
		1	SA-. 57 24		
		1	SA-. 57 22		



**Originalteile**  
**Original parts**  
**SA-D 57**

**Getriebe/gear**

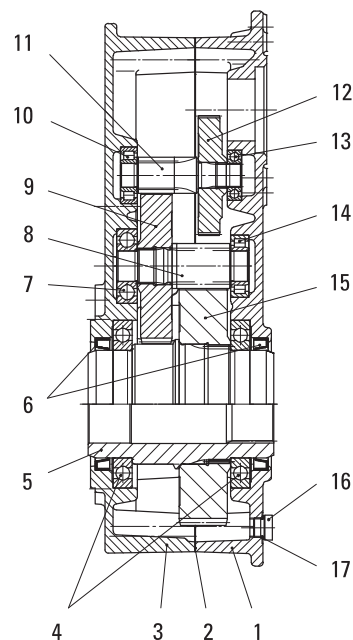
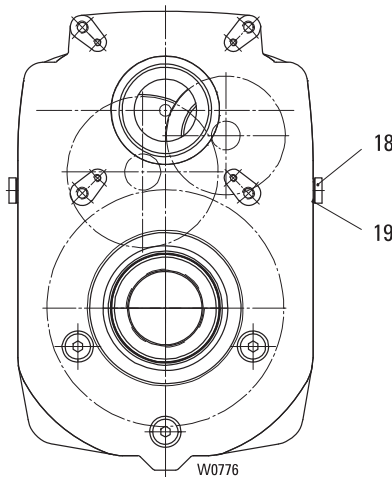
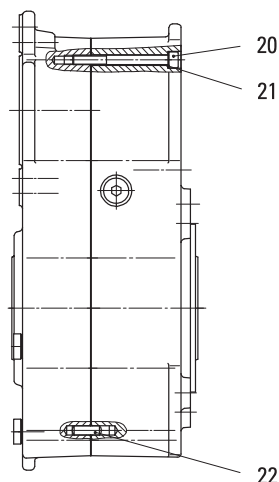

Pos	Teil-Nummer Part-Number	Stück Piece	Beschreibung Description	Benennung Designation
10	560 812 0	1	NJ 204 EC DIN 5412	Zyl-Rollenlager Roller bearing
11	15 277 10 19 0	1	SA-. 57 42 z=12	Ritzelwelle Pinion
		1	SA-. 57 40	
		1	SA-. 57 36	
		1	SA-. 57 34	
	15 277 11 19 0	1	SA-. 57 38 z=17	
		1	SA-. 57 32	
		1	SA-. 57 30	
	15 277 12 19 0	1	SA-. 57 28 z=24	
		1	SA-. 57 26	
		1	SA-. 57 24	
		1	SA-. 57 22	
12	15 277 10 11 0	1	SA-. 57 42 z=91	Zahnrad Toothed wheel
		1	SA-. 57 40	
		1	SA-. 57 38	
	15 277 11 11 0	1	SA-. 57 36 z=56	
		1	SA-. 57 34	
		1	SA-. 57 32	
		1	SA-. 57 30	
		1	SA-. 57 28	
		1	SA-. 57 26	
	15 277 12 11 0	1	SA-. 57 24 z=35	
		1	SA-. 57 22	
13	560 044 0	1	6004-2RS DIN 625	Rillenkugellager Grooved ball bearing
14	560 131 0	1	NJ205 E DIN 5412	Zyl-Rollenlager Roller bearing
15	15 277 16 11 0	1	SA-. 57 42 z=79	Zahnrad Toothed wheel
		1	SA-. 57 38	
		1	SA-. 57 36	
		1	SA-. 57 32	
		1	SA-. 57 28	
		1	SA-. 57 24	
	15 277 17 11 0	1	SA-. 57 40 z=77	
		1	SA-. 57 34	
		1	SA-. 57 30	
		1	SA-. 57 26	
		1	SA-. 57 22	
16	503 912 0	4	AM16x1,5 DIN 7604	Verschlussschraube Screw plug
17	515 004 0	4	C16x20 DIN 7603	Dichtring Sealing ring
18	32 250 00 57 0	1		Verschlussschraube Screw plug
19	515 004 0	1	C16x20 DIN 7603	Dichtring Sealing ring
20	500 859 0	10	M8x80 ISO 4762	Zyl-Schraube Socket head cap screw
21	506 839 0	10	S8	Sicherungsscheibe Locking disc
22	504 960 0	2	8m6x24 ISO 2338	Zyl-Stift Dowel pin





**Getriebe/gear**

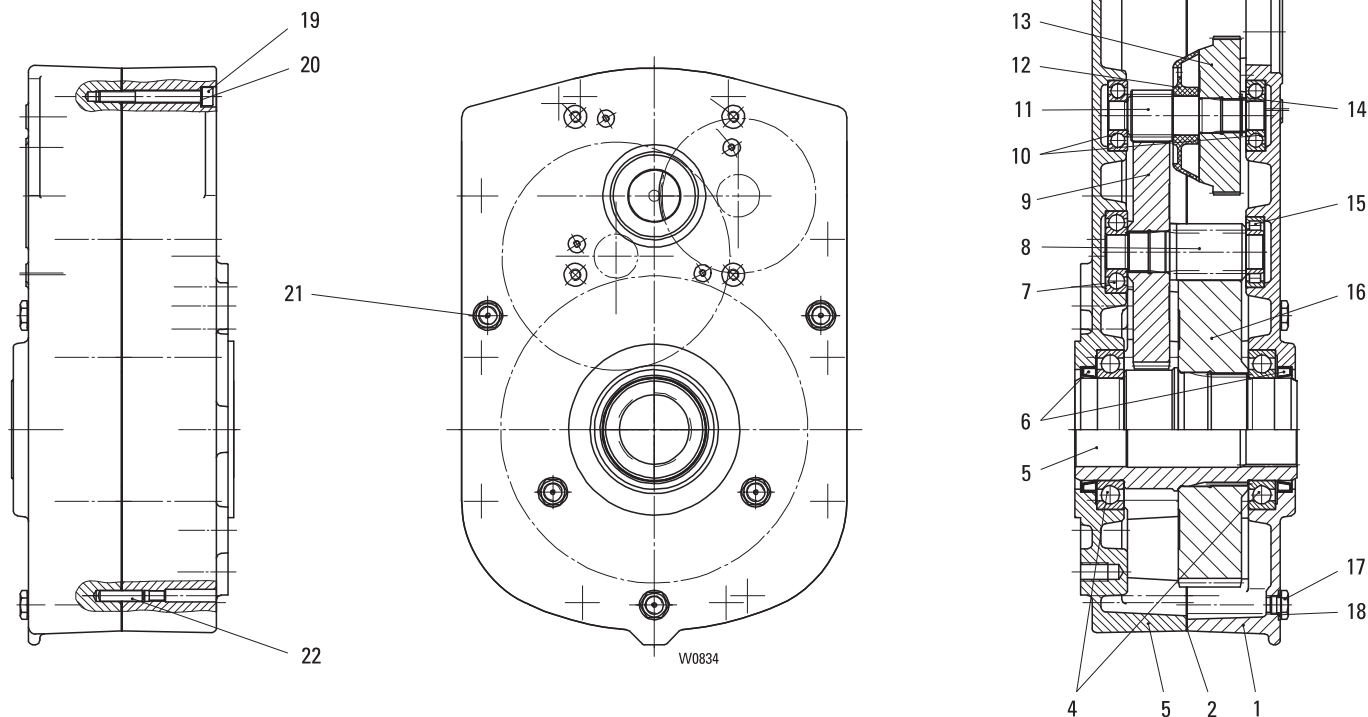

Pos	Teil-Nummer Part-Number	Stück Piece	Beschreibung Description	Benennung Designation	
	16 270 09 30 0	1	SA-. 67 46 (Pos.1-22)	Getriebe Gear	
	16 270 10 30 0	1	SA-. 67 44 (Pos.1-22)		
	16 270 11 30 0	1	SA-. 67 42 (Pos.1-22)		
	16 270 12 30 0	1	SA-. 67 40 (Pos.1-22)		
	16 270 13 30 0	1	SA-. 67 38 (Pos.1-22)		
	16 270 14 30 0	1	SA-. 67 36 (Pos.1-22)		
	16 270 15 30 0	1	SA-. 67 34 (Pos.1-22)		
	16 270 16 30 0	1	SA-. 67 32 (Pos.1-22)		
	16 270 17 30 0	1	SA-. 67 30 (Pos.1-22)		
	16 270 18 30 0	1	SA-. 67 28 (Pos.1-22)		
	16 270 19 30 0	1	SA-. 67 26 (Pos.1-22)		
1	16 277 02 01 0	1			Getriebegehäuse Gear box
2	34 255 00 95 0	1			Dichtung Seal
3	16 277 02 02 0	1		Getriebedeckel Gear cover	
4	560 113 0	2	16018-C3 DIN 625	Rillenkugellager Grooved ball bearing	
5	16 277 01 23 0	1		Abtriebswelle Drive shaft	
6	561 806 0	2	A90x110x12 DIN 3760	Wellendichtring Shaft seal	
7	560 168 0	1	6306 DIN 625	Rillenkugellager Grooved ball bearing	
8	16 277 13 19 0	1	SA-. 67 46 z=11	Ritzelwelle Pinion	
		1	SA-. 67 42		
		1	SA-. 67 40		
		1	SA-. 67 36		
		1	SA-. 67 32		
	16 277 14 19 0	1	SA-. 67 28 z=13		
		1	SA-. 67 44		
		1	SA-. 67 38		
		1	SA-. 67 34		
		1	SA-. 67 30		
		1	SA-. 67 26		



**Originalteile**  
**Original parts**  
**SA-D 67**

Pos	Teil-Nummer Part-Number	Stück Piece	Beschreibung Description	Benennung Designation	Designation	
9	16 277 16 11 0	1	SA-. 67 46	z=80	Zahnrad	Toothed wheel
		1	SA-. 67 44			
		1	SA-. 67 40			
		1	SA-. 67 38			
	16 277 15 11 0	1	SA-. 67 42	z=73		
		1	SA-. 67 36			
		1	SA-. 67 34			
		1	SA-. 67 32			
	16 277 14 11 0	1	SA-. 67 32	z=64		
		1	SA-. 67 30			
		1	SA-. 67 28			
		1	SA-. 67 26			
10	560 020 0	2	6305	DIN 625	Rillenkugellager	Grooved ball bearing
11	16 277 10 19 0	1	SA-. 67 46	z=15	Ritzelwelle	Pinion
		1	SA-. 67 44			
		1	SA-. 67 40			
		1	SA-. 67 38			
	16 277 11 19 0	1	SA-. 67 42	z=22		
		1	SA-. 67 36			
		1	SA-. 67 34			
		1	SA-. 67 32			
	16 277 12 19 0	1	SA-. 67 32	z=31		
		1	SA-. 67 30			
		1	SA-. 67 28			
		1	SA-. 67 26			
12	34 255 00 39 0	1			Ölleitring	Oil splash ring
13	16 277 11 11 0	1	SA-. 67 46	z=125	Zahnrad	Toothed wheel
		1	SA-. 67 44			
		1	SA-. 67 42			
		1	SA-. 67 40			
	16 277 12 11 0	1	SA-. 67 40	z=80		
		1	SA-. 67 38			
		1	SA-. 67 36			
		1	SA-. 67 34			
	16 277 13 11 0	1	SA-. 67 32	z=51		
		1	SA-. 67 30			
		1	SA-. 67 28			
		1	SA-. 67 26			
14	506 812 0	1	29x1,5	DIN 471	Sicherungsring	Circlip
15	560 824 0	1	NJ 206 EC	DIN 5412	Zyl-Rollenlager	Roller bearing
16	16 277 18 11 0	1	SA-. 67 46	z=78	Zahnrad	Toothed wheel
		1	SA-. 67 42			
		1	SA-. 67 40			
		1	SA-. 67 36			
	16 277 17 11 0	1	SA-. 67 32	z=75		
		1	SA-. 67 28			
		1	SA-. 67 44			
		1	SA-. 67 38			
	16 277 17 11 0	1	SA-. 67 34	z=75		
		1	SA-. 67 30			
		1	SA-. 67 30			
		1	SA-. 67 26			
17	503 912 0	4	AM16x1,5	DIN 7604	Verschlussschraube	Screw plug
18	515 004 0	5	C16x20	DIN 7603	Dichtring	Sealing ring
19	500 237 0	10	M10x90	ISO4762-8.8	Zyl-Schraube	Socket head cap screw
20	506 904 0	10	10	DIN 7980	Federring	Spring washer
21	32 250 00 57 0	1			Verschlussschraube	Screw plug
22	504 969 0	2	10m6x40	ISO 2338	Zyl-Stift	Dowel pin

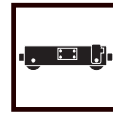

**Drehmomentstütze/Torque support**

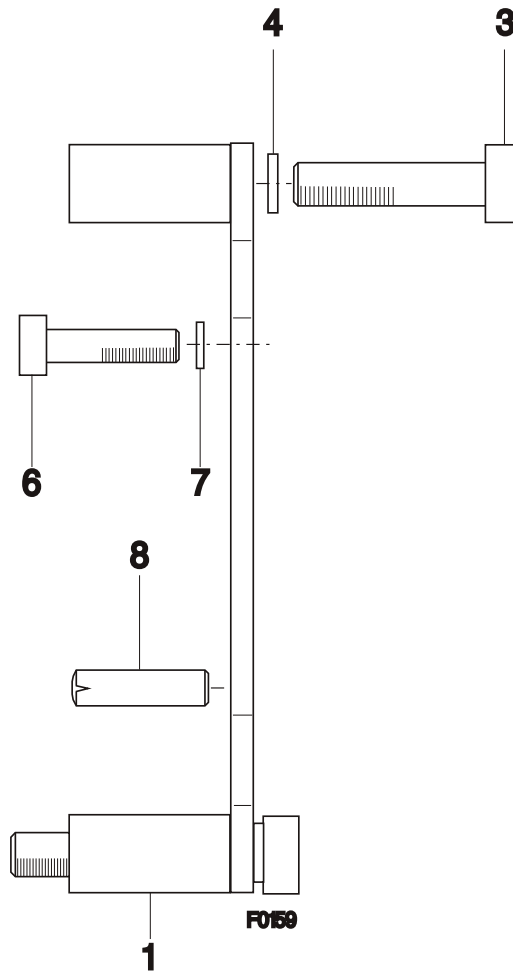

Pos	Teil-Nummer Part-Number	Stück Piece	Beschreibung Description	Benennung	Designation
1	21 270 01 22 0	1	SF1 (Pos.3-8)	Drehmomentstütze	Torque support
3	500 980 0	4	M8x45 DIN 912-8.8	Zyl-Schraube	Socket head cap screw
4	506 839 0	4	S8	Sicherungsscheibe	Locking disc
6	500 144 0	4	M8x16 DIN 912-8.8	Zyl-Schraube	Socket head screw
7	506 839 0	4	S8	Sicherungsscheibe	Locking disc
8	504 960 0	2	8m6x24 DIN 7	Zyl-Stift	Pin



Originalteile  
Original parts  
SF 25

## Drehmomentstütze/Torque support

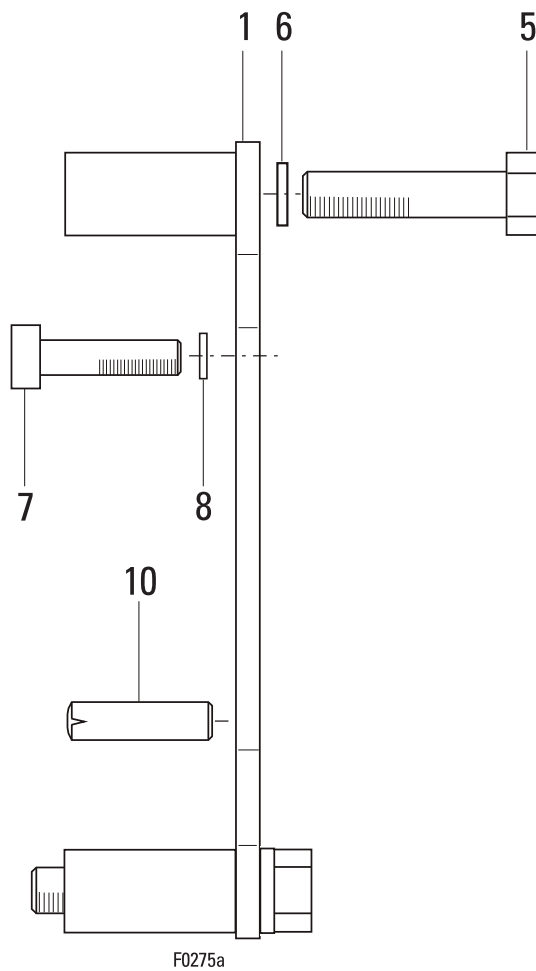

Pos	Teil-Nummer Part-Number	Stück Piece	Beschreibung Description	Benennung	Designation
1	22 270 01 22 0	1	SF 25 (Pos.5-10)	Drehmomentstütze	Torque support
5	500 205 0	4	M12x50 ISO 4014	Skt-Schraube	Haxon head cap screw
6	507 104 0	4	SKM12	Sperrkantscheibe	Lock washer
7	500 234 0	4	M8x25 8.8 ISO 4762	Zyl-Schraube	Socket head screw
8	506 839 0	4	S8	Sicherungsscheibe	Locking disc
10	504 960 0	2	8m6x24 DIN 7	Zyl-Stift	Pin

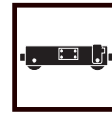

**Drehmomentstütze/Torque support**

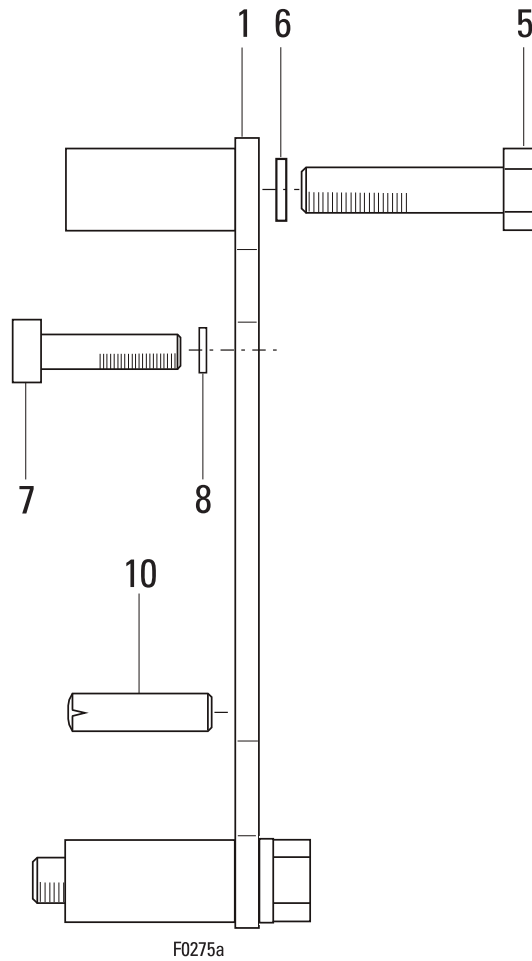

F0275a

Pos	Teil-Nummer Part-Number	Stück Piece	Beschreibung Description	Benennung	Designation
1	23 270 06 22 0	1	(Pos.5-10)	Dehmomentstütze	Torque support
5	500 208 0	4	M12x65 ISO 4014-8.8	Skt-Schraube	Hexagon head cap screw
6	507 104 0	4	SKM 12 ISO 4762	Sperrkantscheibe	Lock washer
7	500 148 0	4	M10x25 8.8	Zyl-Schraube	Socket head screw
8	506 840 0	4	S10 DIN 7	Sicherungsscheibe	Locking disc
10	504 835 0	2	10m6x28	Zyl-Stift	Pin



Originalteile  
Original parts  
SA-D 57

## Drehmomentstütze/Torque support

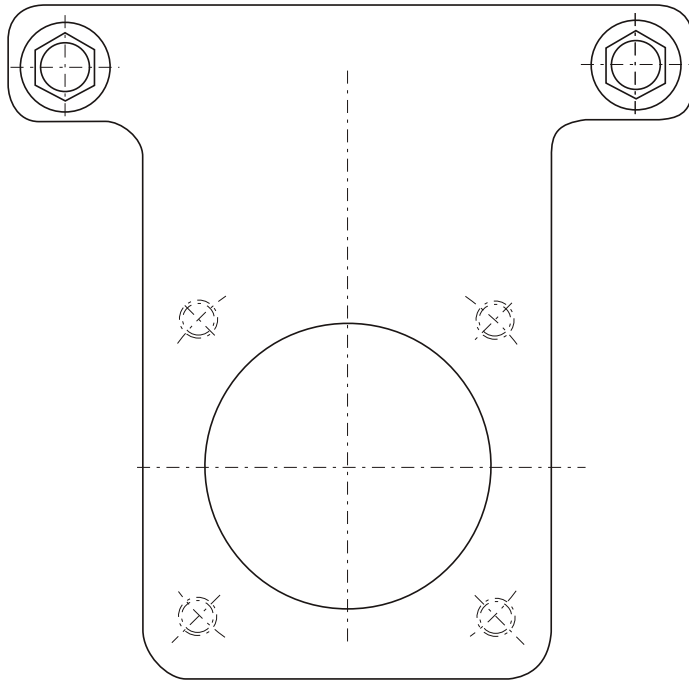

W0836

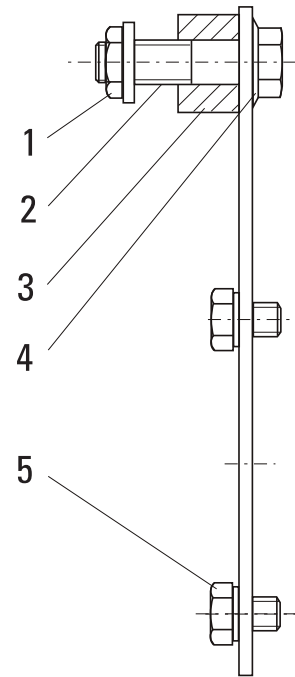

Pos	Teil-Nummer Part-Number	Stück Piece	Beschreibung Description	Benennung	Designation
1	15 270 03 22 0	1	SA-. 5 (Pos.1-5)	Drehmomentstütze	Torque support
	15 270 04 22 0	1	SA-. 5 (FE-A315) (Pos.1-5)		
	15 270 05 22 0	1	SA-. 5 (FE-A400) (Pos.1-5)		
2	507 840 0	2	M12	Sicherungsmutter Skt-Schraube	Locknut Heyagon head cap screw
	500 356 0	2	M12x70 ISO 4014-8.8		
3	500 357 0	2	M12x90 (FE-A315) ISO 4014-8.8	Buchse Distanzstück Distanzstück	Bushing Bushing Bushing
	500 933 0	2	M12x80 (FE-A400) ISO 4014-8.8		
	15 277 02 52 0	2	30/13/26 (FE-A315)		
4	16 277 01 55 0	2	(FE-A400)	Sperrkantscheibe	Disc
	16 277 00 55 0	2	(FE-A400)		
5	507 104 0	2	SKM 12	Sicherungsschraube	Safety bolt
	501 122 0	4	M12x25-10		



**Drehmomentstütze/Torque support**

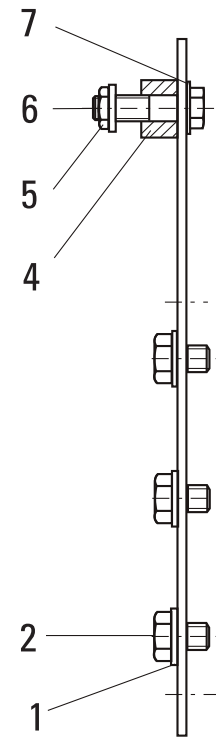
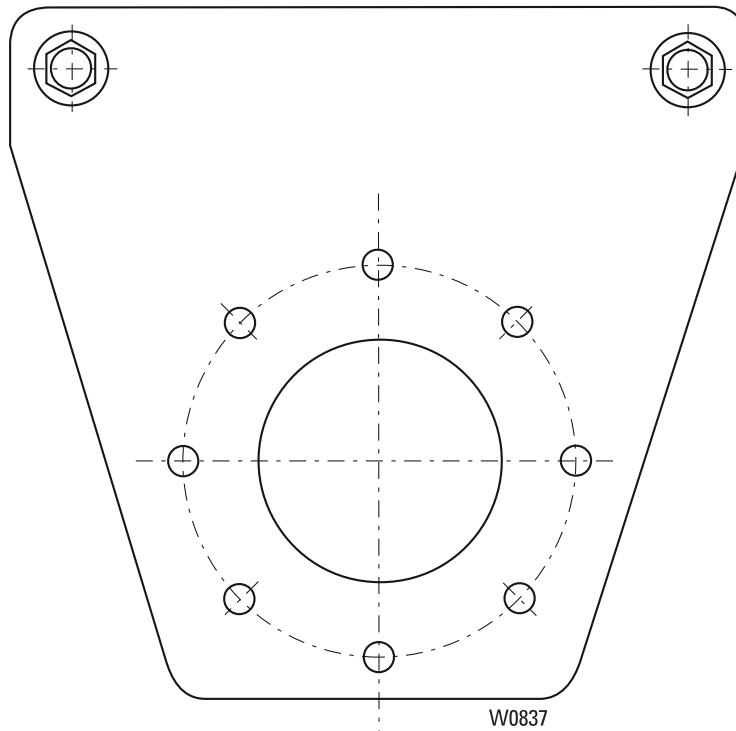

Pos	Teil-Nummer Part-Number	Stück Piece	Beschreibung Description	Benennung	Designation
	16 270 00 22 0	1	(Pos.1-7)	Drehmomentstütze	Torque support
1	562 953 0	6	16 DIN 6797	Spannscheibe	Disc
2	500 337 0	6	M16x30 ISO 4017-8.8	Skt-Schraube	Hexagon head cap screw
4	16 277 01 52 0	2	40/17/22	Buchse	Bushing
5	507 841 0	2	M16	Sicherungsmutter	Locknut
6	500 213 0	2	M16x70 ISO 4014-8.8	Skt-Schraube	Hexagon head cap screw
7	562 953 0	2	16 DIN 6797	Spannscheibe	Disc

Россия ООО "КранШталь" 109451, г.Москва, ул. Верхние поля, д.28  
тел./факс: +7 495 2253788 +7 495 9214517 info@stahlcranes.ru

→ [www.kranstahl.ru](http://www.kranstahl.ru)  
→ [www.tali-market.ru](http://www.tali-market.ru)

→ [www.servis-kran.ru](http://www.servis-kran.ru)  
→ [www.stahlcranes.ru](http://www.stahlcranes.ru)



*Partner of*

