

КранШталь



SH 6



Explosiongeschützte Seilzüge _

↘ DE

Originalteileliste

Explosion-Protected Wire Rope Hoists _

↘ EN

Original parts list

⊕ II 2 G (ATEX) - Zone 1

⊕ II 2 D (ATEX) - Zone 21

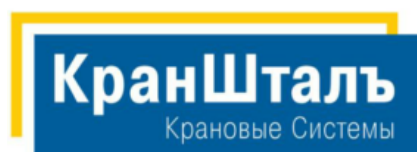

<http://kranstahl.ru>
info@kranstahl.ru

Partner of



+7 (495) 225-37-88



Notizen
Notice

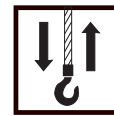

Hubmotor 4	Hoist motor 4
Zwischengetriebe 6	Intermediate gear 6
Getriebe 7	Gear 7
Seiltrommel 9	Rope drum 9
Seilaufhängung 11	Rope suspension 11
Hakenflasche 13	Bottom hook block 13
Gerätekasten 17	Control panel 17
Steuerung 18	Control 18
Steuergerät 18	Control pendant 18
Fahrwerke 19	Trolleys 19
Fahrantriebe 22	Travel drives 22
Drehmomentstütze 38	Torque support 38

Austausch und Reparaturen nur von geschultem Personal ausführen lassen.
Die Angaben in der Spalte "Benennung" dienen nur internen Vorgängen.

Replacement and repairs may only be carried out by trained personnel.
The information in the column "Designation" is only for internal use.

Bitte immer die Fabrik-Nr. des Hebezeuges angeben.

Please always state hoist serial number.

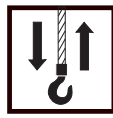

Originalteile
Original parts
SH 6 ex

A6 ex

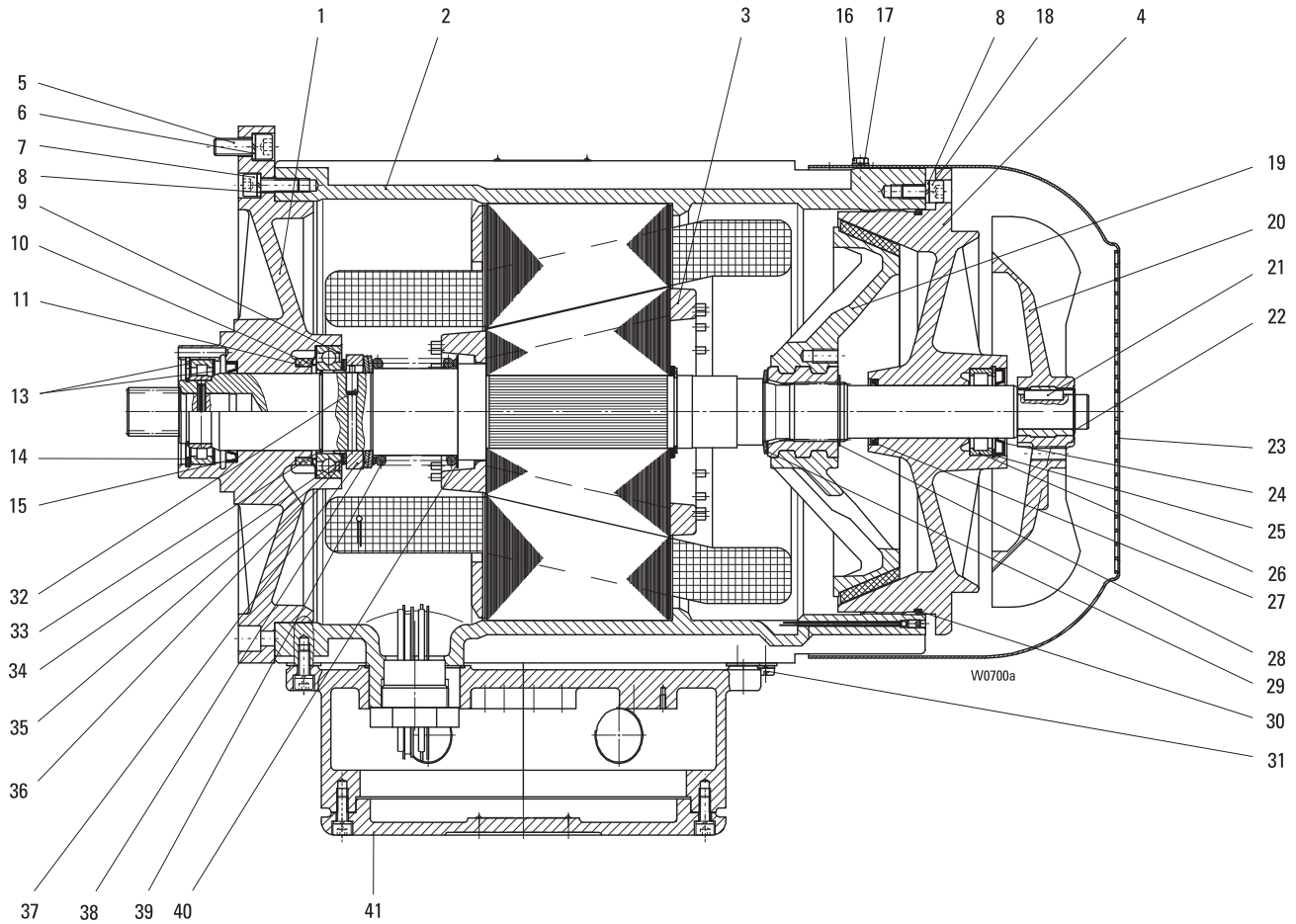

Pos	Teil-Nummer Part-Number	Stück Piece	Beschreibung Description	Benennung Designation	Designation
	46 330 28 11 0	1	2/12A6 IIB *1 1)	Motor	Motor
	46 330 29 11 0	1	2/12A6 IIC *1 1)		
1	46 331 25 03 0	1	IIB	Motorflansch	Motor flange
	46 331 26 03 0	1	IIC		
2	46 330 74 12 9	1	2/12A6 IIC 1)	Stator	Stator
3	46 330 56 13 0	1	2) 2)	Rotor	Rotor
	46 330 57 13 0	1	3) 3)		
4	46 330 53 37 0	1	IIB (Pos. 24-27,30)	Motordeckel	Motor cover
	46 330 54 37 0	1	IIC (Pos. 24-27,30)		
	46 330 55 37 0	1	IIC 4) (Pos. 24-27,30)		
5	500 151 0	8	M12x30 ISO 4762-8.8	Zyl.-Schraube	Socket head cap screw
6	506 905 0	8	12 DIN 7980	Federring	Spring washer
7	500 236 0	8	M10x30 DIN 912 -8.8	Zyl.Schraube	Socket head cap screw
8	506 904 0	12	10 DIN 7980	Federring	Spring washer
9	560 841 0	1	6012-ZR DIN 625	Rillenkugellager	Grooved ball bearing
10	561 890 0	1	6012 JKS	Nilosring	Nilos ring
11	46 331 20 95 0	1		Dichtring	Sealing ring
13	46 331 00 52 0	2		Scheibe	Disc
14	506 379 0	1	75x2,5 DIN 472	Sicherungsring	Locking ring
15	561 832 0	1	55x72x8	Wellendichtring	Shaft seal
16	500 313 0	4	M6x8 ISO 4017	Skt-Schraube	Hexagon head cap screw
17	506 043 0	4	A6 DIN 127	Federring	Spring washer
18	500 147 0	4	M10x20 ISO 4762 -8.8	Zyl-Schraube	Socket head cap screw
19	46 330 20 18 0	1		Bremsscheibe	Brake disc
20	46 331 20 15 0	1		Lüfterrad	Fan wheel
21	537 048 0	1	A8x7x28 DIN 6885	Passfeder	Feather key

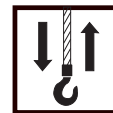

Pos	Teil-Nummer Part-Number	Stück Piece	Beschreibung Description	Benennung	Designation
22	506 097 0	1	25x1,2 DIN 471	Sicherungsring	Locking ring
23	46 331 03 40 0	1		Lüfterhaube	Fan cowling
24	1	A38x62x7 DIN 3760	Wellendichtring	Shaft seal
25	1	62x2 DIN 472	Sicherungsring	Circlip
26	1	NJ 206 EC DIN 5412	Zyl.-Rollenlager	Roller bearing
27	1	37x47x4 DIN 3760	Wellendichtring	Shaft seal
28	506 248 0	1	42x1,75 DIN 471	Sicherungsring	Circlip
29	46 331 20 14 0	1	60x42,5x3,725x2,5	Tellerfeder	Belleville spring washer
30	515 979 0	1	265x4	Runddichtring	Round sealing ring
31	46 330 71 81 0	1		Erdungsklemme	earth clamp
32	46 331 03 92 0	1		Stift	Pin
33	506 145 0	1	SW55	Spreng ring	Spring ring
34	46 331 03 52 0	1		Scheibe	Disc
35	46 331 04 52 0	1		Scheibe	Disc
36	506 911 0	1	S60x75x3	Stützscheibe	Supporting ring
37	46 331 08 51 0	1		Abstandsring	Sacer ring
38	46 331 01 94 0	1		Tellerfeder	Belleville spring washer
39	46 331 89 94 0	1		Druckfeder	Pressure spring
40	506 567 0	1	63x80x1 DIN 988	Passscheibe	Adjusting washer
41	04 330 81 97 0	1		Kastendeckel	Box cover

*1 Bitte angeben: Abtriebswelle Linksschräg: rechtsschräg; geradzahnt
toothed

- 1) Bitte Betriebsspannung und Frequenz angeben.
- 2) Ausführung linksschräg
- 3) Ausführung rechtsschräg
- 4) hartverchromt

*1 Please state: with output shaft left-handed; right-handed; spur-

- 1) Please state operating voltage and frequency.
- 2) Left-hand design
- 3) Righthand design
- 4) Hard chrome plated



Originalteile
Original parts
SH 6 ex

Zwischengetriebe / Intermediate gear

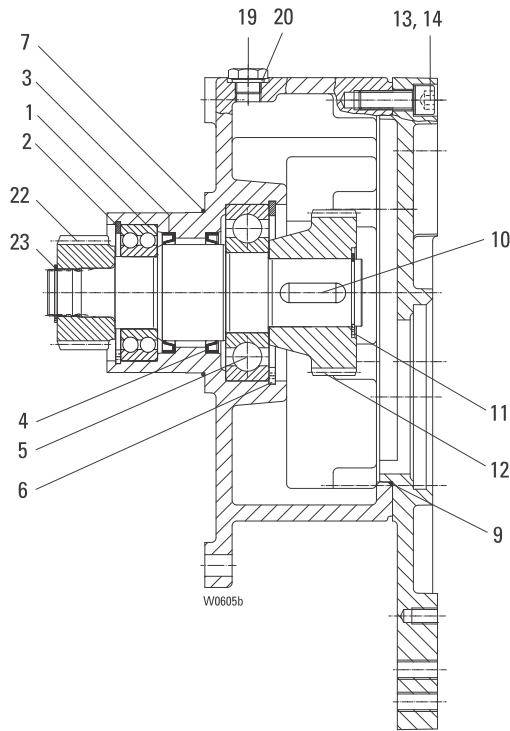

Pos	Teil-Nummer Part-Number	Stück Piece	Beschreibung Description	Benennung	Designation
	25 270 18 30 0	1	SH60..-15	Zwischengetriebe	Intermediate gear
		1	SH60..-18		
	25 270 19 30 0	1	SH60..-9		
		1	SH60..-12		
1	560 166 0	1	4209A	DIN 625	Rillerkugellager Grooved ball bearing
2	506 109 0	1	85x3	DIN 471	Sicherungsring Locking ring
3	561 109 0	1	60x75x8 NB	DIN 3760	Wellendichtring Shaft seal
4	561 109 0	1	60x75x8 NB	DIN 3760	Wellendichtring Shaft seal
5	560 037 0	1	6309	DIN 625	Rillerkugellager Grooved ball bearing
6	506 264 0	1	100x3	DIN 472	Sicherungsring Locking ring
7	515 028 0	1	95x2	NB 70	Runddichtring Round sealing ring
9	515 957 0	1	230x2	NB 70	Runddichtring Round sealing ring
10	537 961 0	1	B12x8x28		Passfeder Feather key
11	506 248 0	1	42x1,75	DIN 471	Sicherungsring Locking ring
12	25 273 25 11 0	1			Zahnrad Gear wheel
13	500 183 0	8	M12x35	ISO 4762	Zyl-Schraube Socket head cap screw
14	506 841 0	8	S 12	vz	Sicherungsscheibe Lock washer
19	503 011 0	4	M16x1,5		Verschlussschraube Locking bolt
20	515 004 0	4	C16x20		Dichtring Sealing ring
22	25 273 16 11 0	1	SH60..-15		Zahnrad Gear wheel
		1	SH60..-18		
	25 273 17 11 0	1	SH60..-9		
		1	SH60..-12		
23	506 812 0	1	29x1,5	DIN 471	Sicherungsring Locking ring

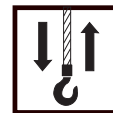

Getriebe/gear

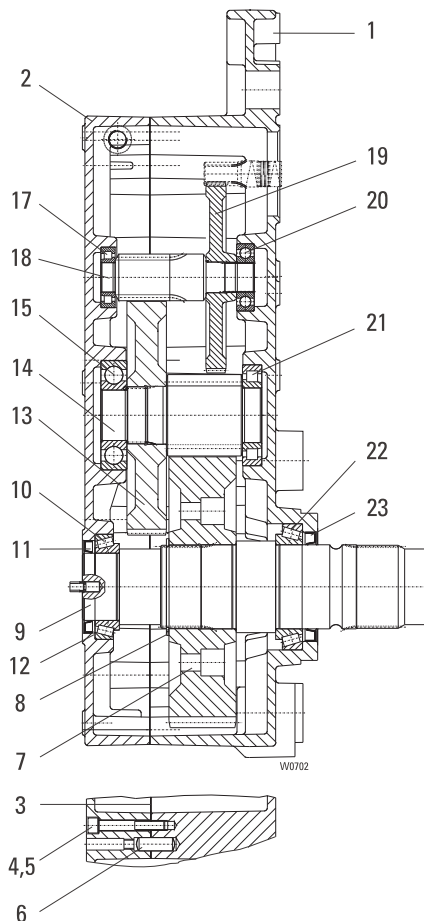

Pos	Teil-Nummer Part-Number	Stück Piece	Beschreibung Description	Benennung	Designation
	26 270 02 30 0	1	SH 60..-6	Getriebe	Gear
	26 270 03 30 0	1	SH 60..7		
	26 270 04 30 0	1	SH 60..-9		
	26 270 05 30 0	1	SH 60..-12		
	26 270 06 30 0	1	SH 60..-15		
	26 270 07 30 0	1	SH 60..-18		
	26 270 08 30 0				
1	26 273 01 01 0	1		Getriebegehäuse	Gear box
2	26 273 01 02 0	1		Getriebedeckel	Gear cap
3	26 273 00 95 0	1		Dichtung	Seal
4	500 383 0	12	M12x80	Zyl-Schraube	Socket head cap screw
5	506 841 0	12	S12	Sicherungsscheibe	Lock washer
6	504 951 0	2	16m6x40	Zyl-Stift	Dowel pin
7	26 273 00 11 0	1		Zahnrad	Gear wheel
8	506 253 0	1	100x3	Sicherungsring	Retainer ring
9	26 270 00 38 0	1		Antriebswelle	Drive shaft
10	560 070 0	1	320 16X	Kegelrollenlager	Bearing
11	561 110 0	1	80x110x10	Wellendichtring	Shaft seal
12	506 195 0	1	110x125x0,3	Passscheibe	Adjusting washer
	506 196 0	1	110x125x0,2		

Ohne Getriebeöl: Erforderliche Menge siehe Betriebsanleitung
1) nach Bedarf

Without gear oil: amount required see operating instruction.
1) As required

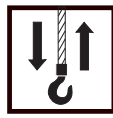

Getriebe/gear

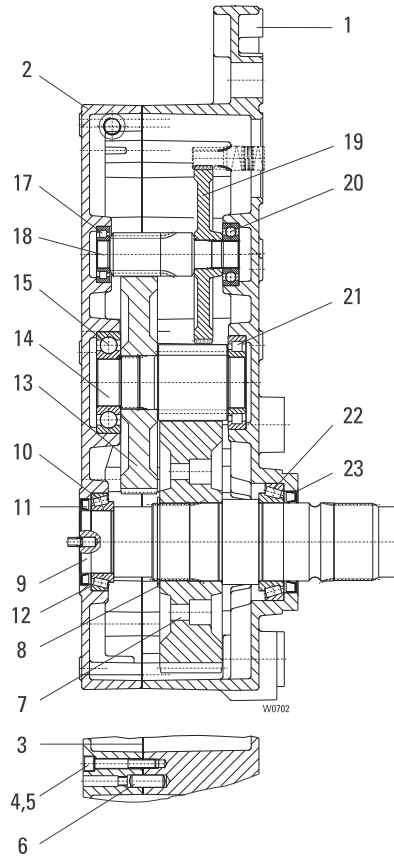

Pos	Teil-Nummer Part-Number	Stück Piece	Beschreibung Description	Benennung Designation	Designation	
13	26 273 03 11 0	1	SH 60..-6	z=88	Zahnrad	Gear wheel
		1	SH 60..-9			
		1	SH 60..-15			
		1	SH 60..-23			
	26 273 02 11 0	1	SH 60..-7	z=65		
		1	SH 60..-12			
		1	SH 60..-18			
14	26 273 02 19 0	1		z=13	Ritzelwelle	Pinion shaft
15	560 080 0	1	6313	DIN 625	Rillenkugellager	Grooved ball bearing
17	560 135 0	1	NJ 207 EC	DIN 5412	Zyl-Rollenlager	Cylindrical roller bearing
18	26 273 03 19 0	1	SH 60..-6	z=15	Ritzelwelle	Pinion shaft
		1	SH 60..-9			
		1	SH 60..-15			
		1	SH 60..-23			
	26 273 01 19 0	1	SH 60..-7	z=14		
		1	SH 60..-12			
		1	SH 60..-18			
19	25 273 03 11 0	1	SH 60..-6	z=90	Zahnrad	Gear wheel
	25 273 01 11 0	1	SH 60..-7			
		1	SH 60..-15	z=64		
	25 273 02 11 0	1	SH 60..-18			
		1	SH 60..-9	z=71		
	25 273 19 11 0	1	SH 60..-12	z=55		
20	560 061 0	1	6307	DIN 625	Rillenkugellager	Grooved ball bearing
		1				
21	560 121 0	1	NJ 213 E	DIN 5412	Zyl-Rollenlager	Cylindrical roller bearing
22	560 838 0	1	320 20X	DIN 720	Kegelrollenlager	Bearing
23	561 845 0	1	100x130x13	NB	Wellendichtring	Shaft seal

Ohne Getriebeöl: Erforderliche Menge siehe Betriebsanleitung
1) nach Bedarf

Without gear oil: amount required see operating instruction.
1) As required

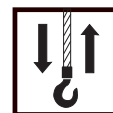

Seiltrommel/rope drum

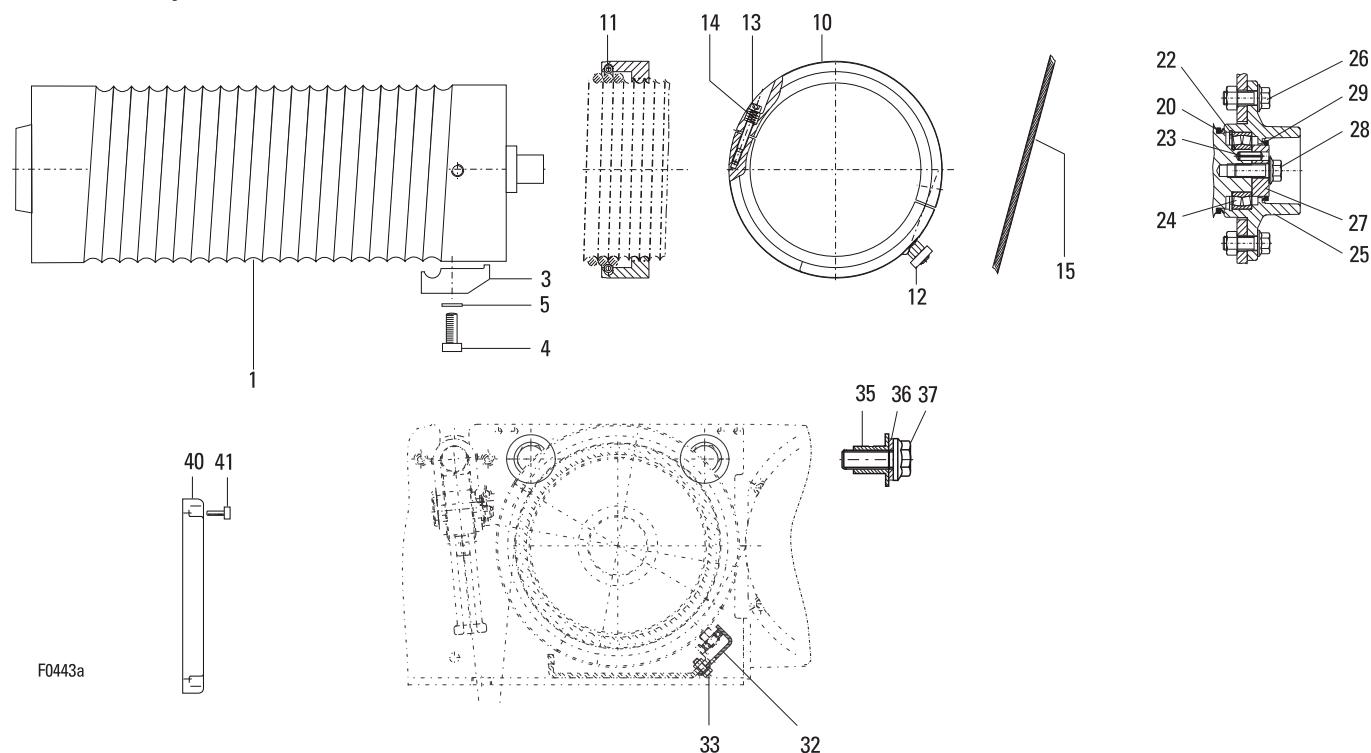

F0443a

Pos	Teil-Nummer Part-Number	Stück Piece	Beschreibung Description			Benennung	Designation
1	06 430 00 40 0	1	D20	L2	/1	Seiltrommel	Rope drum
	06 430 01 40 0	1	D20	L3	/1		
	06 430 02 40 0	1	D20	L4	/1		
	06 430 03 40 0	1	D20	L5	/1		
	06 430 04 40 0	1	D16	L2	/1		
	06 430 05 40 0	1	D16	L3	/1		
	06 430 06 40 0	1	D16	L4	/1		
	06 430 07 40 0	1	D16	L5	/1		
	06 430 08 40 0	1	D14	L2	/1		
	06 430 09 40 0	1	D14	L3	/1		
	06 430 10 40 0	1	D14	L4	/1		
	06 430 11 40 0	1	D14	L5	/1		
	06 430 12 40 0	1	D12,5	L2	/1		
	06 430 13 40 0	1	D12,5	L3	/1		
	06 430 14 40 0	1	D12,5	L4	/1		
06 430 15 40 0	1	D12,5	L5	/1			
1	06 430 16 40 0	1	D12,5	L2	/2-	Seiltrommel	Rope drum
	06 430 17 40 0	1	D12,5	L3	/2-		
	06 430 18 40 0	1	D12,5	L4	/2-		
	06 430 19 40 0	1	D12,5	L5	/2-		
3	46 330 00 46 0	4	D20	(Pos.4+5)	Klemmplatte Zyl-Schraube Sicherungsscheibe	Clamping plate Socket head cap screw Locking disc	
4	500 152 0	4	M16x35	DIN 912-8.8			
5	507 001 0	4	S 16				
3	06 430 00 46 0	4	D16	(Pos.4+5)	Klemmplatte Zyl-Schraube Sicherungsscheibe	Clamping plate Socket head cap screw Locking disc	
4	500 812 0	4	M16x35	DIN 6912-8.8			
5	507 001 0	4	S 16				
3	05 430 00 46 0	4	D12,5	(Pos.4+5)	Klemmplatte Zyl-Schraube Sicherungsscheibe	Clamping plate Socket head cap screw Locking disc	
4	500 850 0	4	M12x25	DIN 6912-8.8			
5	506 841 0	4	S 12				



Originalteile
Original parts
SH 6 ex

Seiltrommel/rope drum

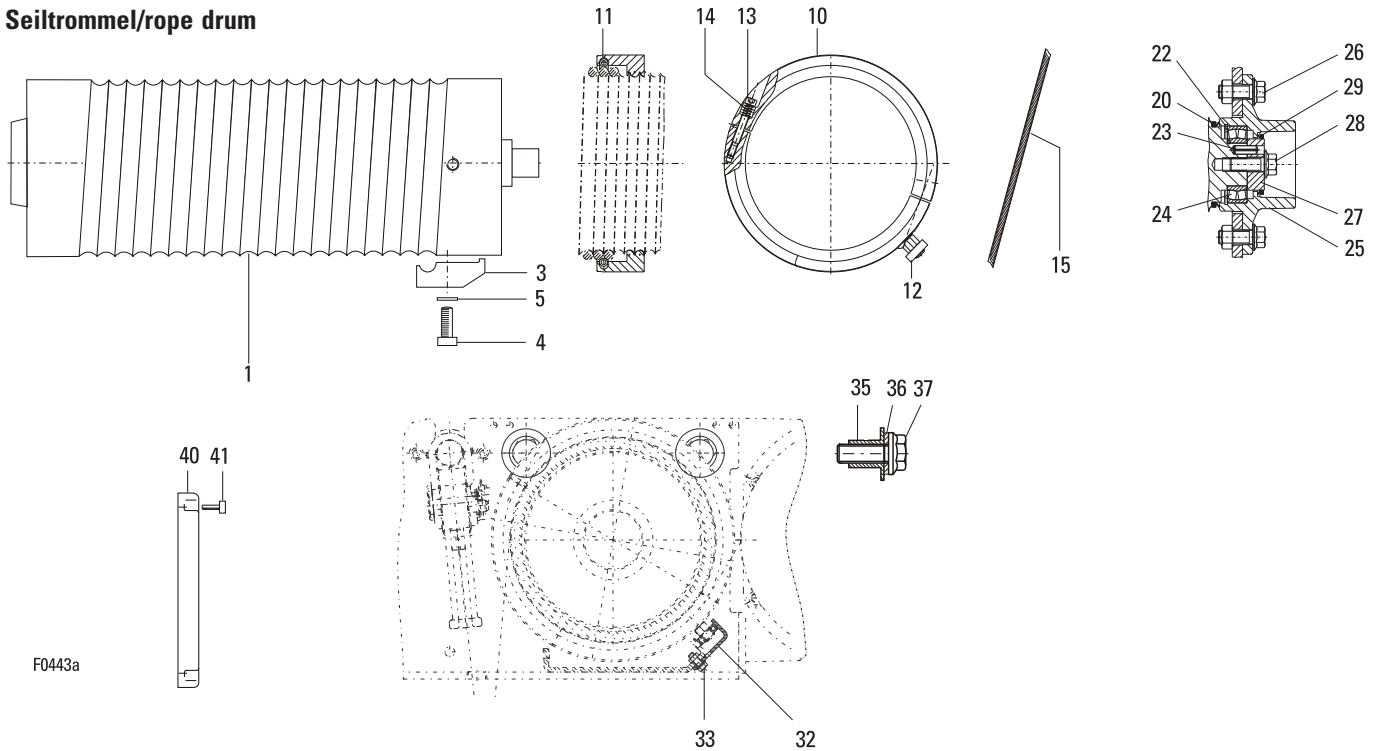

F0443a

Pos	Teil-Nummer Part-Number	Stück Piece	Beschreibung Description		Benennung	Designation
10	06 430 03 43 0	1	D20	/1	(Pos.11-14)	Seilführungsring Rope guide
	06 430 02 43 0	1	D16	/1	(Pos.11-14)	
	06 430 01 43 0	1	D14	/1	(Pos.11-14)	
	06 430 00 43 0	1	D12,5	/2-	1) (Pos.11-14)	
	06 430 04 43 0	1	D12,5	/2-	2) (Pos.11-14)	
11	06 434 00 94 0	1				Zugfeder Tension spring
12	06 430 01 47 0	1				Führungsstück Guide part
13	24 334 01 90 0	2				Schraube Screw
14	50 334 01 94 0	2				Druckfeder Pressure spring
15					3)	Drahtseil Wire rope
20	518 066 0	1				Dichtring Sealing ring
22	560 079 0	1	222 10 E		DIN 1473	Pendelrollenlager Pendulum roller bearing
23	504 837 0	1	10x28			Kerbstift Dowel pin
24	506 194 0	1	90x3 V			Sicherungsring Locking ring
25	06 434 01 57 0	1				Trommellager Drum bearing
26	501 033 0	3	M16x40-10			Sicherungsschraube Safety bolt
27	06 432 02 52 0	1				Haltescheibe Holding disc
28	501 033 0	1	M16x40-10			Sicherungsschraube Safety bolt
29	518 079 0	1				Dichtring Sealing ring
32	06 432 08 05 0	1	L2			Führungsschiene Guide rail
	06 432 09 05 0	1	L3			
	06 432 10 05 0	1	L4			
	06 432 11 05 0	1	L5			
33	501 115 0	9				Sicherungsschraube Safety bolt
35	06 432 00 50 0	1				Bundbuchse Locking disc
36	507 085 0	1	S30			Sicherungsscheibe Hexagon head cap screw
37	500 224 0	1	M30x100			Skt-Schraube
40	05 432 00 40 0	1				Abschlusshaube End cap
41	505 034 0	4	M6x20		DIN 7516	Schraube Screw

4) Siehe Datenblatt
5) Seilzug stehend stationär
6) Seilzug hängend stationär

4) See data sheet
5) Stationary wire rope hoist, upright
6) Stationary wire rope hoist, suspended

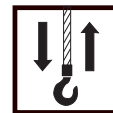

Seilauflhängung/rope suspension

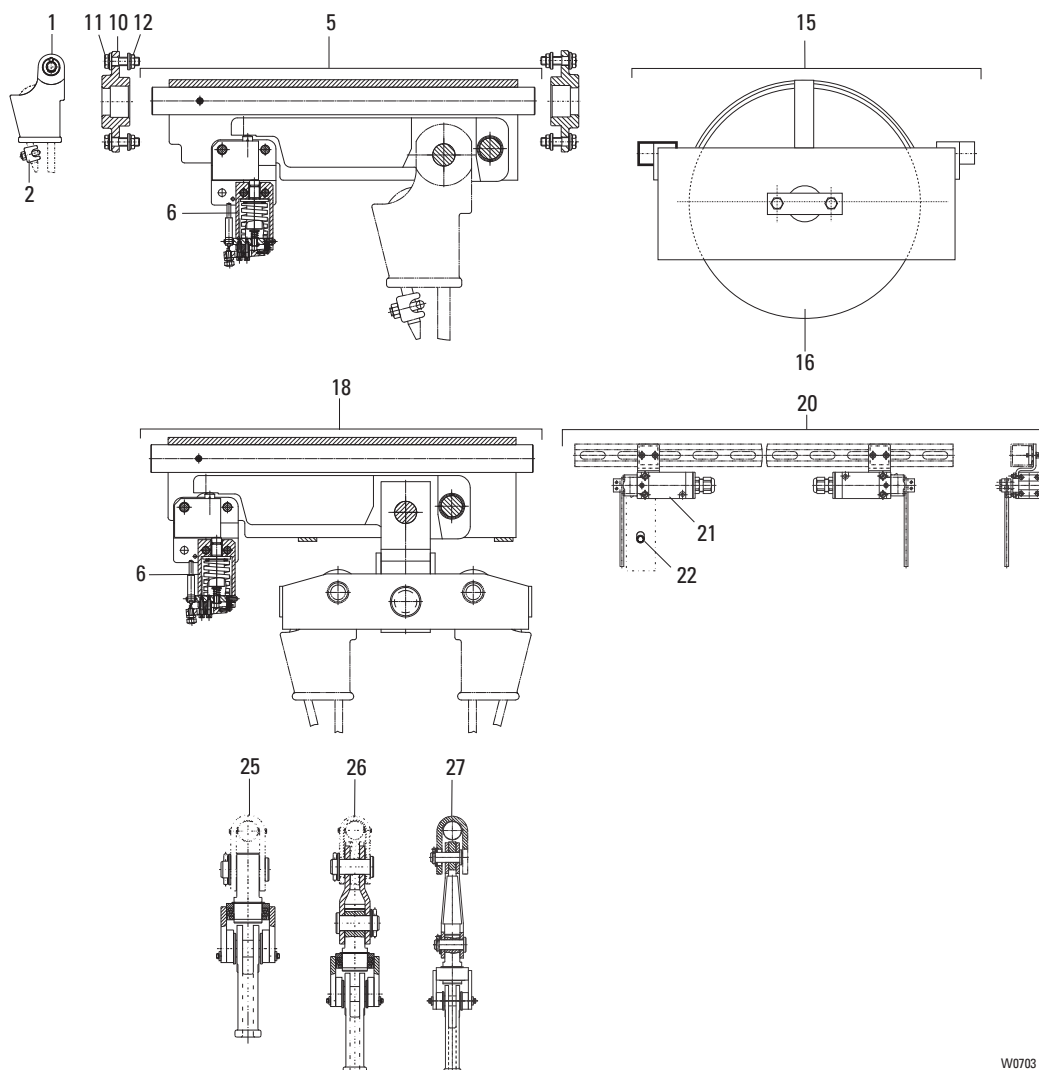

W0703

Pos	Teil-Nummer Part-Number	Stück Piece	Beschreibung Description		Benennung	Designation
1	46 330 00 48 0	1	D-20	/1	SH6	Keilendklemme Clamp
	45 330 04 48 0	1	D-15	/1	SH6	
	06 430 00 48 0	1	D-11,9-12,5	/2-1	SH6/SHR6	
2	517 007 0	1	D-12-12,5		Gr.13 SHR6	Drahtseilklemme Wire rope clamp
	517 008 0	1	D-14-15		Gr.16 SHR6	
	517 801 0	1	D-20		Gr.22 SH6	
5	06 430 00 94 0	1	LMS1	(Pos.6)	1600/4000 [daN]	Lastsensor kompl. Load sensor compl.
	06 430 01 94 0	1	LMS1	(Pos.6)	2000/5000 [daN]	
	06 430 02 94 0	1	LMS1	(Pos.6)	2500/6300 [daN]	
6	05 430 00 84 0	1	LMS1		1600/4000 [daN]	Sensor Sensor
	05 430 01 84 0	1	LMS1		2000/5000 [daN]	
	05 430 02 84 0	1	LMS1		2500/6300 [daN]	
10	06 432 02 12 0		SH6	x)		Lagerstück Bearing pedestal
	06 432 07 12 0		SHR6	x)		
11	501 112 0		M12x40	x)		Sicherungsschraube Safety bolt
12	507 840 0		M12	x)		Sicherungsmutter Locknut
15	46 330 00 27 0	1		(Pos.16)		Umlenkung Deflection cross bar
16	25 330 00 53 0	1				Seilrolle Rope pulley

x) Stückzahl nach Bedarf

x) Quantity as required



Originalteile
Original parts
SH 6 ex

Seilauflhängung/rope suspension

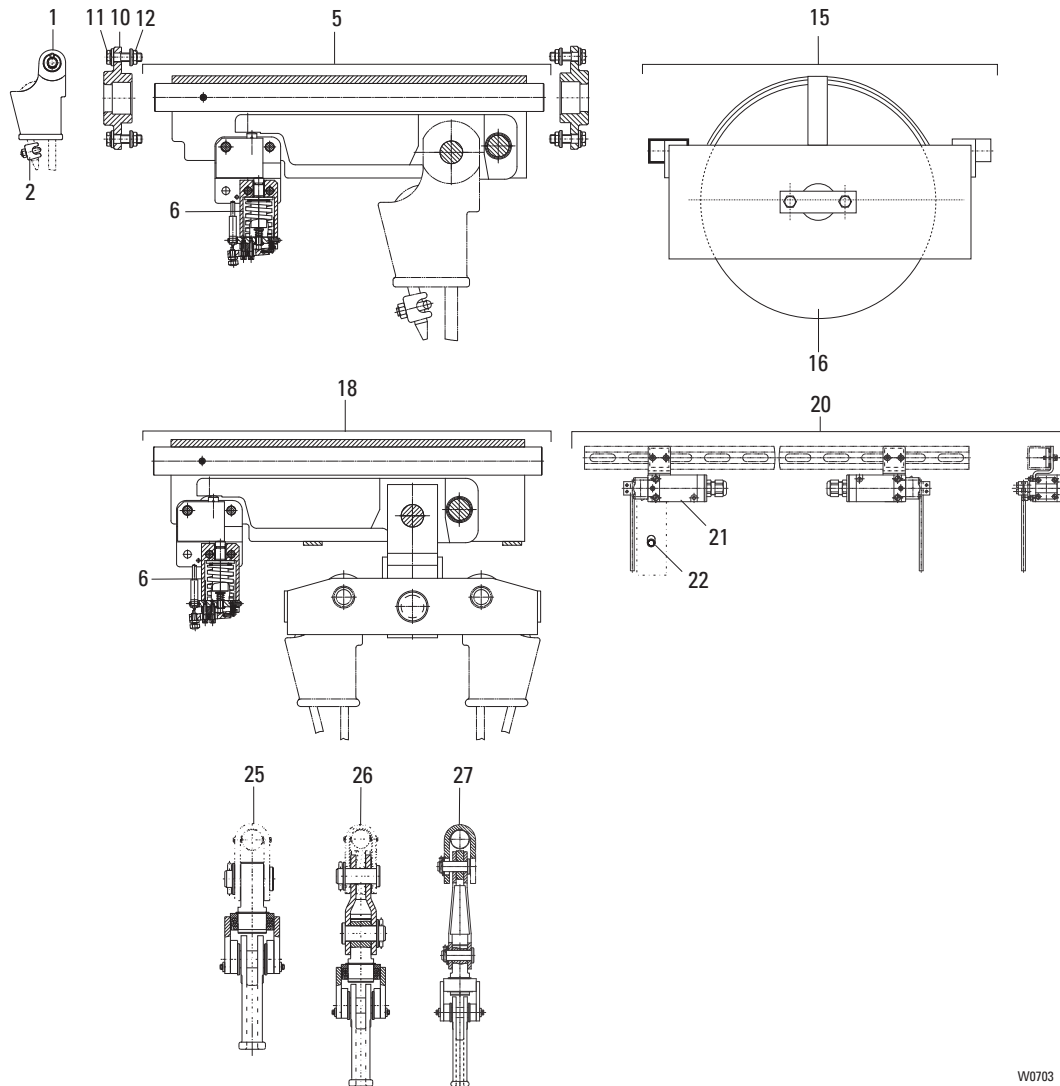

W0703

Pos	Teil-Nummer Part-Number	Stück Piece	Beschreibung Description	Benennung Designation	Designation
18	06 430 04 94 0	1	LMS1 (Pos.6) 1600/4000 [daN]	Lastsensor kompl.	Load sensor compl.
	06 430 05 94 0	1	LMS1 (Pos.6) 2000/5000 [daN]		
	06 430 06 94 0	1	LMS1 (Pos.6) 2500/6300 [daN]		
20	04 430 20 85 0	1		Endschalteranbau	Limit switch attachment
21	04 430 23 85 0	2		Ex-Positionsschalter	Limit switch
22	503 020 0	1	M8x1x80-14Hvz DIN427	Schaftschraube	Screw
25	46 330 22 28 0	1	SH6	Drallfänger	Anti twist device
	46 330 23 28 0	1	SH6		
	06 430 06 28 0	1	SHR6		

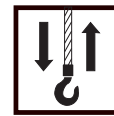

H375-2

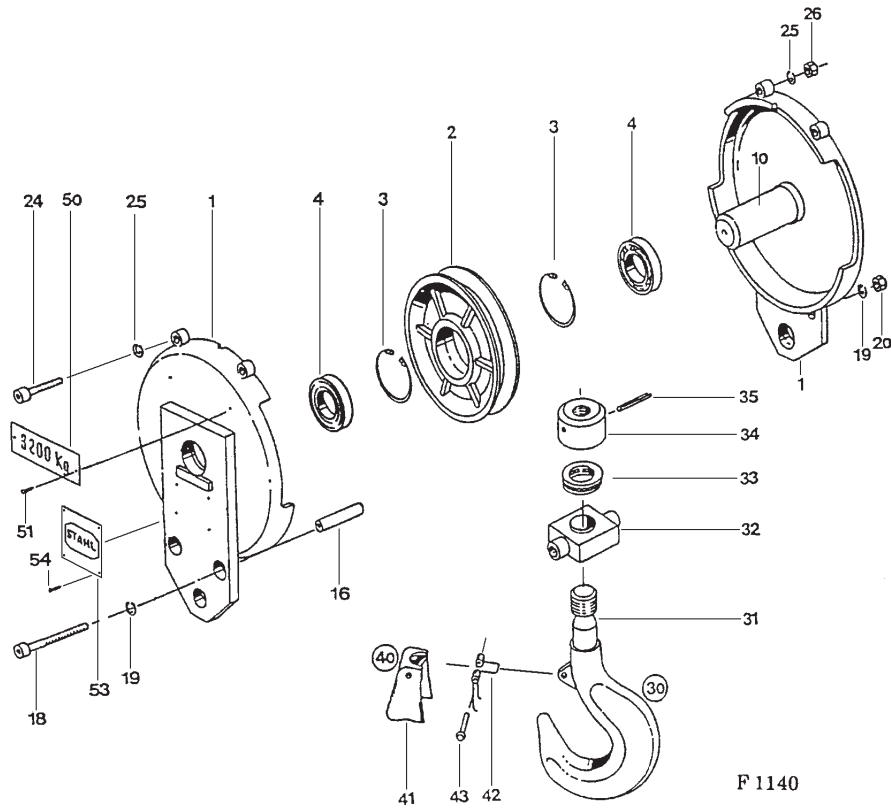

Bitte immer die Fabrik-Nr. des Hebezeuges angeben.

Please always state hoist serial number.



Originalteile
Original parts
SH 6 ex

H227-4

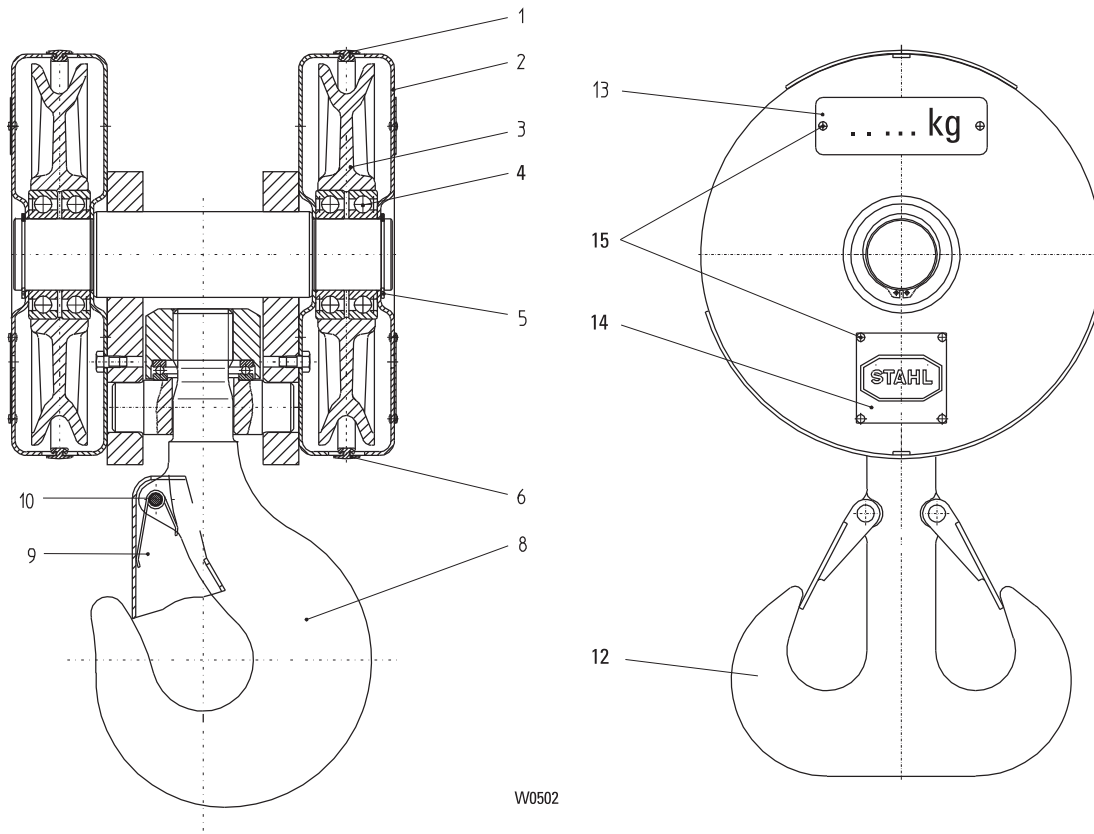

Bitte immer die Fabrik-Nr. des Hebezeuges angeben.

Please always state hoist serial number.

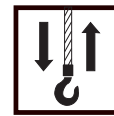

K-A 4. ex

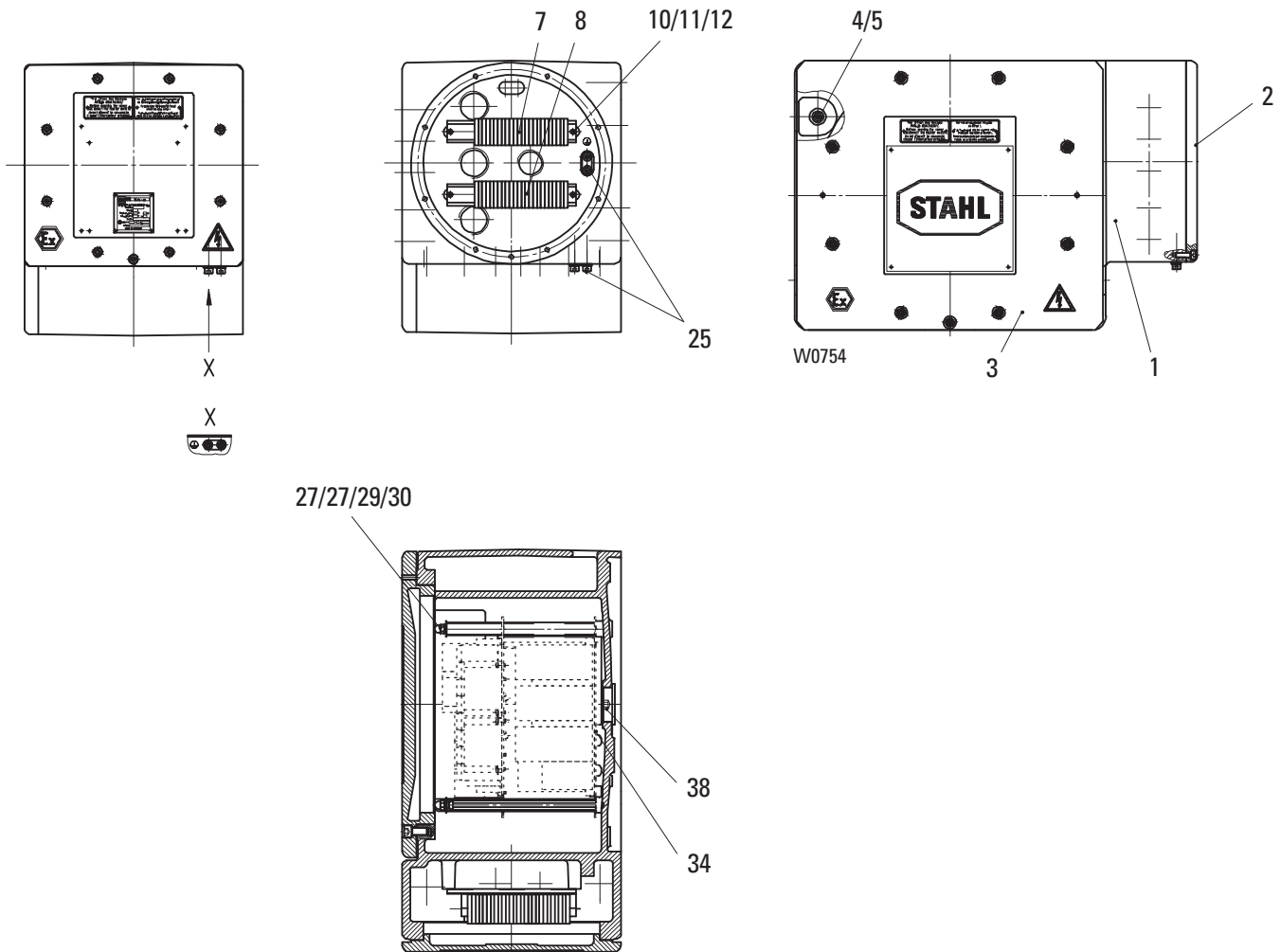

Pos	Teil-Nummer Part-Number	Stück Piece	Beschreibung Description	Benennung	Designation
1	05 439 02 20 0	1	IIC GK-A 4-	Gerätekasten	Terminal box
2	04 430 70 97 0	1	e280	Kastendeckel	Box cover
3	05 430 70 97 0	1	d380 IIB	Kastendeckel	Box cover
	05 430 71 97 0	1	d380 IIC		
4	500 152 0	3	M16x35 ISO 4762	Zyl.-Schraube	Socket head cap screw
5	507 001 0	3	S16	Sicherungsscheibe	Lock washer
7	06 430 42 89 0	1		Klemmleiste	Terminal strip
	06 430 43 89 0	1			
8	06 430 39 89 0	1		Klemmleiste	Terminal strip
	06 430 41 89 0	1			
10	502 051 0	4	M4x8 ISO 1207	Zyl.-Schraube	Socket head cap screw
11	506 374 0	4	4 DIN 7980	Federring	Spring washer
12	506 062 0	4	4,3 DIN 432	Scheibe	Disc
25	46 330 71 81 0	2		Erdungsklemme	Earth clamp
27	46 339 20 92 0	2		Führungsbolzen	Guiding bolt
28	506 859 0	2	8,4 DIN 9021	Scheibe	Disc
29	506 839 0	2	S8	Sicherungsscheibe	Lock washer
30	506 924 0	2	M8 DIN 986	Hutmutter	Cap nut
34	46 330 70 81 0	1		Erdungsklemme	Earth clamp
38	518 242 0	1		Verschlussstopfen	Screw plug

1) Hub.
2) Hub/Fahren

1) Hoist
2) Hoist/Travel



Originalteile
Original parts
SH 6 ex

Standard -Steuerung / standard control
400V/50Hz

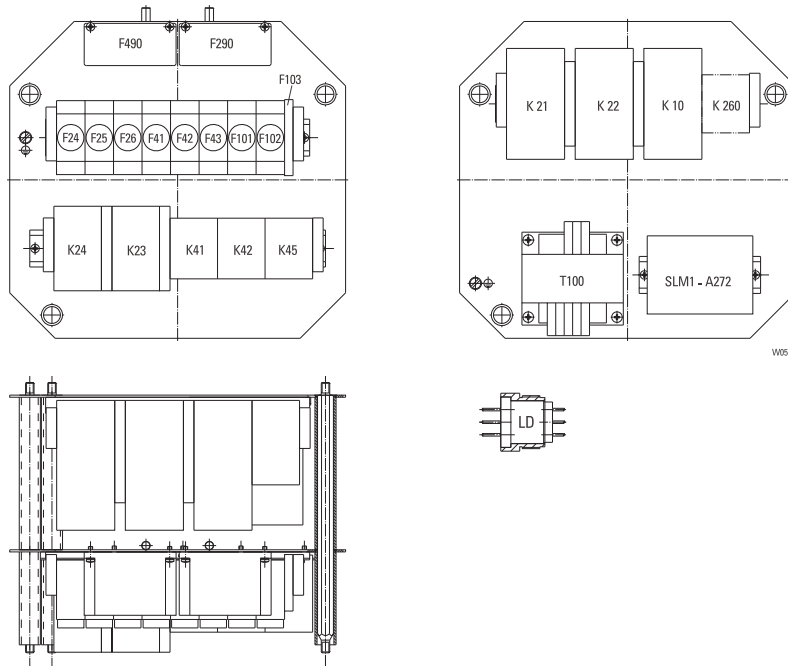

Geräteliste / parts list

Motor 12/2 A6 ex

Siehe auftragsbezogene Geräteliste in der Seilzug- Dokumentation
See parts list in individual wire rope hoist documentation.

Standardsteuergerät / Standard control switch

Typ Type	Teil-Nummer Part-Number
SWH 5102-061 ex	15 390 80 20 9
SWH 5106-061 ex	15 390 79 20 9
SWH 5202-062 ex	15 390 78 20 9
SWH 5206-062 ex	15 390 77 20 9

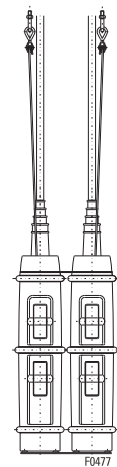

Sondersteuergeräte: Bitte Typ angeben.

Special control switches: Please state type.

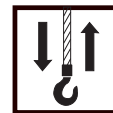

KE-S76

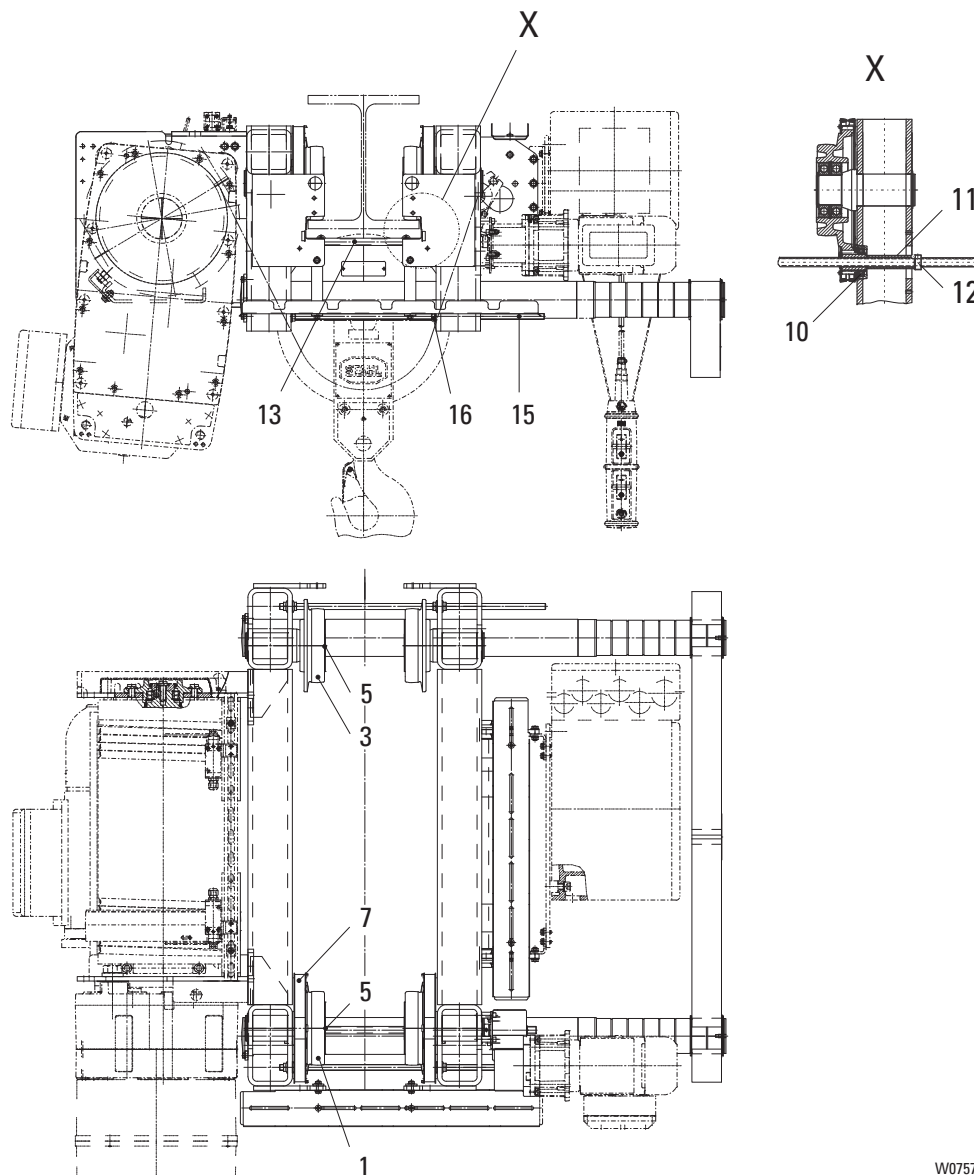

W0757

Pos	Teil-Nummer Part-Number	Stück Piece	Beschreibung Description	Benennung	Designation
1	07 250 11 40 0	2	A200	Laufrolle	Wheel
3	07 250 11 41 0	2	B200	Laufrolle	Wheel
5	506 916 0	4	65x2,5	Sicherungsring	Locking ring
7	07 250 05 42 0	2		Laufrollenabdeckung	Wheel cover
10	21 270 03 39 0	2	DIN 705	Flanschlager kompl.	Flange bearing compl.
11	21 273 00 51 0	1		Distanzrohr	Distance pipe
12	504 426 0	1		Stelling	Adjusting ring
13	21 273 15 60 0	1		Durchtriebswelle	Drive shaft
15	025 002 9	1	M16x720	Gewindebolzen	Threaded bolt
16	507 841 0	8	M16	Sicherungsmutter	Locking nut



Originalteile
Original parts
SH 6 ex

OE-S06

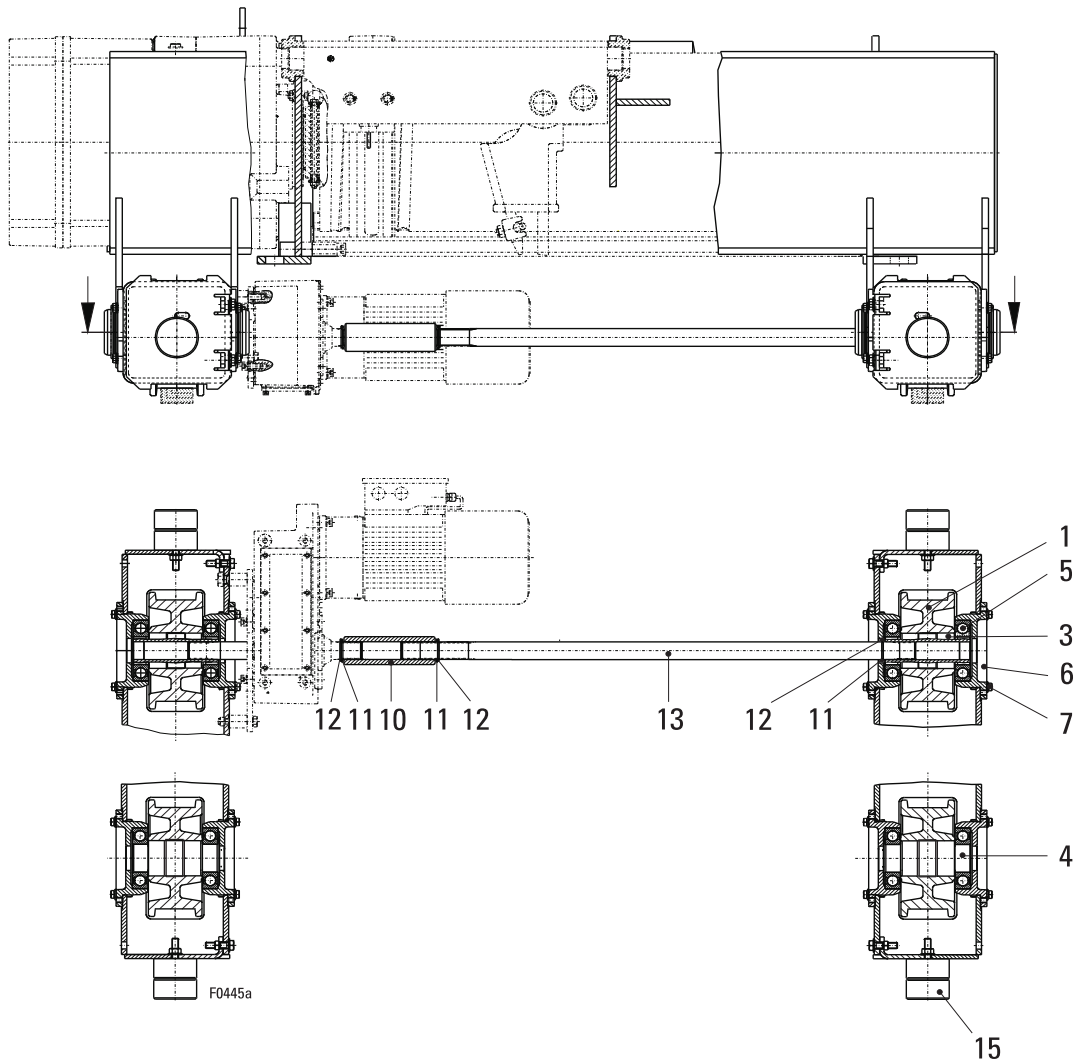

Pos	Teil-Nummer Part-Number	Stück Piece	Beschreibung Description	Benennung Designation	Designation	
1	24 254 20 01 0	4	D 160	1) 40 mm	Laufрад Wheel	
	24 254 21 01 0	4	D 160	1) 50 mm		
3	24 254 24 14 0	2		Laufradwelle	Travelling wheel shaft	
4	24 254 21 17 0	2		Laufradachse	Axle	
5	560 049 0	8	6211-2Z	DIN 625	Rillenkugellager	Grooved ball bearing
6	26 712 03 58 0	8			Lagerdeckel	Bearing cover
7	501 104 0	24	M10x20-10		Sicherungsschraube	Locking screw
10	22 275 00 35 0	1			Kupplungshülse	Coupling sleeve
11	506 815 0	3	S30x42x2,5	DIN 988	Stützscheibe	Supporting ring
12	506 121 0	3	30x2	DIN 471	Sicherungsring	Locking ring
13	22 275 04 14 0	1		2) 1250 mm	Durchtriebswelle Drive shaft	
	22 275 05 14 0	1		2) 1400 mm		
	22 275 09 14 0	1		2) 1800 mm		
	22 275 06 14 0	1		2) 2240 mm		
	22 275 07 14 0	1		2) 2800 mm		
	22 275 08 14 0	1		2) 3150 mm		
15	25 710 11 23 0	4			Puffer	Buffer

1) Schienenbreite
2) Spurweite

1) Rail width
2) Track gauge

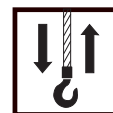

OE-S07

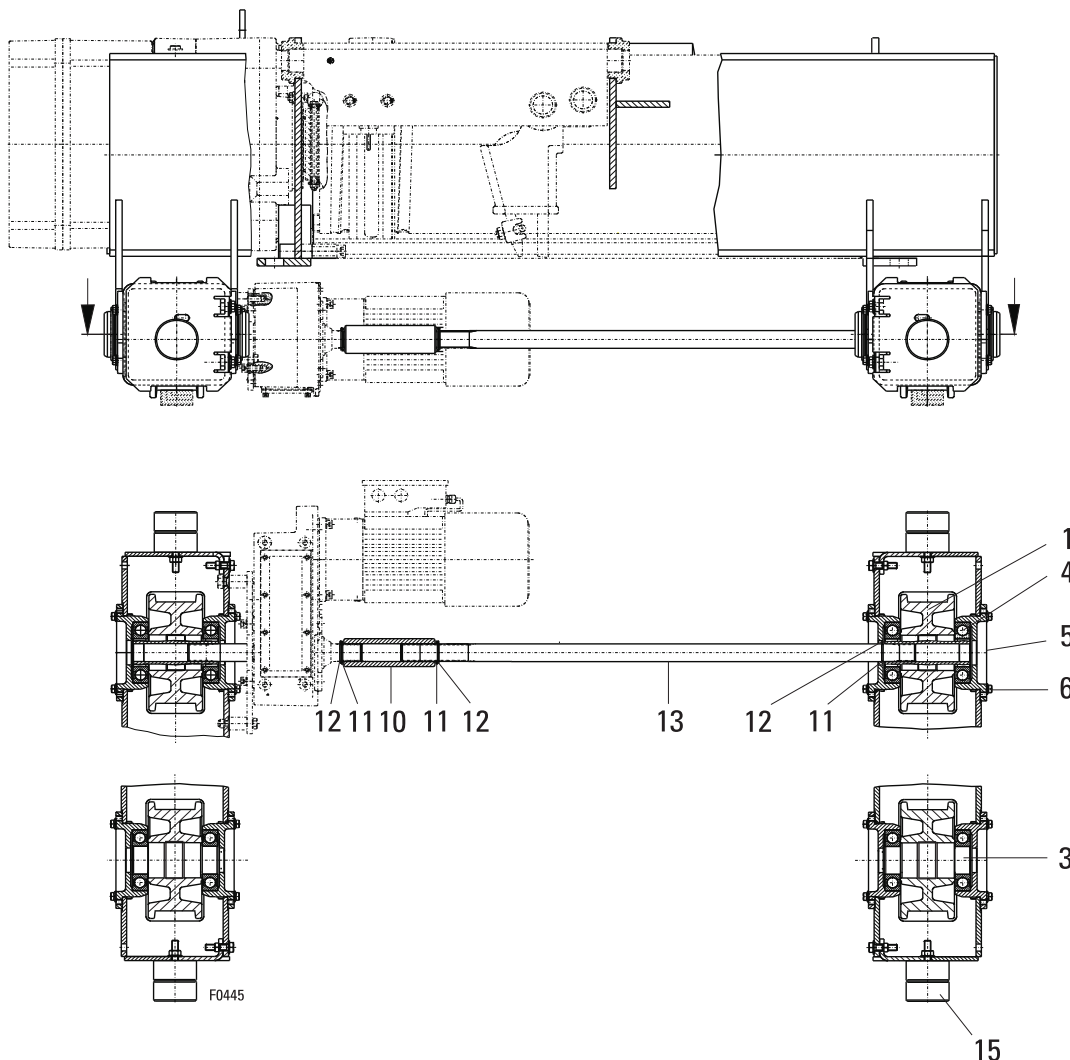

Pos	Teil-Nummer Part-Number	Stück Piece	Beschreibung Description	Benennung Designation	Designation	
1	07 257 01 01 0	2	D 200	1) k=40 mm	LaufRad	Wheel
	07 257 02 01 0	2	D 200	1) k=50 mm		
	07 257 03 01 0	2	D 200	1) k=60 mm		
3	07 257 00 05 0	2	D 200	1) k=40 mm	LaufRad	Wheel
	07 257 01 05 0	2	D 200	1) k=50 mm		
	07 257 02 05 0	2	D 200	1) k=60 mm		
4	560 040 0	8	6311-2Z	DIN 625	Rillenkugellager	Grooved ball bearing
5	27 712 03 58 0	8			Lagerflansch	Bearing flange
6	501 117 0	32	M10x30		Sicherungsschraube	Safety bolt
10	23 273 00 35 0	1			Kupplungshülse	Coupling sleeve
11	506 892 0	3	S35x45x2,5	DIN 988	Stützscheibe	Supporting ring
12	506 127 0	3	35x2,5	DIN 471	Sicherungsring	Retainer ring
13	23 273 00 14 0	1		2) 1400 mm	Durchtriebswelle	Drive shaft
	23 273 01 14 0	1		2) 1800 mm		
	23 273 02 14 0	1		2) 2240 mm		
	23 273 03 14 0	1		2) 2800 mm		
	23 273 04 14 0	1		2) 3150 mm		
15	25 710 11 23 0	4			Puffer	Buffer

1) Schienenbreite
2) Spurweite

1) Rail width
2) Track gauge

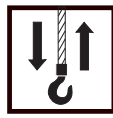

Originalteile
Original parts
SH 6 ex

A05 ex
SF 17 ... 503
SF 25 ... 503

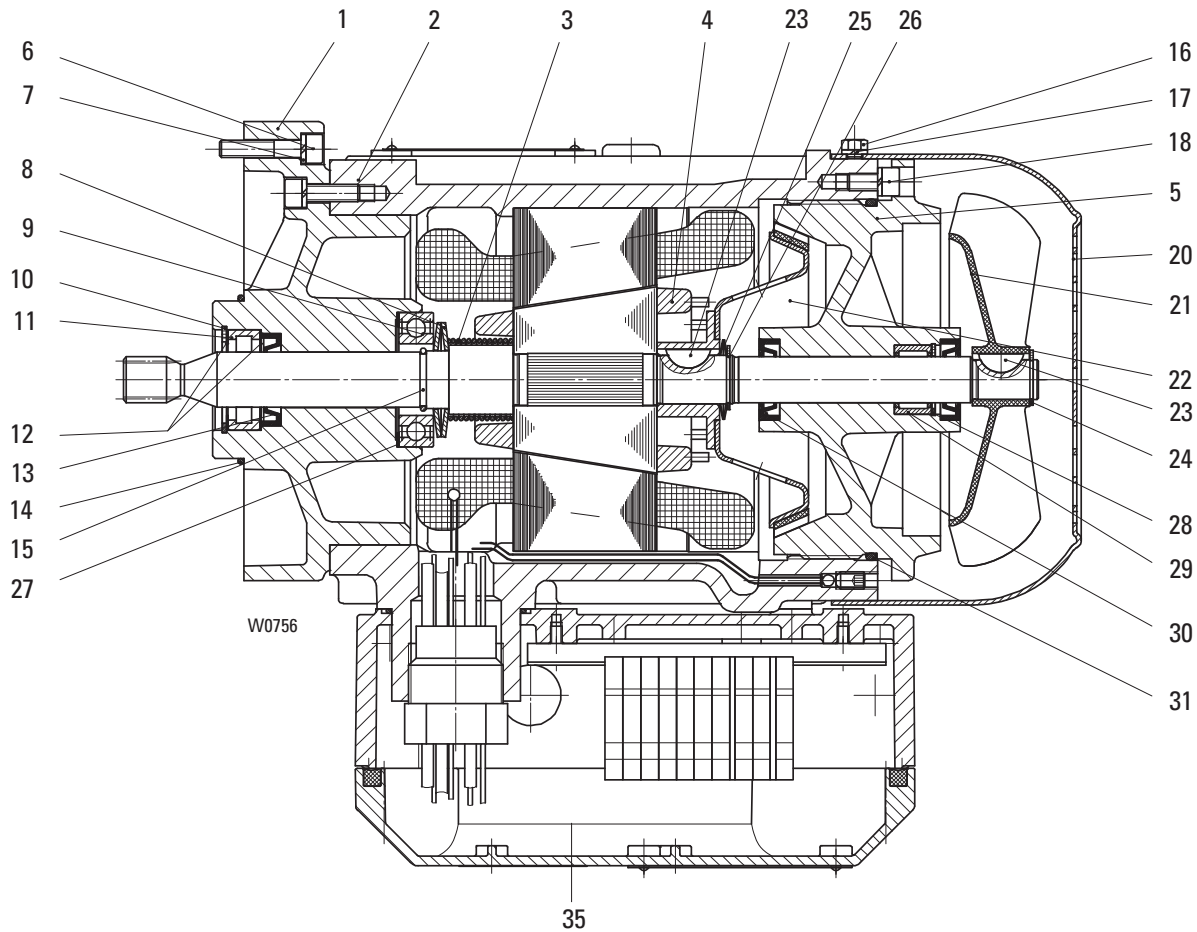

Pos	Teil-Nummer Part-Number	Stück Piece	Beschreibung Description	Benennung Designation		
	35 330 56 11 0	1	2/8A05 IIB	1) (Pos.1-31)	Motor	Motor
	35 330 57 11 0	1	2/8A05 IIC	1) (Pos.1-31))		
1	35 331 23 03 0	1	IIB		Motorflansch	Motor flange
	35 331 24 03 0	1	IIC			
2	35 330 77 14 9	1		1)	Stator	Stator
3	33 331 20 94 0	1			Druckfeder	Pressure spring
4	35 330 28 13 0	1			Rotor	Rotor
5	35 330 05 37 0	1	IIB	(Pos.28-31)	Motordeckel	Motor cover
	35 330 04 37 0	1	IIC	(Pos.28-31)		
	35 330 06 37 0	1		2) (Pos.28-31)		
6	500 976 0	8	M6X30	ISO 4762	Zyl.-Schraube	Socket head cap screw
7	506 335 0	8	6	DIN 7980	Federring	Spring washer
8	562 901 0	2	40x20,4x2,65x1,5		Tellerfeder	Cup spring
9	560 951 0	1	6005-2RS	DIN 625	Rillenkugellager	Grooved ball bearing
10	506 261 0	1	35x1,5	DIN 472	Sicherungsring	Circlip
11	506 843 0	1	RNU202E	DIN 5412	Zyl.-Rollenlager	Roller bearing
12	506 889 0	2	25x35x0,3	DIN 988	Passscheibe	Adjusting washer
13	561 893 0	1	A19x32x7	NB	Wellendichtring	Shaft seal
14	515 946 0	1	55x2	NB70	Runddichtring	Round saeling ring
15	507 836 0	1	A20	DIN 7993	Spreng ring	Sring ring
16	500 419 0	4	M5x8	ISO 4017	Skt-Schraube	Hexagon head cap screw
17	506 900 0	4	5	DIN 7980	Federring	Spring washer
18	500 230 0	4	M6x12	ISO 4762-8.8	Zyl.-Schraube	Socket head cap screw
20	35 331 22 40 0	1			Lüfterhaube	Fan cover
21	576 033 0	1	V71 R/14		Lüfterrad	Fan wheel

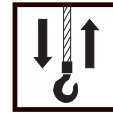

Pos	Teil-Nummer Part-Number	Stück Piece	Beschreibung Description	Benennung	Designation
22	35 330 20 18 0	1		Bremsscheibe	Brake disc
23	537 936 0	2	5x6,5 DIN 6888	Scheibefeder	Woodruf key
24	506 890 0	1	14x1 DIN 471	Sicherungsring	Circlip
25	562 949 0	2	27,7x17,3x1,45	Tellerfeder	Cup spring
26	506 386 0	1	17x1 DIN 471	Sicherungsring	Circlip
27	507 837 0	1	37x47x0,3 DIN 988	Passscheibe	Ajusting washer
28	1	M8x40 ISO 4762	Zyl-Schraube	Socket head cap screw
29	1	RNA 4901 DIN 617	Nadellager	Needle roller bearing
30	2	AS 16x28x7 NB	Wellendichtring	Shaft seal
31	1	115x3 NB 70	Runddichtring	Round sealing ring
35	02 220 20 02 0	1		Anschlusskasten	Terminal box

1) Bitte Betriebsspannung und Frequenz angeben.
2) hartverchromt

1) Please state operating voltage and frequency.
2) Hard chrome plated



Originalteile
Original parts
SH 6 ex

A1 ex
SF 17 ... 113
SF 25 ... 113

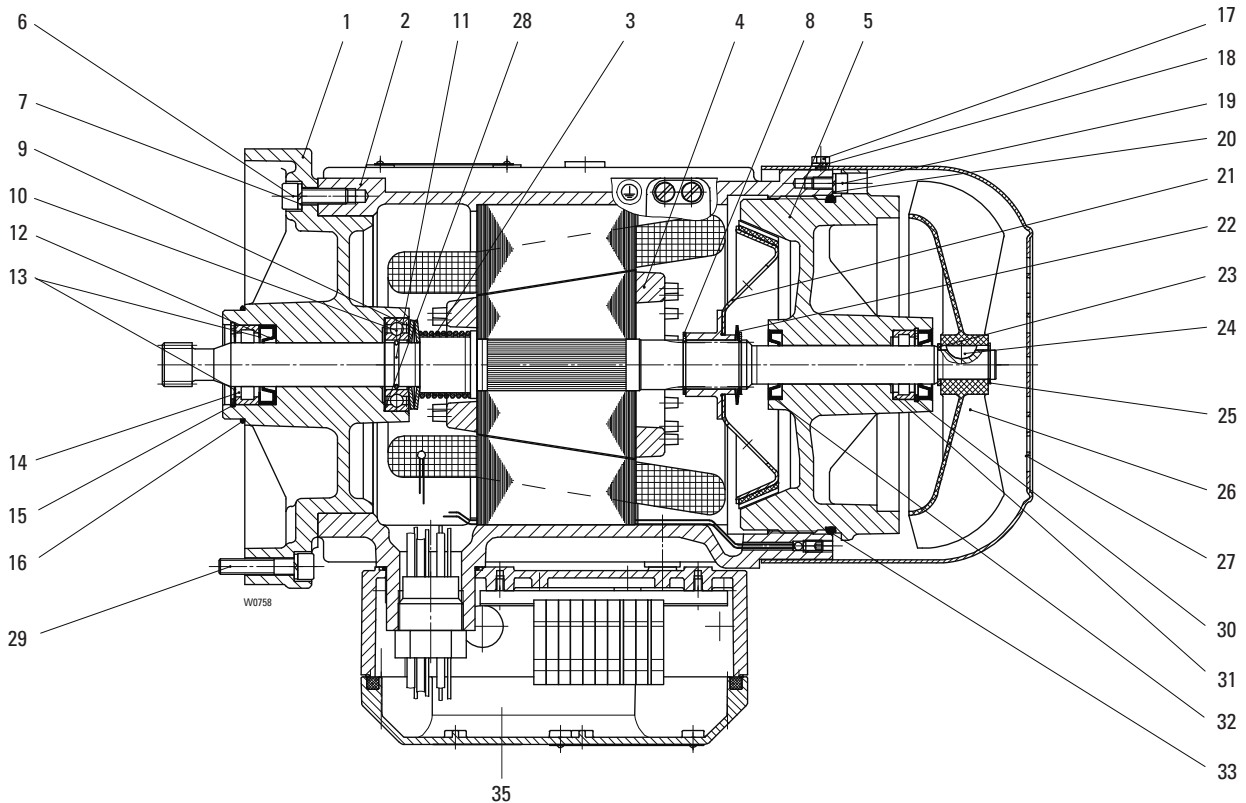

Pos	Teil-Nummer Part-Number	Stück Piece	Beschreibung Description	Benennung Designation	Designation	
1	41 330 42 11 0	1	2/8A1 IIB	1) (Pos.1-33)	Motor	Motor
	41 330 43 11 0	1	2/8A1 IIC	1) (Pos.1-33)		
2	41 331 27 03 0	1	IIB		Motorflansch	Motor flange
	41 331 28 03 0	1	IIC			
3	41 330 73 14 9	1	2/8A1	1)	Stator	Stator
4	38 331 01 94 0	1			Druckfeder	Pressure spring
5	41 330 26 13 0	1			Rotor	Rotor
6	41 330 06 37 0	1	IIB	(Pos.30-32)	Motordeckel	Motor cover
	41 330 05 37 0	1	IIC	(Pos.30-32)		
	41 330 07 37 0	1	IIC	2) (Pos.30-32)		
7	500 234 0	4	M8x25	ISO 4762	Zyl-Schraube	Socket head cap
8	506 459 0	4	8	DIN 7980	Federring	Locking ring
9	506 097 0	2	25x1,2	DIN 471	Sicherungsring	Circlip
10	41 331 00 14 0	2	45x22,4x3,05x1,75		Tellerfeder	Cup spring
11	560 951 0	1	6005-2RS	DIN 625	Rillenkugellager	Grooved ball bearing
12	561 854 0	1	A22x40x8		Wellendichtring	Shaft seal
13	506 805 0	2	28x40x0,5	DIN 988	Passscheibe	Ajusting washer
14	560 844 0	1	RNU 203 E	DIN 5412	Zyl-Rollenlager	Roller bearing
15	506 262 0	1	40x1,75	DIN 472	Sicherungsring	Circlip
16	515 946 0	1	55x2	NB70	Runddichtring	Round sealing ring
17	500 419 0	4	M5x8	ISO4017	Skt-Schraube	Hexagon head cap screw
18	506 900 0	4	5	DIN 7980	Federring	Spring washer
19	500 230 0	4	M6x12	ISO 4762	Zyl-Schraube	Socket head cap screw
20	506 335 0	4	6	DIN 7980	Federring	Spring washer
21	41 330 20 18 0	1			Bremsscheibe	brake disc
22	562 939 0	2			Tellerfeder	Cup spring

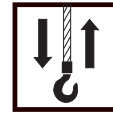

Pos	Teil-Nummer Part-Number	Stück Piece	Beschreibung Description			Benennung	Designation
23	506 844 0	1	S15x21x1,5	15x1	DIN 988	Stützscheibe	Supporting ring
24	537 936 0	1	5x6,5		DIN 6888	Scheibenfeder	Woodruff key
25	506 093 0	1			DIN 471	Sicherungsring	Circlip
26	576 030 0	1	V100 R/15			Lüfterrad	Fan wheel
27	41 331 21 40 0	1				Lüfterhaube	Fan cover
28	507 837 0	1	37x47x0,3		DIN 988	Passscheibe	Adjusting washer
29	500 146 0	4	M8x40		ISO 4762	Zyl-Schraube	Socket head cap screw
30	1	35x1,5		DIN 472	Sicherungsring	Circlip
31	1	RNU 202 E		DIN 5412	Zyl-Rollenlager	Roller bearing
32	2	A19x35x7		NB	Wellendichtring	Shaft seal
33	515 980 0	1	160x4		NB 70	Runddichtring	Round sealing ring
35	02 220 20 02 0	1				Anschlusskasten	Terminal box

1) Bitte Betriebsspannung und Frequenz angeben.
2) hartverchromt

1) Please state operating voltage and frequency.
2) Hard chrome plated



Originalteile
Original parts
SH 6 ex

A1 ex
SF 17 ... 103
SF 25 ... 103

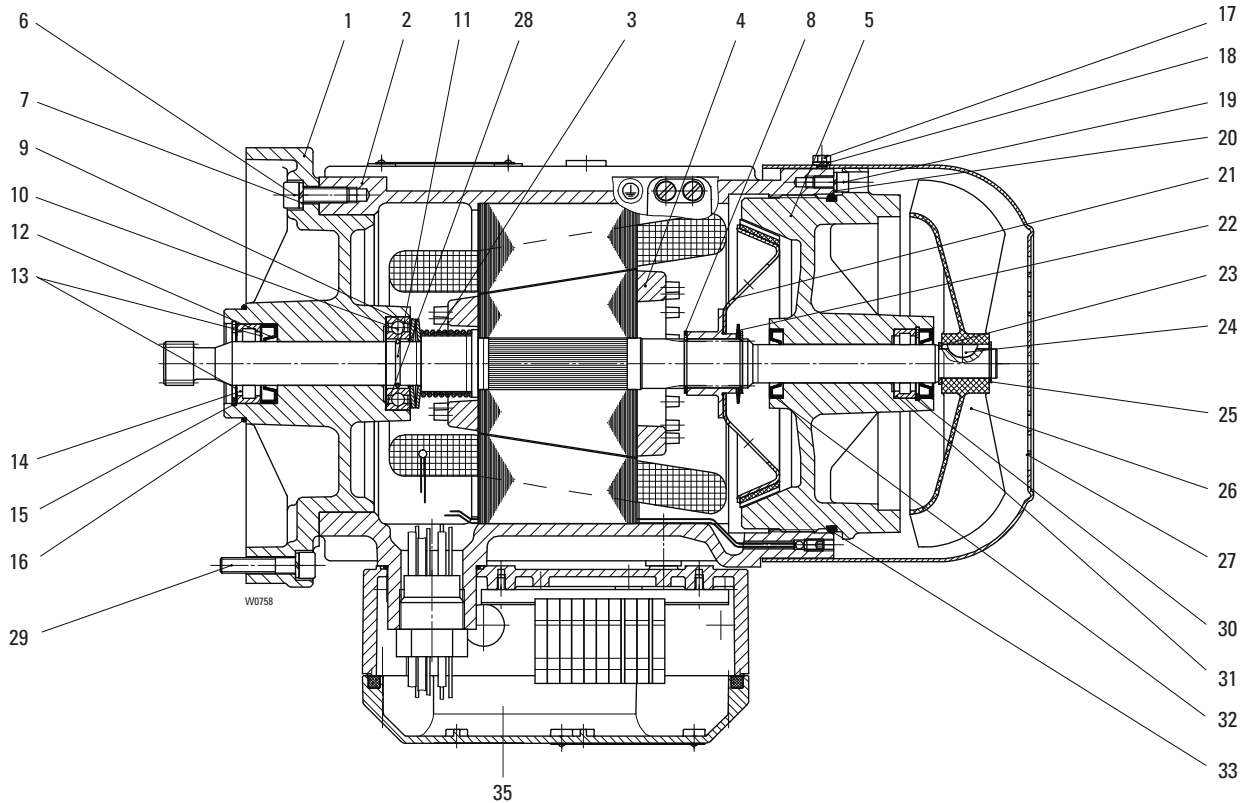

Pos	Teil-Nummer Part-Number	Stück Piece	Beschreibung Description	Benennung Designation
	41 330 40 11 0	1	2/8A1 IIB 1) (Pos.1-33)	Motor
	41 330 41 11 0	1	2/8A1 IIC 1) (Pos.1-33)	Motor
1	41 331 27 03 0	1	IIB	Motorflansch Motor flange
	41 331 28 03 0	1	IIC	
2	41 330 74 14 9	1	2/8A1 1)	Stator Stator
3	38 331 01 94 0	1		Druckfeder Pressure spring
4	41 330 26 13 0	1		Rotor Rotor
5	41 330 06 37 0	1	IIB (Pos.30-32)	Motordeckel Motor cover
	41 330 05 37 0	1	IIC (Pos.30-32)	
	41 330 07 37 0	1	IIC 2) (Pos.30-32)	
6	500 234 0	4	M8x25 ISO 4762	Zyl-Schraube Socket head cap
7	506 459 0	4	8 DIN 7980	Federring Locking ring
8	506 097 0	2	25x1,2 DIN 471	Sicherungsring Circlip
9	41 331 00 14 0	2	45x22,4x3,05x1,75	Tellerfeder Cup spring
10	560 951 0	1	6005-2RS DIN 625	Rillenkugellager Grooved ball bearing
12	561 854 0	1	A22x40x8	Wellendichtring Shaft seal
13	506 805 0	2	28x40x0,5 DIN 988	Passscheibe Adjusting washer
14	560 844 0	1	RNU 203 E DIN 5412	Zyl-Rollenlager Roller bearing
15	506 262 0	1	40x1,75 DIN 472	Sicherungsring Circlip
16	515 946 0	1	55x2 NB70	Runddichtring Round sealing ring
17	500 419 0	4	M5x8 ISO4017	Skt-Schraube Hexagon head cap screw
18	506 900 0	4	5 DIN 7980	Federring Spring washer
19	500 230 0	4	M6x12 ISO 4762	Zyl-Schraube Socket head cap screw
20	506 335 0	4	6 DIN 7980	Federring Spring washer
21	41 330 20 18 0	1		Bremsscheibe brake disc
22	562 939 0	2		Tellerfeder Cup spring

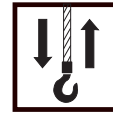

Pos	Teil-Nummer Part-Number	Stück Piece	Beschreibung Description			Benennung	Designation
23	506 844 0	1	S15x21x1,5	15x1	DIN 988	Stützscheibe	Supporting ring
24	537 936 0	1	5x6,5		DIN 6888	Scheibefeder	Woodruf key
25	506 093 0	1			DIN 471	Sicherungsring	Circlip
26	576 030 0	1	V100 R/15			Lüfterrad	Fan wheel
27	41 331 21 40 0	1				Lüfterhaube	Fan cover
28	507 837 0	1	37x47x0,3		DIN 988	Passscheibe	Ajusting washer
29	500 146 0	4	M8x40		ISO 4762	Zyl-Schraube	Socket head cap screw
30	1	35x1,5		DIN 472	Sicherungsring	Circlip
31	1	RNU 202 E		DIN 5412	Zyl-Rollenlager	Roller bearing
32	2	A19x35x7		NB	Wellendichtring	Shaft seal
33	515 980 0	1	160x4		NB 70	Runddichtring	Round sealing ring
35	02 220 20 02 0	1				Anschlusskasten	Terminal box

1) Bitte Betriebsspannung und Frequenz angeben.
2) hartverchromt

1) Please state operating voltage and frequency.
2) Hard chrome plated



Originalteile
Original parts
SH 6 ex

A2 ex
SF 25 ... 203
SF 35 ... 203

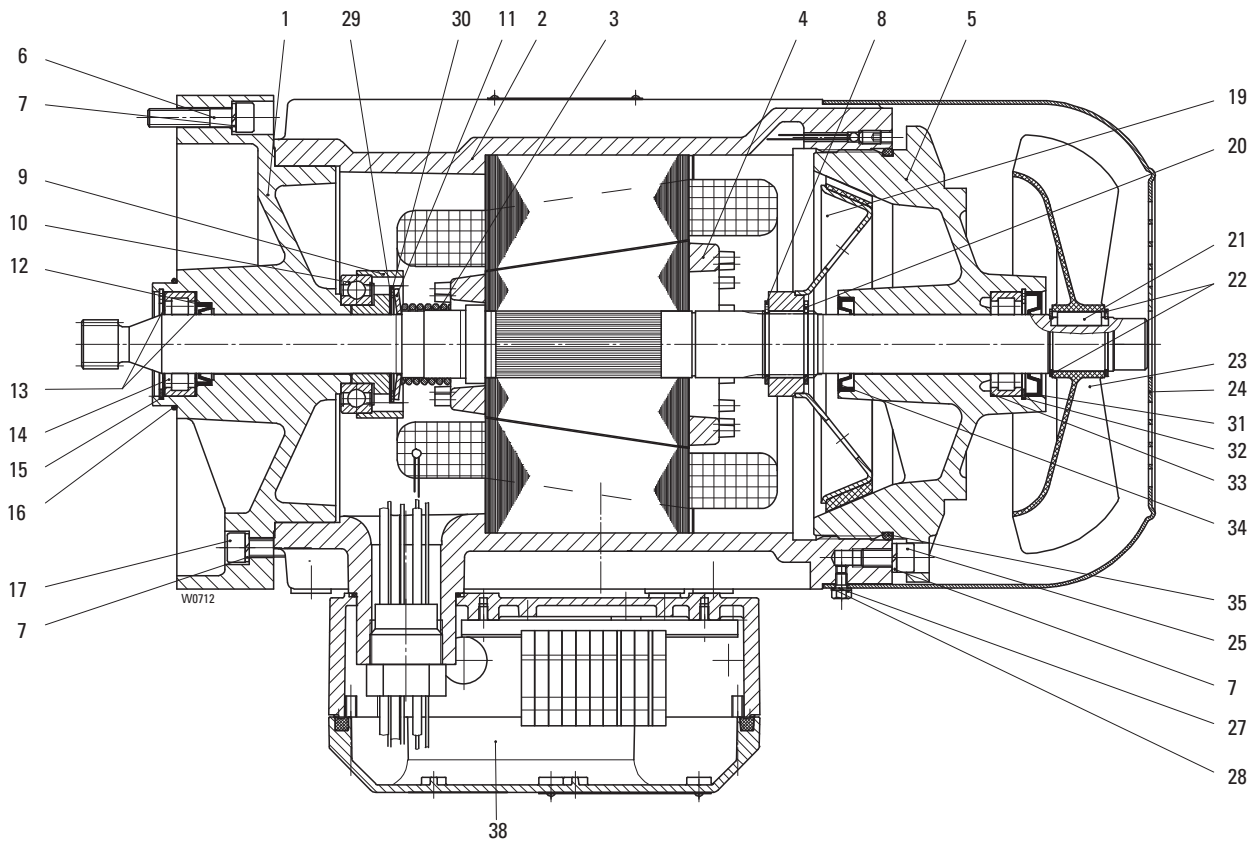

Pos	Teil-Nummer Part-Number	Stück Piece	Beschreibung Description	Benennung Designation	Designation
1	42 330 52 10 0	1	2/08A2 IIB 1) (Pos.1-35)	Motor	Motor
	42 330 53 10 0	1	2/08A2 IIC 1) (Pos.1-35)	Motor	Motor
2	42 331 22 03 0	1	IIB	Motorflansch	Motor flange
	42 331 23 03 0	1	IIC	Motorflansch	Motor flange
3	42 330 74 14 9	1	2/08A2 1)	Stator	Stator
4	42 331 00 94 0	1		Druckfeder	Pressure spring
5	42 330 21 13 0	1		Rotor	Rotor
6	42 330 06 37 0	1	IIB (Pos.31-35)	Motordeckel	Motor cover
	42 330 04 37 0	1	IIC (Pos.31-35)	Motordeckel	Motor cover
	42 330 03 37 0	1	IIC 2) (Pos.31-35)	Motordeckel	Motor cover
7	500 146 0	4	M8x40 ISO 4762-8.8	Zyl-Schraube	Socket head cap screw
8	506 459 0	12	8 DIN 7980	Federring	Spring washer
9	506 098 0	1	30x1,5 DIN 471	Sicherungsring	Circlip
10	42 331 20 51 0	1		Abstandsring	Spacer ring
11	560 067 0	1	6007-2RS-C3 DIN 625	Rillenkugellager	Roller bearing
12	42 331 00 14 0	1	500x27,3x3,4x2	Tellerfeder	Cup spring
13	561 822 0	1	A27x37x7	Wellendichtring	Shaft seal
14	42 331 00 52 0	2		Scheibe	Disc
15	560 845 0	1	RNU 204 E DIN 5412	Zyl-Rollenlager	Roller bearing
16	506 106 0	1	47x1,75 DIN 472	Sicherungsring	Circlip
17	515 946 0	1	55x2 NB70	Runddichtring	Round sealing ring
18	500 234 0	4	M8x25 ISO 4762	Zyl-Schraube	Socket head cap screw
19	42 330 20 18 0	1		Bremsscheibe	Brake disc
20	506 569 0	1	A30x1,5L	Sicherungsring	Circlip
21	537 958 0	1	B6x6x20 DIN 6885	Passfeder	Key



Pos	Teil-Nummer Part-Number	Stück Piece	Beschreibung Description	Benennung	Designation
22	506 428 0	2	24x1,2 DIN 471	Sicherungsring	Circlip
23	576 019 0	1	V100 R/24	Lüfterrad	Fan wheel
24	42 331 20 40 0	1		Lüfterhaube	Fan cover
25	500 144 0	4	M8x16 ISO 4762-8.8	Zyl-Schraube	Socket head cap screw
27	500 419 0	4	M5x8 ISO 4017	Skt-Schraube	Hexagon head cap screw
28	506 042 0	4	A5 DIN 127	Sicherungsring	Circlip
29	507 817 0	3	42x52x0,3 DIN 988	Passscheibe	Ajusting washer
30	507 816 0	1	42x52x1 DIN 988	Passscheibe	Ajusting washer
31	1		Wellendichtring	Shaft seal
32	1	47x1,75 DIN 472	Sicherungsring	Circlip
33	1	RNU 204 E DIN 5412	Zyl-Rollenlager	Roller bearing
34	1	A27x42x7	Wellendichtring	Shaft seal
35	515 980 0	1	160x4 NB 70	Runddichtring	Round sealing ring
38	02 220 20 02 0	1		Anschlusskasten	Terminal box

1) Bitte Betriebsspannung und Frequenz angeben.
2) hartverchromt

1) Please state operating voltage and frequency.
2) Hard chrome plated



Originalteile
Original parts
SH 6 ex

SF 17 2..

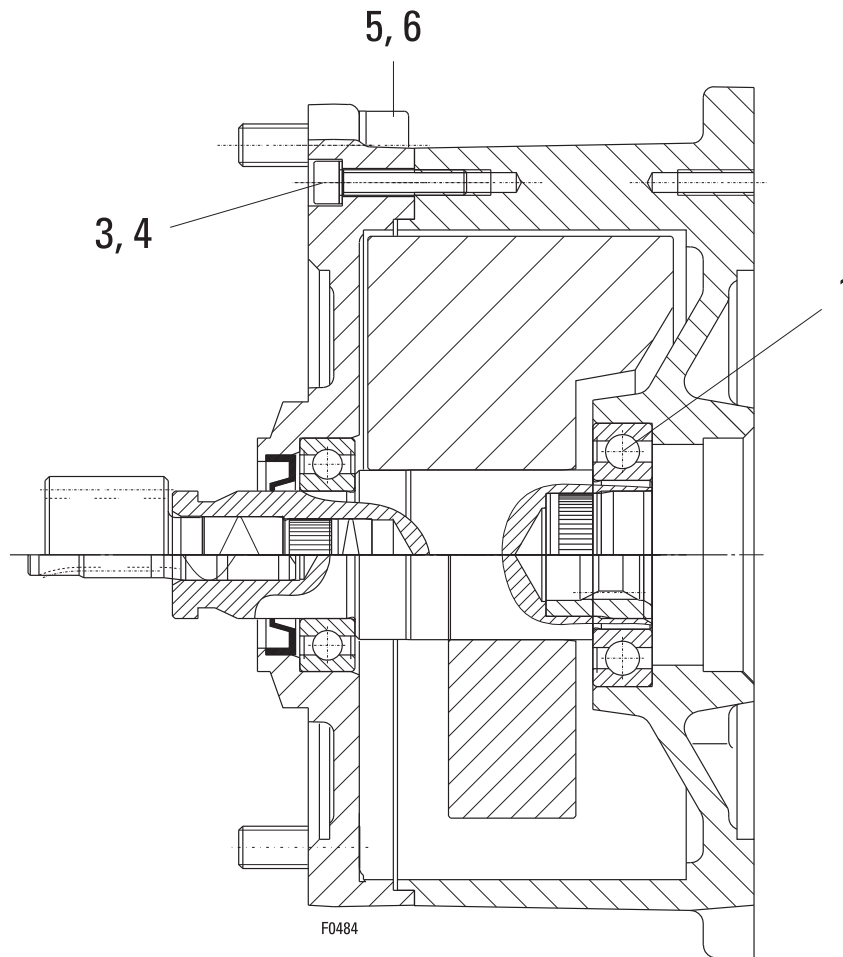

Pos	Teil-Nummer Part-Number	Stück Piece	Beschreibung Description	Benennung	Designation		
	21 270 10 32 0	1	SF 17 219 503	Schwungradkupplung	Flywheel coupling		
	21 270 11 32 0	1	SF 17 217 503				
	21 270 12 32 0	1	SF 17 215 503				
	21 270 13 32 0	1	SF 17 213 503				
	21 270 14 32 0	1	SF 17 211 503				
	21 270 15 32 0	1	SF 17 209 503				
	21 270 16 32 0	1	SF 17 207 503				
	21 270 18 32 0	1	SF 17 217 113				
	21 270 19 32 0	1	SF 17 215 113				
	21 270 20 32 0	1	SF 17 213 113				
	21 270 21 32 0	1	SF 17 211 113				
	21 270 22 32 0	1	SF 17 209 113				
	21 270 23 32 0	1	SF 17 207 113				
	21 270 28 32 0	1	SF 17 211 103				
	21 270 29 32 0	1	SF 17 209 103				
	21 270 30 32 0	1	SF 17 207 103				
1	560 989 0	1	6007-2Z DIN 625			Rillenkugellager	Grooved ball bearing
3	500 976 0	8	M6x30 ISO 4762-8.8			Zyl-Schraube	Socket head cap screw
4	506 838 0	8	S6			Sicherungsscheibe	Lock washer
5	500 236 0	4	M10x30 DIN 912-8.8			Zyl-Schraube	Socket head cap screw
6	506 128 0	4	VS10	Sicherungsscheibe	Lock washer		

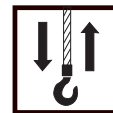

SF 25 ...

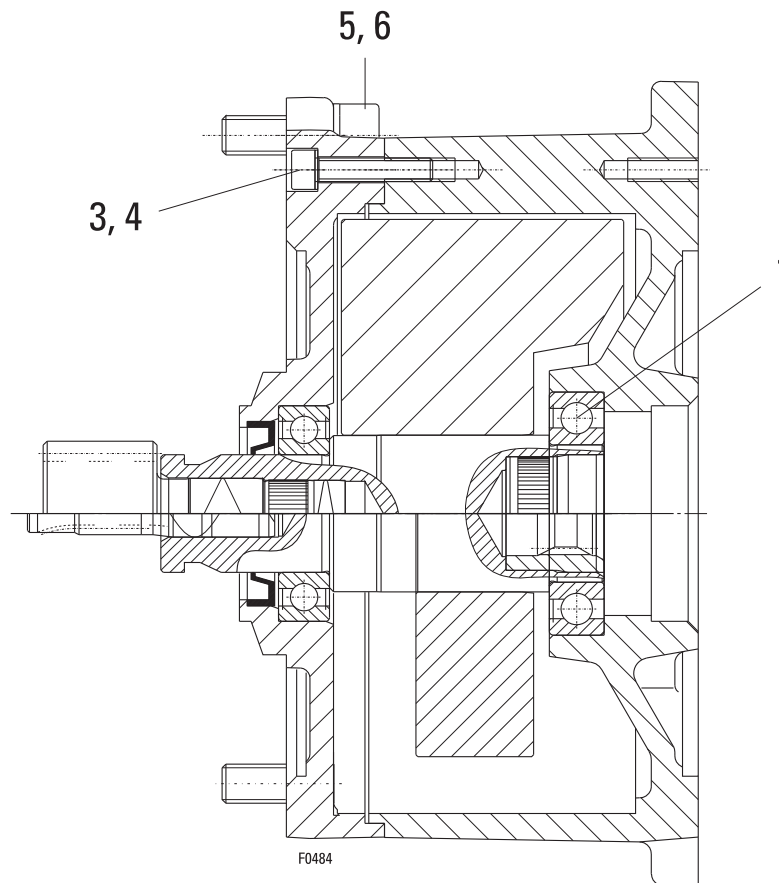

Pos	Teil-Nummer Part-Number	Stück Piece	Beschreibung Description	Benennung	Designation
	21 270 10 32 0	1	SF 25 230 503	Schwungradkupplung	Flywheel coupling
	21 270 11 32 0	1	SF 25 228 503		
		1	SF 25 226 503		
	21 270 13 32 0	1	SF 25 224 503		
		1	SF 25 222 503		
	21 270 15 32 0	1	SF 25 220 503		
	21 270 32 32 0	1	SF 25 228 113		
		1	SF 25 226 113		
	21 270 34 32 0	1	SF 25 224 113		
		1	SF 25 222 113		
	21 270 36 32 0	1	SF 25 220 113		
		1	SF 25 218 113		
	21 270 38 32 0	1	SF 25 216 113		
	21 270 27 32 0	1	SF 25 224 103		
		1	SF 25 222 103		
	21 270 29 32 0	1	SF 25 220 103		
		1	SF 25 218 103		
	21 270 31 32 0	1	SF 25 216 103		
	22 270 11 32 0	1	SF 25 220 203		
			SF 25 218 203		
	22 270 13 32 0	1	SF 25 216 203		
	21 270 38 32 0	1	SF 25 83. 113		
1	560 989 0	1	6007-2Z	Rillenkugellager	Grooved ball bearing
3	500 976 0	8	M6x30	Zyl-Schraube Sicherungsscheibe	Socket head cap screw Lock washer
4	506 838 0	8	S6		
5	500 236 0	4	M10x30	Zyl-Schraube Sicherungsscheibe	Socket head cap screw Lock washer
6	506 128 0	4	VS10		

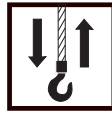

Originalteile
Original parts
SH 6 ex

SF 35 ...

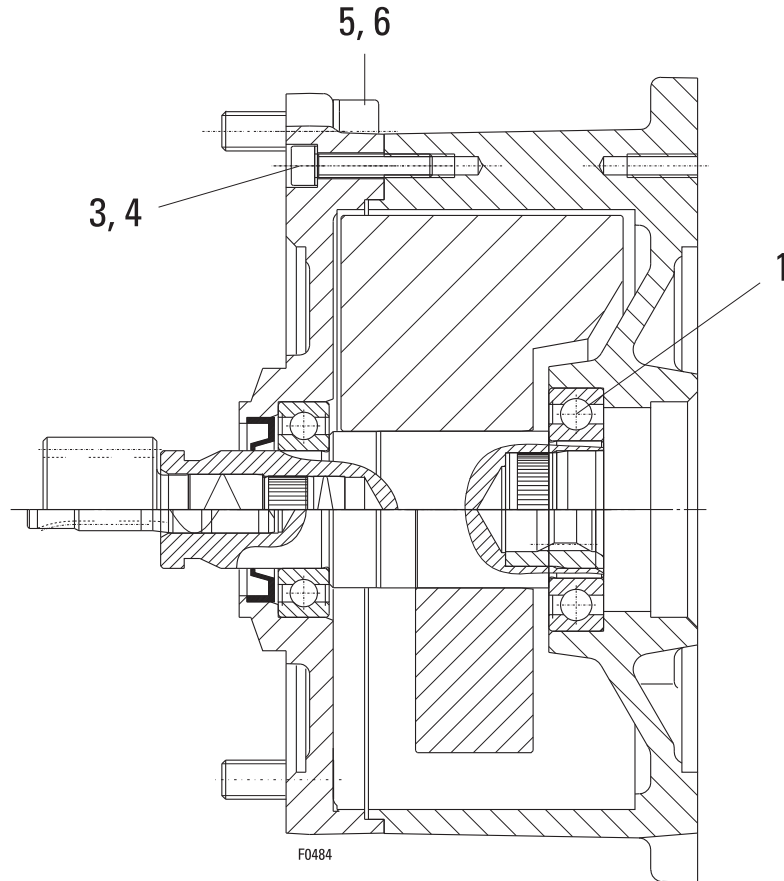

Pos	Teil-Nummer Part-Number	Stück Piece	Beschreibung Description	Benennung Designation	Designation	
	21 270 33 32 0	1	SF 35 230 113	Schwungradkupplung	Flywheel coupling	
	21 270 34 32 0	1	SF 35 228 113			
		1	SF 35 226 113			
	21 270 26 32 0	1	SF 35 230 103			
	21 270 27 32 0	1	SF 35 228 103			
		1	SF 35 226 103			
	21 270 29 32 0	1	SF 35 224 103			
		1	SF 35 222 103			
	22 270 10 32 0	1	SF 35 228 203			
		1	SF 35 226 203			
	22 270 11 32 0	1	SF 35 216 203			
		1	SF 35 224 203			
		1	SF 35 222 203			
	22 270 13 32 0	1	SF 35 220 203			
	21 270 38 32 0	1	SF 35 83. 113			
1	560 989 0	1	6007-2Z	DIN 625	Rillenkugellager	Grooved ball bearing
3	500 976 0	8	M6x30	ISO 4762-8.8	Zyl-Schraube	Socket head cap screw
4	506 838 0	8	S6			
5	500 236 0	4	M10x30	DIN 912-8.8	Zyl-Schraube	Socket head cap screw
6	506 128 0	4	VS10			

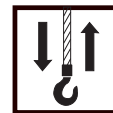

SF 17 2..

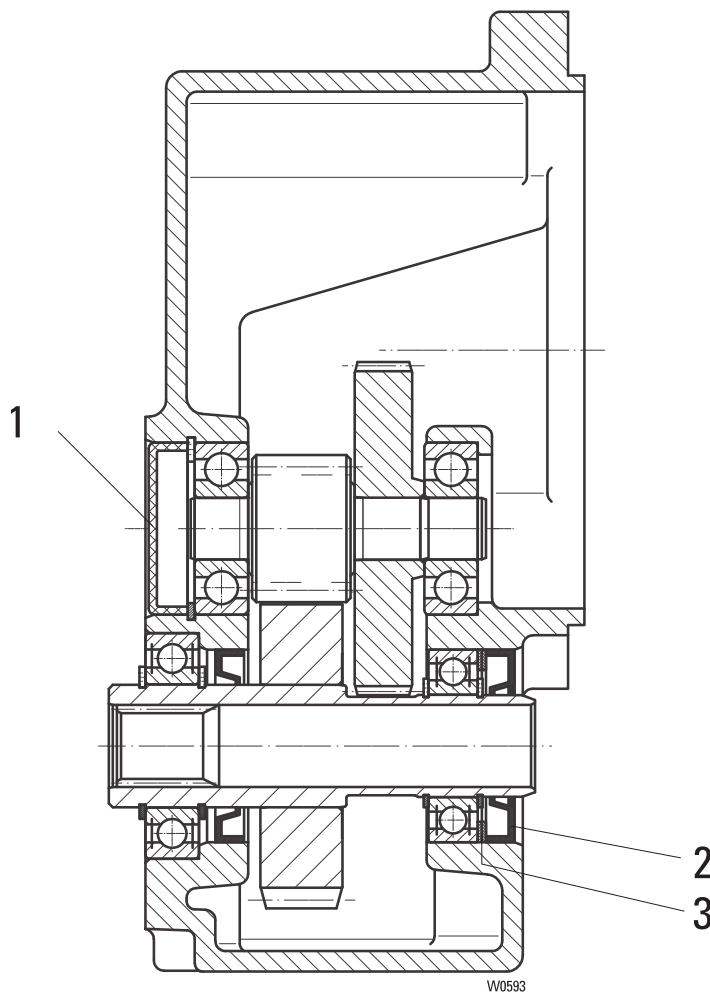

Pos	Teil-Nummer Part-Number	Stück Piece	Beschreibung Description	Benennung	Designation
	21 270 04 30 0	1	SF17 219	Getriebe	Gear
	21 270 05 30 0	1	SF17 217		
	21 270 06 30 0	1	SF17 215		
	21 270 07 30 0	1	SF17 213		
	21 270 08 30 0	1	SF17 211		
	21 270 09 30 0	1	SF17 209		
	21 270 10 30 0	1	SF17 207		
1	518 036 0	1	42x9,5		
2	561 120 0	1	25x47x7	Wellendichtring	Shaft seal
3	507 876 0	2	37x47x1	Passscheibe	Adjusting washer

1) Getriebe bis auf gekennzeichnete Teile nur komplett lieferbar.
Ohne Getriebeöl: Erforderliche Menge siehe Betriebsanleitung

1) Gear only available as complete unit except the signed parts
Without gear oil: amount required see operating instruction.



Originalteile
Original parts
SH 6 ex

SF 25 83.

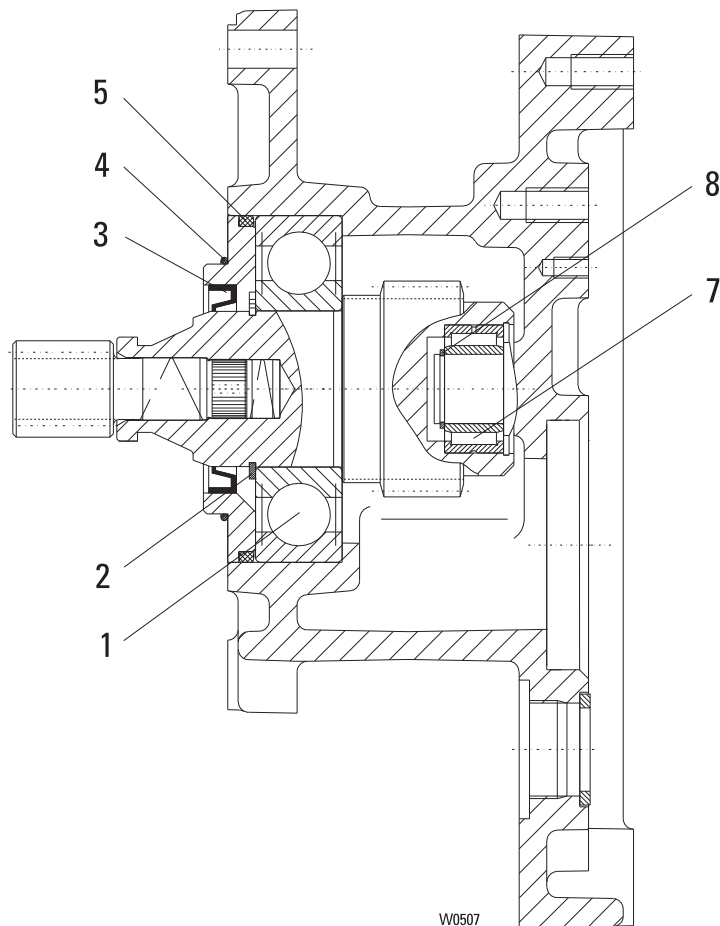

Pos	Teil-Nummer Part-Number	Stück Piece	Beschreibung Description	Benennung	Designation
	24 270 39 30 0	1	SF 25 832	Zwischengetriebe	Intermediate gear
		1	SF 25 834		
	24 270 37 30 0	1	SF 25 830		
1	560 829 0	1	6309-27 DIN 625	Rillenkugellager	Grooved ball bearing
2	506 101 0	1	45x1,75 DIN 471	Sicherungsring	Locking ring
3	561 026 0	1	45x60x8 NB DIN 3760	Wellendichtring	Shaft seal
4	515 953 0	1	70x2 NB 70	Runddichtring	Round sealing ring
5	515 970 0	1	90x4 NB 70	Runddichtring	Round sealing ring
7	560 995 0	1	NA 4904 DIN 5617	Nadellager	needle roller bearing
8	507 122 0	1	SW 20	Sprengring	Circlip

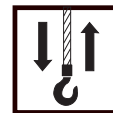

SF 25 ...

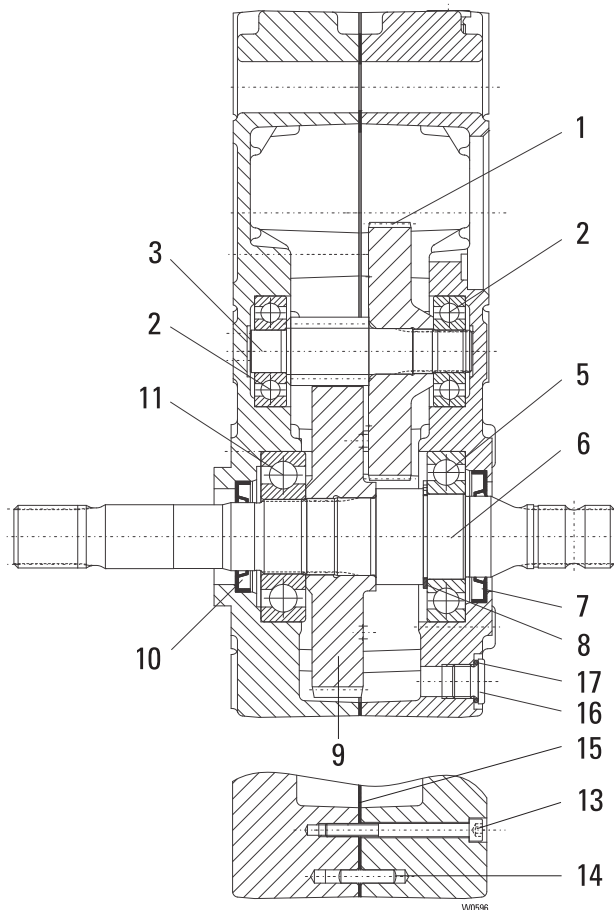

Pos	Teil-Nummer Part-Number	Stück Piece	Beschreibung Description	Benennung	Designation
	22 270 00 30 0	1	SF 25 228, SF 25 834 1)	Getriebe	Gear
	22 270 01 30 0	1	SF 25 226, SF 25 832 1)		
	22 270 02 30 0	1	SF 25 224, SF 25 830 1)		
	22 270 03 30 0	1	SF 25 222 1)		
	22 270 04 30 0	1	SF 25 220 1)		
	22 270 05 30 0	1	SF 25 218 1)		
	22 270 06 30 0	1	SF 25 216 1)		
	22 270 16 30 0	1	SF 25 230 1)		
1	22 273 05 11 0	1	SF 25 228, SF 25 226 SF 25 834, SF 25 832	Zahnrad	Toothed wheel
	22 273 04 11 0	1	SF 25 224, SF 25 222 SF 25 830		
	22 273 03 11 0	1	SF 25 220, SF 25 218		
	22 273 02 11 0	1	SF 25 216		
	22 273 08 11 0	1	SF 25 230		
2	560 053 0	2	6304 DIN 625	Rillenkugellager	Grooved ball bearing
3	23 273 00 19 0	1	SF 25 228, SF 25 224 SF 25 220, SF 25 216, SF 25 230	Ritzelwelle	Pinion shaft
		1	SF 25 834, SF 25 830		
5	23 273 01 19 0	1	SF 25 226, SF 25 222 SF 25 218 SF 25 832		
	560 986 0	1	6208-C3 DIN 625	Rillenkugellager	Grooved ball bearing
6	22 273 02 23 0	1		Abtriebswelle	Drive shaft
7	561 125 0	1	38x62x7 DIN 3760	Wellendichtring	Shaft seal
8	506 247 0	1	40x1,75 DIN 471	Sicherungsring	Locking ring
9	22 273 07 11 0	1	SF 25 228, SF 25 224 SF 25 220, SF 25 216, SF 25 230	Zahnrad	Toothed wheel
		1	SF 25 832, SF 25 830		
	22 273 06 11 0	1	SF 25 226, SF 25 222 SF 25 218 SF 25 832		
10	561 992 0	1	32x52x7 DIN 3760	Wellendichtring	Shaft seal
11	560 061 0	1	6307 DIN 625	Rillenkugellager	Grooved ball bearing
13	500 804 0	8	M6x65 ISO 4762	Zyl.-Schraube	Socketed head cap screw
14	504 029 0	4	6m6x24 ISO 2338	Zyl.-Stift	Pin
15	22 273 00 95 0	1		Dichtung	Seal
16	503 954 0	2		Verschlusssschraube	Locking bolt
17	515 004 0	2	C16X20 DIN 7603	Dichtring	Washer

1) Ohne Getriebeöl: Erforderliche Menge siehe Betriebsanleitung

1) Without gear oil: amount required see operating instruction



Originalteile
Original parts
SH 6 ex

SF 35 83.

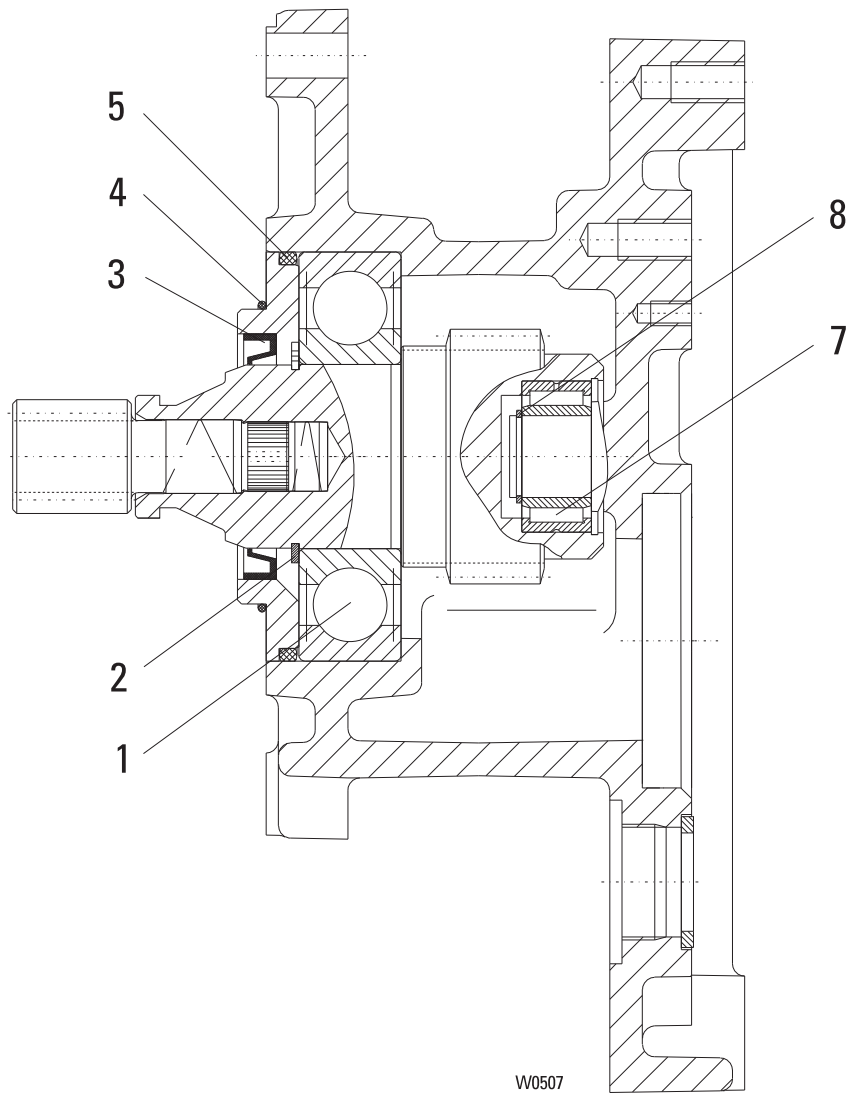

W0507

Pos	Teil-Nummer Part-Number	Stück Piece	Beschreibung Description	Benennung	Designation
	24 270 40 30 0	1	SF 35 836	Zwischengetriebe	Intermediate gear
	24 270 37 30 0	1	SF 35 834		
		1	SF 35 832		
1	560 829 0	1	6309-27	Rillenkugellager	Grooved ball bearing
2	506 101 0	1	45x1,75	Sicherungsring	Locking ring
3	561 026 0	1	45x60x8 NB	Wellendichtring	Shaft seal
4	515 953 0	1	70x2	Runddichtring	Round sealing ring
5	515 970 0	1	90x4	Runddichtring	Round sealing ring
7	560 995 0	1	NA 4904	Nadellager	needle roller bearing
8	507 122 0	1	SW 20	Sprengtring	Circlip

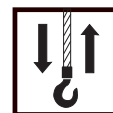

SF 35 ...

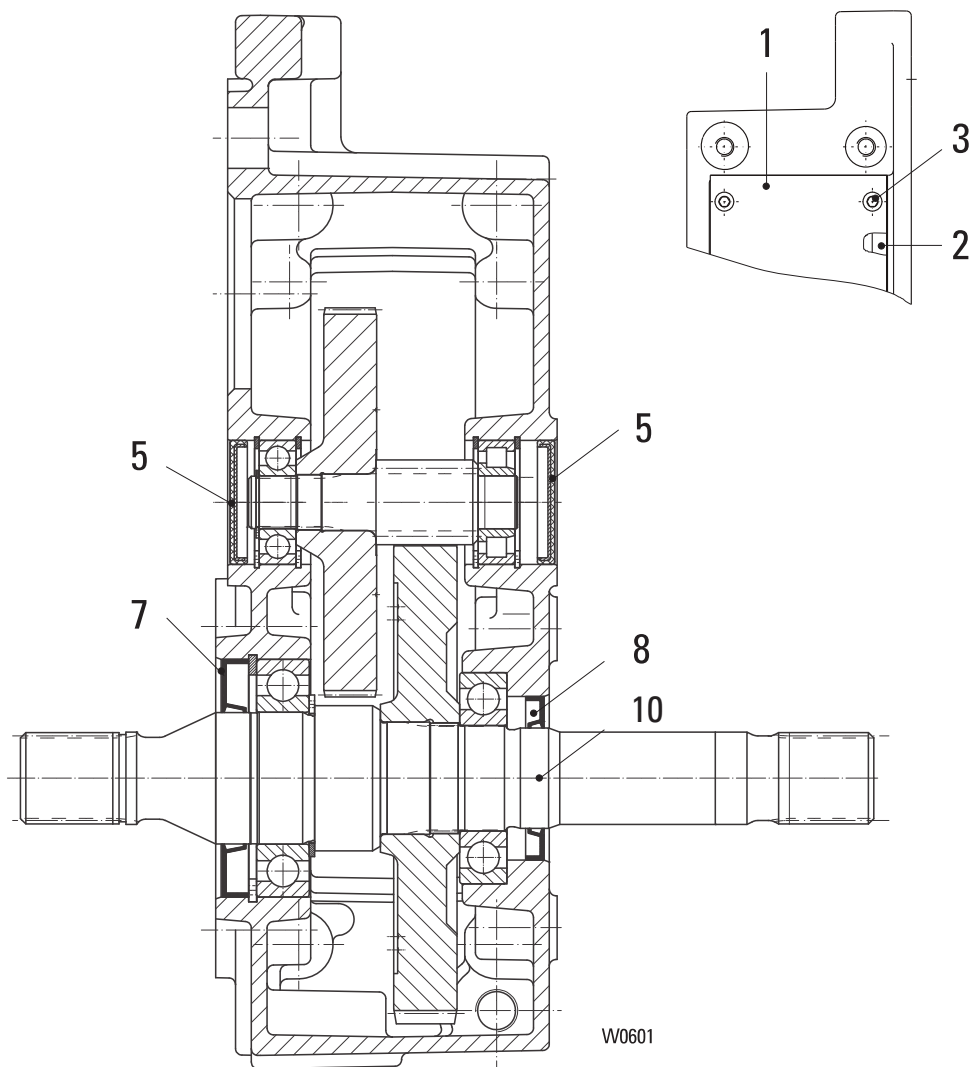

Pos	Teil-Nummer Part-Number	Stück Piece	Beschreibung Description	Benennung	Designation
	23 270 10 30 0	1	SF 35 230	Getriebe	Gear
		1	SF 35 836		
	23 270 11 30 0	1	SF 35 228		
		1	SF 35 834		
	23 270 12 30 0	1	SF 35 226		
		1	SF 35 832		
	23 270 13 30 0	1	SF 35 224		
	23 270 14 30 0	1	SF 35 222		
	23 270 15 30 0	1	SF 35 220		
1	23 273 00 96 0	1			
2	23 273 00 95 0	1		Dichtung	Seal
3	500 810 0	8	M6x16 DIN 6912-8.8	Zyl-Schraube	Socket head cap screw
5	518 041 0	1	47x6,5	Verschlusskappe	End cap
7	561 126 0	1	AS50x90x10	Wellendichtring	Shaft seal
8	561 125 0	1	AS38x72x7	Wellendichtring	Shaft seal
10	23 273 03 23 0	1		Abtriebswelle	Drive shaft

1) Getriebe bis auf gekennzeichnete Teile nur komplett lieferbar.
Ohne Getriebeöl: Erforderliche Menge siehe Betriebsanleitung

1) Gear only available as complete unit except the signed parts
Without gear oil: amount required see operating instruction.



Originalteile
Original parts
SH 6 ex

SF 17

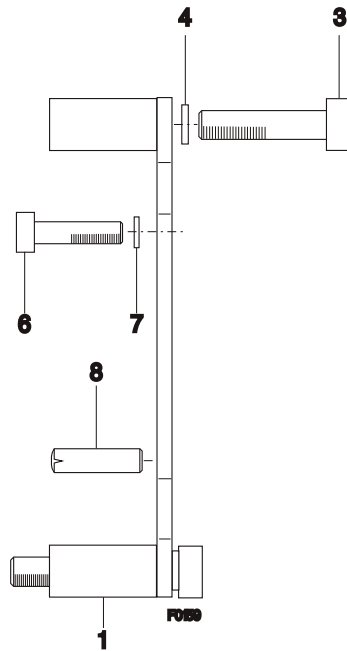

Pos	Teil-Nummer Part-Number	Stück Piece	Beschreibung Description	Benennung	Designation
1	21 270 01 22 0	1	SF1 (Pos.3-8)	Drehmomentstütze	Torque support
3	500 980 0	4	M8x45 DIN 912-8.8	Zyl-Schraube	Socket head cap screw
4	506 839 0	4	S8	Sicherungsscheibe	Locking disc
6	500 144 0	4	M8x16 DIN 912-8.8	Zyl-Schraube	Socket head screw
7	506 839 0	4	S8	Sicherungsscheibe	Locking disc
8	504 960 0	2	8m6x24 DIN 7	Zyl-Stift	Pin

SF 25

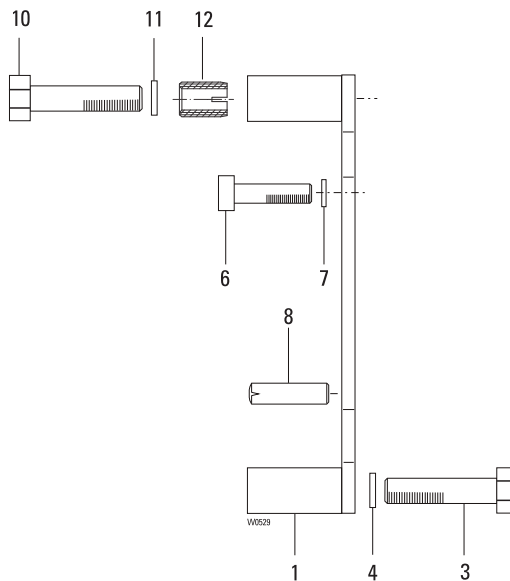

Pos	Teil-Nummer Part-Number	Stück Piece	Beschreibung Description	Benennung	Designation
1	22 270 03 22 0	1	SF 25 (Pos.3-11)	Drehmomentstütze	Torque support
3	500 205 0	2	M12x50 8.8 ISO 4014	Skt-Schraube	Hexagon head cap screw
4	507 104 0	2	SKM12	Sperrkantscheibe	Locking disc
6	500 234 0	4	M8x25 8.8 ISO 4762	Zyl-Schraube	Socket head screw
7	506 839 0	4	S8	Sicherungsscheibe	Locking disc
8	504 960 0	2	8m6x24 DIN 7	Zyl-Stift	Pin
10	500 303 0	2	M12x40 8.8 ISO 4017	Skt-Schraube	Hexagon head cap screw
11	507 104 0	2	SKM12	Sperrkantscheibe	Locking disc
12	5216 000 0	2	M12x22 IN 22b	Ensat	Ensat

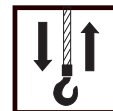

SF 35

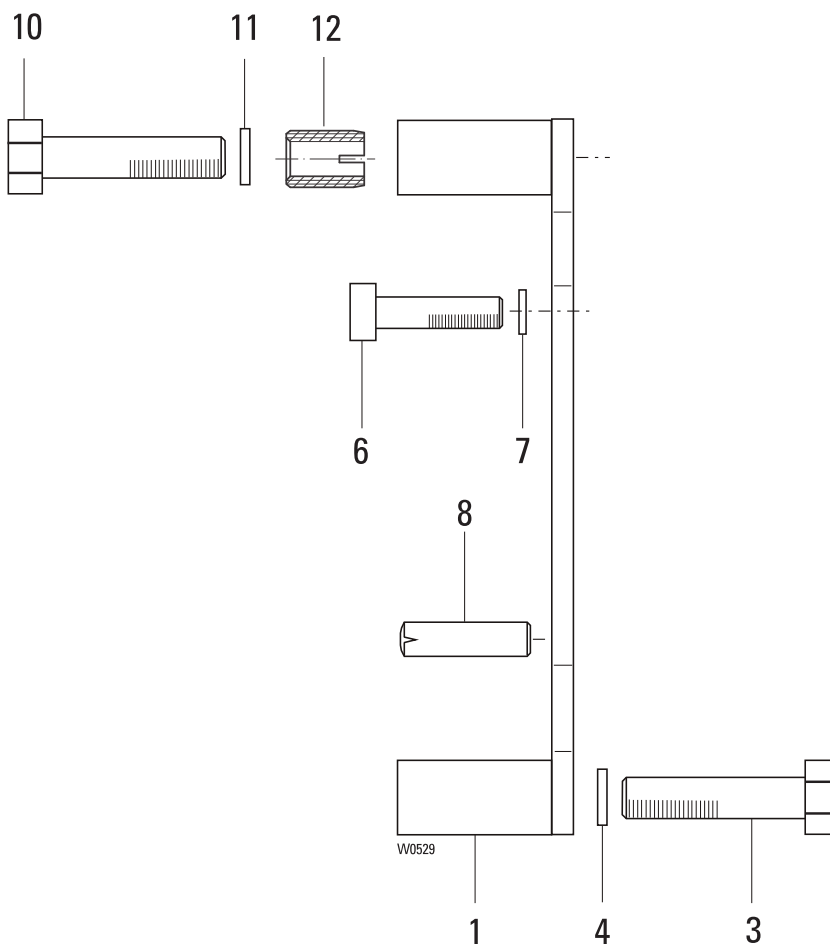

Pos	Teil-Nummer Part-Number	Stück Piece	Beschreibung Description	Benennung	Designation
1	23 270 05 22 0	1	(Pos.3-12)	Dehmomentstütze	Torque support
3	500 208 0	2	M12x65 ISO 4014-8.8	Skt-Schraube	Hexagon head cap screw
4	507 104 0	2	SKM12	Sperrkantscheibe	Lock washer
6	500 148 0	4	M10x25 DIN 912-8.8	Zyl-Schraube	Socket head cap screw
7	506 840 0	4	S10	Sicherungsscheibe	Locking disc
8	504 035 0	2	10m6x28 DIN 7	Zyl-Stift	Pin
10	500 303 0	2	M12x40 ISO 4017	Skt-Schraube	Hexagon head cap screw
11	507 104 0	2	SKM12	Sperrkantscheibe	Lock washer
12	526 000 0	2	M12x22 IN22b	Ensat	Ensat

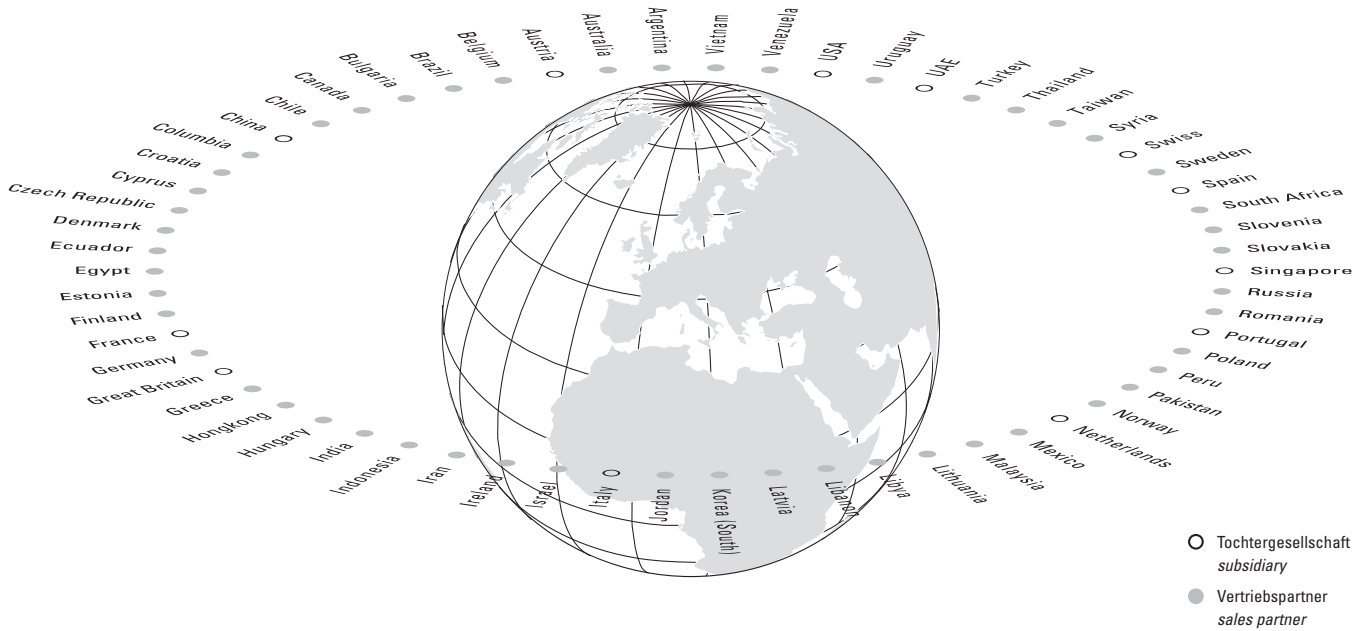

Europe		T	F	E
Austria	Steyregg	+43 732 641111-0	+43 732 641111-33	office@stahlcranes.at
France	Paris	+33 1 39985060	+33 1 34111818	info@stahlcranes.fr
Great Britain	Birmingham	+44 121 7676414	+44 121 7676490	info@stahlcranes.co.uk
Italy	S. Colombano	+39 0185 358391	+39 0185 358219	info@stahlcranes.it
Netherlands	EL Haarlem	+31 23 51252-20	+31 23 51252-23	info@stahlcranes.nl
Portugal	Lissabon	+351 21 44471-61	+351 21 44471-69	ferrometal@ferrometal.pt
Spain	Madrid	+34 91 484-0865	+34 91 490-5143	info@stahlcranes.es
Switzerland	Däniken	+41 62 82513-80	+41 62 82513-81	info@stahlcranes.ch

America/Asia		T	F	E
China	Shanghai	+86 21 6257 2211	+86 21 6254 1907	victor.low@stahlcranes.cn
India	Chennai	+91 44 4352-3955	+91 44 4352-3957	anand@stahlcranes.in
Singapore	Singapore	+65 6271 2220	+65 6377 1555	sales@stahlcranes.sg
U.A.E.	Dubai	+971 4 805-3700	+971 4 805-3701	info@stahlcranes.ae
USA	Charleston, SC	+1 843 767-1951	+1 843 767-4366	sales@stahlcranes.us

Россия ООО "КранШталь" 109451, г.Москва, ул. Верхние поля, д.28
 тел./факс: +7 495 2253788 +7 495 9214517 info@stahlcranes.ru

→ www.kranstahl.ru
 → www.tali-market.ru

→ www.servis-kran.ru
 → www.stahlcranes.ru

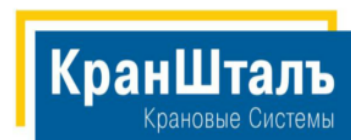

Partner of

