

КранСталь



SH 4



Explosiongeschützte Seilzüge _

↘ DE

Originalteileliste

Explosion-Protected Wire Rope Hoists _

↘ EN

Original parts list

⊕ II 2 G (ATEX) - Zone 1

⊕ II 2 D (ATEX) - Zone 21

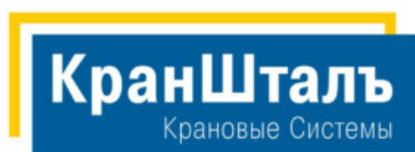

<http://kranstahl.ru>
info@kranstahl.ru

Partner of



+7 (495) 225-37-88



Notizen
Notice

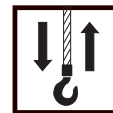

Hubmotor	4	Hoist motor	4
Getriebe	6	Gear	6
Seiltrommel	8	Rope drum	8
Seilauflhängung	10	Rope suspension	10
Hakengeschirr	12	Bottom hook block	12
Hakentraverse	13	Hook traverse	13
Hakenflasche	14	Bottom hook block	14
Gerätekasten	17	Control panel	17
Steuerung	18	Control	18
Steuergerät	18	Control pendant	18
Fahrwerke	19	Trolleys	19
Fahrtriebe	21	Travel drives	21
Drehmomentstütze	29	Torque support	29

Austausch und Reparaturen nur von geschultem Personal ausführen lassen.

Replacement and repairs may only be carried out by trained personnel.

Die Angaben in der Spalte "Benennung" dienen nur internen Vorgängen.

The information in the column "Designation" is only for internal use.

Bitte immer die Fabrik-Nr. des Hebezeuges angeben.

Please always state hoist serial number.



Originalteile
Original parts
SH 4 ex

A4 ex

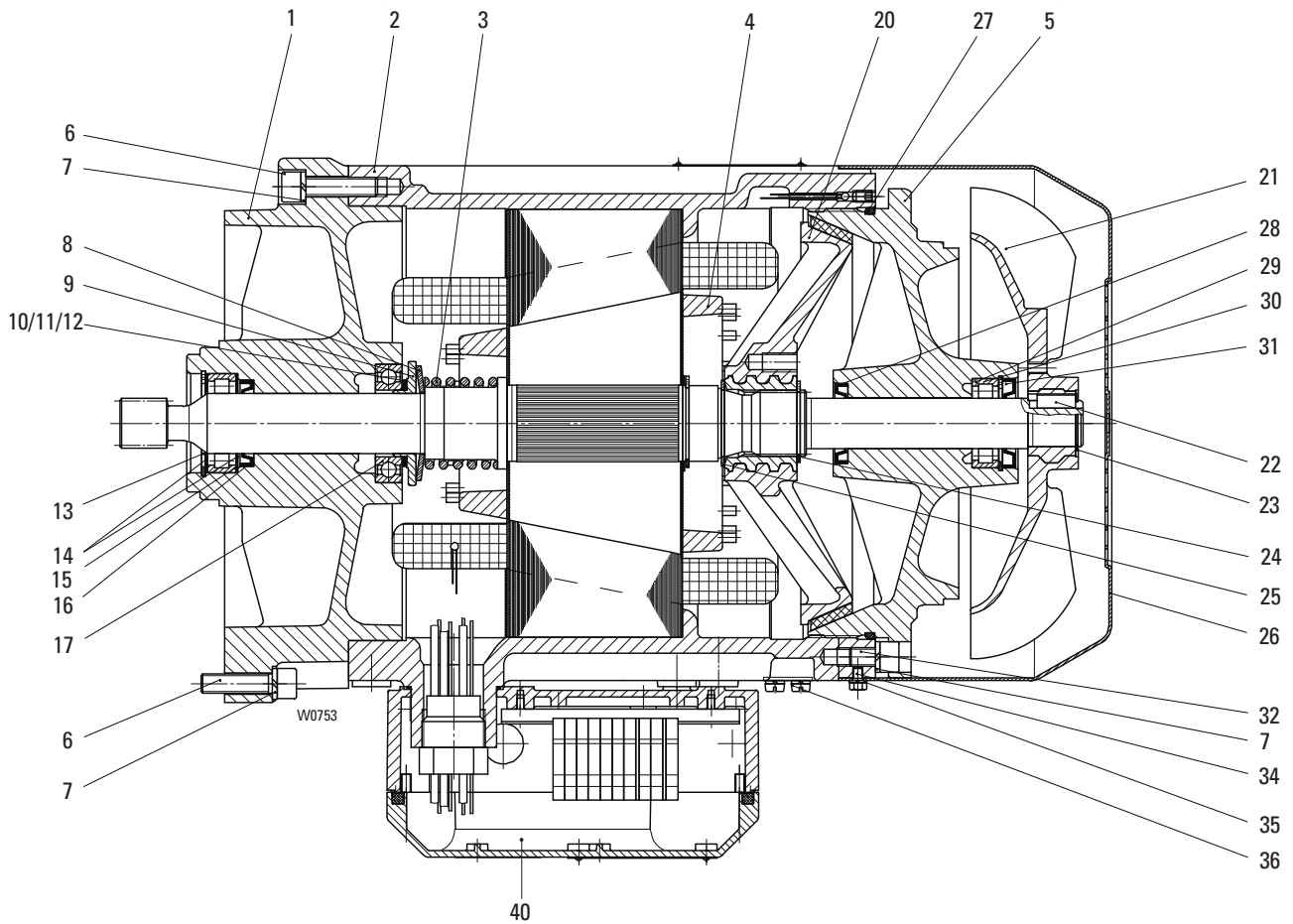

Pos	Teil-Nummer Part-Number	Stück Piece	Beschreibung Description	Benennung Designation
	44 330 47 11 0	1	2/12A4 IIB *1 1)	Motor
	44 330 48 11 0	1	2/12A4 IIC *1 1)	Motor
1	44 331 24 03 0	1	IIB	Motorflansch
	44 331 25 03 0	1	IIC	Motorflange
2	44 330 74 12 9	1	2/12A4 1)	Stator
3	44 331 00 94 0	1		Druckfeder
				Ressure spring
4	44 330 32 13 0	1		Rotor
	44 330 33 13 0	1		Rotor
5	44 330 52 37 0	1	IIB (Pos.28-31)	Motordeckel
	44 330 53 37 0	1	IIC (Pos.28-31)	Motor cover
	44 330 54 37 0	1	IIC 4) (Pos.28-31)	
6	500 149 0	8	M10x40 ISO 4762	Zyl-Schraube
				Socket head cap screw
7	506 904 0	12	10 DIN 7980	Federring
				Spring washer
8	43 331 01 14 0	1	60x32,5x4,35x0,3	Tellerfeder
				Cup spring
9	44 331 20 51 0	1		Abstandsring
				Spacer ring
10	44 331 00 52 0	1	45/35/0,5	Scheibe
				Disc
11	506 825 0	1	DIN 988	Passscheibe
				Ajusting washer
12	44 331 01 52 0	1	35x45x0,345/35/1	Scheibe
				Disc
13	506 107 0	1	52x2 DIN 472	Sicherungsring
				Circlip
14	43 331 02 52 0	1	25/34/1	Scheibe
				Disc
15	560 846 0	1	RNU 205 E	Zyl-Rollenlager
				Roller bearing
16	561 862 0	1	DG 31,5x45x7 W-FP	Wellendichtring
				Shaft seal
17	560 067 0	1	6007-2RS-C3	Rillenkugellager
				Grooved ball bearing
20	44 330 20 18 0	1		Bremsscheibe
				Breake disc
21	44 331 20 15 0	1		Lüfterrad
				Fan wheel
22	537 902 0	1	B8x7x20 DIN 6885	Passfeder
				Key



Pos	Teil-Nummer Part-Number	Stück Piece	Beschreibung Description	Benennung	Designation
23	506 428 0	1	24x1,2	Sicherungsring	Circlip
24	506 099 0	1	35x1,5	Sicherungsring	Circlip
25	44 331 20 74 0	1	45/35,1/1,5	Scheibe	Disc
26	44 331 02 40 0	1		Lüfterhaube	Fan cover
28	1	A27x42x7	Wellendichtring	Shaft seal
29	1	RNU 204 E	Zyl-Rollenlager	Roller bearing
30	1	47x1,75	Sicherungsring	Circlip
31	1		Wellendichtring	Shaft seal
32	500 985 0	4	M10x16	Zyl-Schraube	Socket head cap screw
34	500 419 0	4	M5x8	Skt-Schraube	Hexagon head cap screw
35	506 042 0	4	A5	Federring	Spring washer
36	46 330 70 81 0	1		Erdungsklemme	Earth clamp
40	02 220 20 02 0	1		Anschlusskasten	Terminal box

*1 Bitte angeben: Abtriebswelle Linksschräg: rechtsschräg; geradverzahnt

1) Bitte Betriebsspannung und Frequenz angeben.

2) Ausführung linksschräg

3) Ausführung rechtsschräg

4) hartverchromt

*1 Please state: with output shaft left-handed; right-handed; spur-toothed

1) Please state operating voltage and frequency.

2) Left-hand design

3) Righthand design

4) Hard chrome plated



Originalteile
Original parts
SH 4 ex

Zwischengetriebe / Intermediate gear

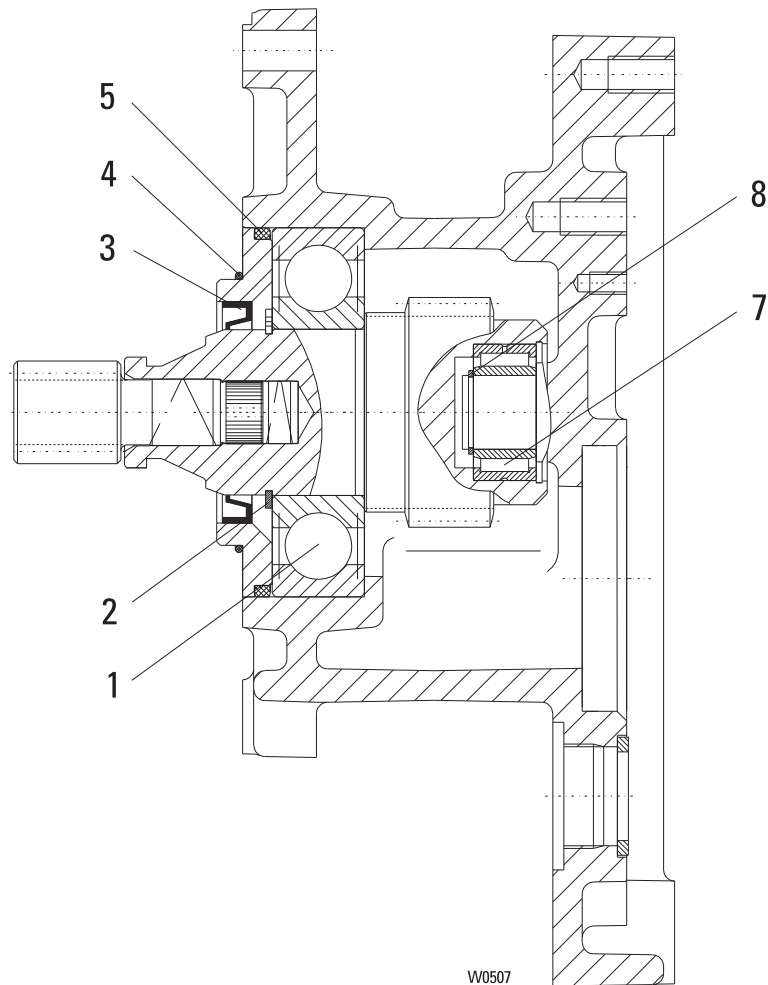

Pos	Teil-Nummer Part-Number	Stück Piece	Beschreibung Description	Benennung Designation	Designation
	24 270 33 30 0	1	SH 40..-8	Zwischengetriebe	Intermediate gear
		1	SH 40..-10		
	24 270 34 30 0	1	SH 40..-12		
		1	SH 40..-16		
	24 270 35 30 0	1	SH 40..-20		
		1	SH 40..-25		
	24 270 36 30 0	1	SH 40..-32		
		1	SH 40..-40		
1	560 829 0	1	6309-27	Rillenkugellager	Grooved ball bearing
2	506 101 0	1	45x1,75	Sicherungsring	Locking ring
3	561 026 0	1	45x60x8 NB	Wellendichtring	Shaft seal
4	515 953 0	1	70x2	Runddichtring	Round sealing ring
5	515 970 0	1	90x4	Runddichtring	Round sealing ring
7	560 995 0	1	NA 4904	Nadellager	needle roller bearing
8	507 122 0	1	SW 20	Sprengring	Circlip

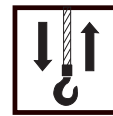

Getriebe/gear

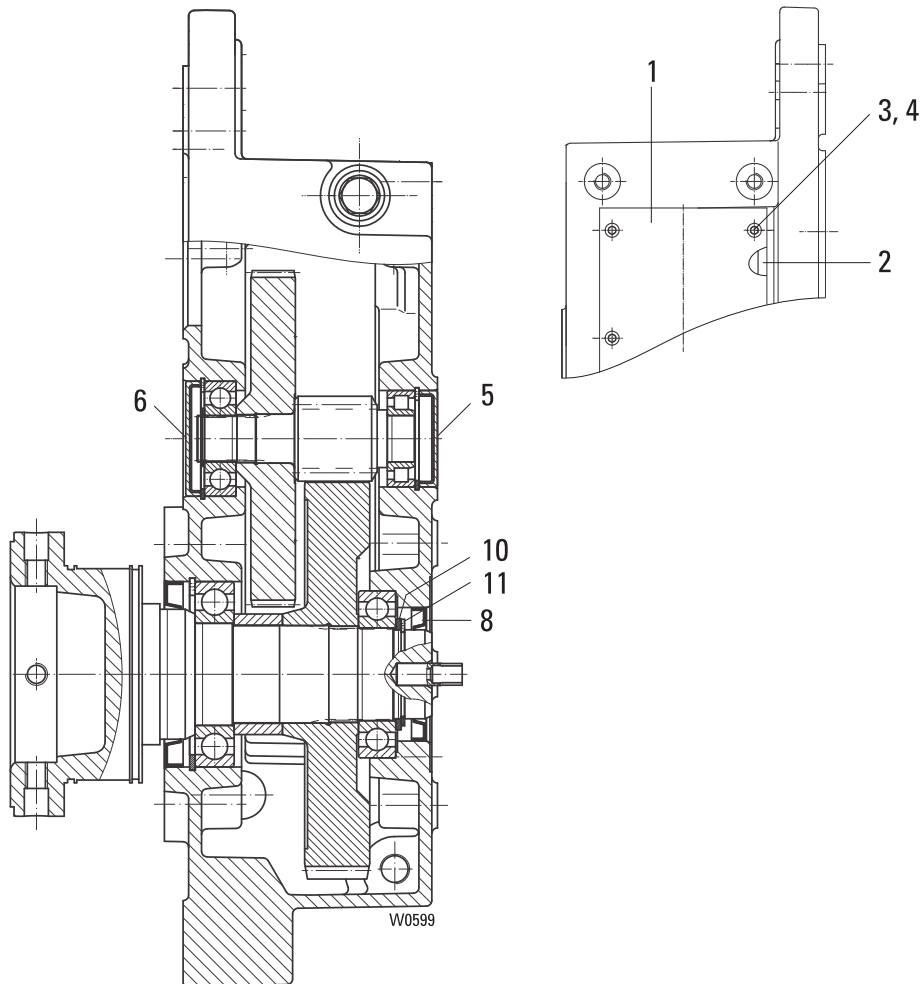

Pos	Teil-Nummer Part-Number	Stück Piece	Beschreibung Description	Benennung	Designation
	24 270 02 30 0	1	SH 40..-8 1)	Getriebe	Gear
	24 270 03 30 0	1	SH 40..-10 1)		
	24 270 04 30 0	1	SH 40..-12 1)		
	24 270 05 30 0	1	SH 40..-16 1)		
	24 270 10 30 0	1	SH 40..-20 1)		
	24 270 11 30 0	1	SH 40..-25 1)		
	24 270 12 30 0	1	SH 40..-32 1)		
	24 270 14 30 0	1	SH 40..-40 1)		
1	24 273 00 96 0	1		Deckel	Cover
2	24 273 00 95 0	1		Dichtung	Seal
3	500 810 0	8	M6x16	Zyl-Schraube	Socket head cap screw
4	506 838 0	8	S6	Sicherungsscheibe	Locking disc
5	518 037 0	1	52x10	Verschlusskappe	End cap
6	518 034 0	1	62x8	Verschlusskappe	End cap
8	561 020 0	1	48x72x8	Wellendichtring	Shaft seal
10	506 153 0	1	S48x60x3	Stützscheibe	Supporting ring
11	506 076 0	1	48x1,75	Sicherungsring	Locking ring

1) Getriebe nur komplett lieferbar.
Ohne Getriebeöl: Erforderliche Menge siehe Betriebsanleitung

1) Gear only available as complete unit.
Without gear oil: amount required see operating instruction.



Originalteile
Original parts
SH 4 ex

Seiltrommel/rope drum

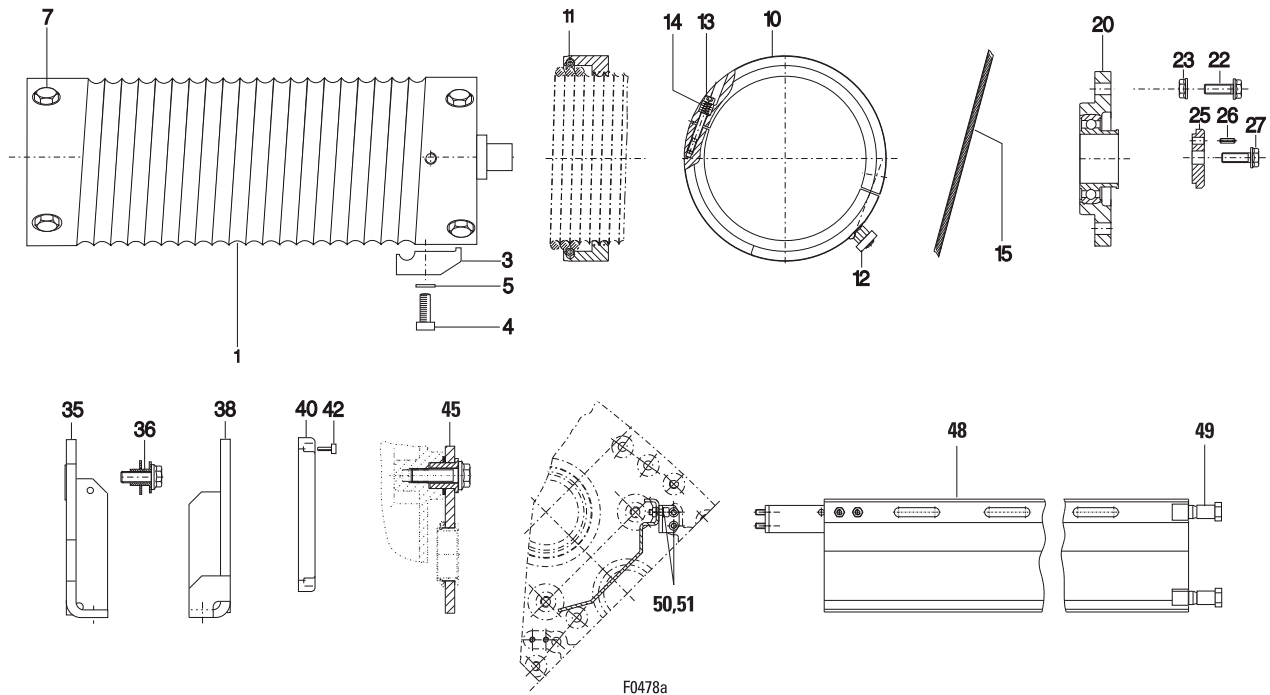

Pos	Teil-Nummer Part-Number	Stück Piece	Beschreibung Description			Benennung	Designation
1	04 434 00 04 0	1	L2	1)	/1	Seiltrommel	Rope drum
	04 434 01 04 0	1	L3	1)	/1		
1	04 434 04 04 0	1	L2	1)	/2-	Seiltrommel	Rope drum
	04 434 05 04 0	1	L3	1)	/2-		
3	04 430 00 46 0	3	D8,5-9	(Pos.4+5)		Klemmplatte Zyl-Schraube Sicherungsscheibe	Clamping plate Socket head cap screw Locking disc
4	500 290 0	3	M10x20	DIN 6912-8.8			
5	506 840 0	3	S 10				
3	04 430 01 46 0	6	D6,5-7	(Pos.4+5)		Klemmplatte Zyl-Schraube Sicherungsscheibe	Clamping plate Socket head cap screw Locking disc
4	500 290 0	6	M10x20	DIN 6912-8.8			
5	506 840 0	6	S 10				
7	500 015 0	4	M12x35	DIN 7968		Skt-Paßschraube	Screw
10	04 430 00 43 0	1	D8,5-9	/1	2)	Seilführungsring	Rope guide
	04 430 01 43 0	1	D6,5-7	/2-	2)		
	04 430 02 43 0	1	D6,5-7	/2-	3)		
11	04 434 00 94 0	1				Zugfeder	Tension spring
12	04 430 01 47 0	1				Führungsteil	Guide part
13	21 334 00 90 0	2				Schraube	Screw
14	22 334 01 94 0	1				Druckfeder	Pressure spring

- 1) Pos.20 immer mitbestellen.
- 2) Seilführung Linksgewinde
- 3) Seilführung Rechtsgewinde

- 1) Always included item 20 in order
- 2) Rope guide left thread
- 3) Rope guide right thread

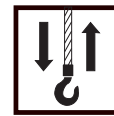

Seiltrommel/rope drum

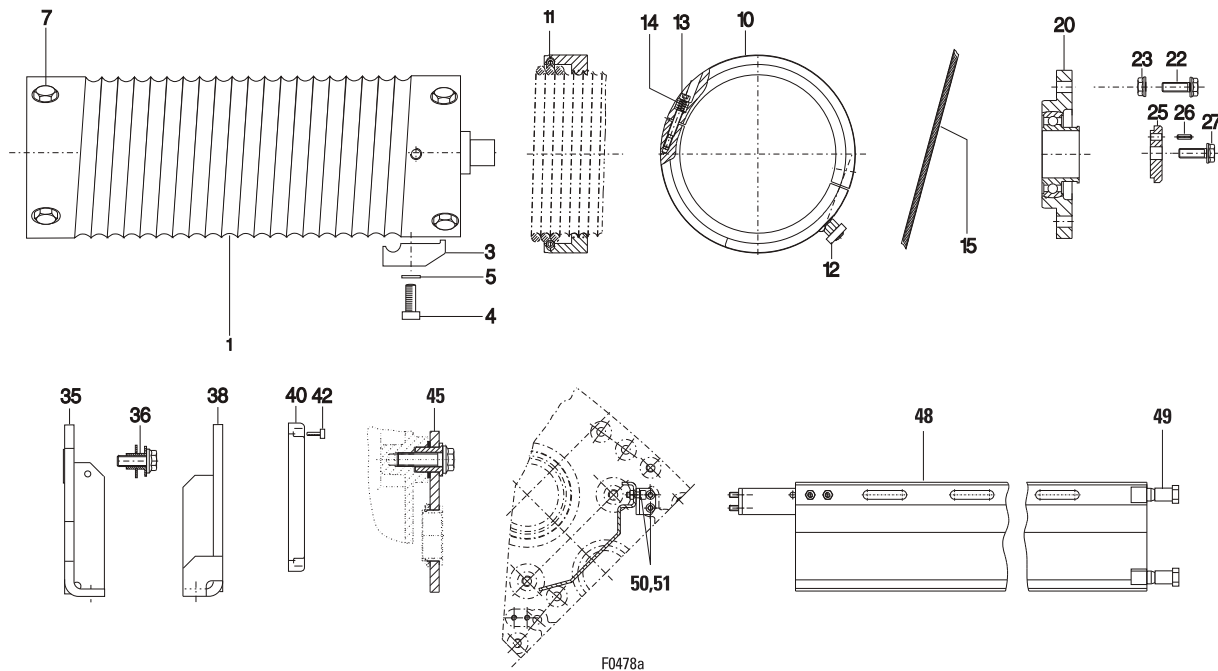

Pos	Teil-Nummer Part-Number	Stück Piece	Beschreibung Description	Benennung	Designation
15			4)	Drahtseil	Wire rope
20	560 026 0	1	INA PME 30	Flanschlager	Flange bearing
22	501 117 0	4	M10x30	Sicherungsschraube	Locking screw
23	507 115 0	4	M10	Sicherungsmutter	Locking nut
25	04 432 00 52 0	1		Haltescheibe	Holding disc
26	504 990 0	1	5x10	Spannstift	Clamping sleeve
27	501 104 0	1	M10x20-10	Sicherungsschraube	Locking screw
35	04 432 04 01 0	1		Traglech Getriebeseite	Support plate gear side
	04 432 05 01 0	1	5)		
	04 432 13 01 0	1	6)		
36	04 430 02 26 0	2	1/1	Bundbuchse	Bushing
38	04 432 06 01 0	1		Traglech Lagerseite	Support plate bearing side
	04 432 07 01 0	1	5)		
	04 432 00 40 0	1	6)		
40	505 012 0	4	EM6x16	Abschlußhaube	End cover
42				Schraube	Screw
45	04 430 04 28 0	1		Lagerblech	Bearing plate
48	04 430 02 22 0	1	L2	Fettwanne	Grease box
	04 430 03 22 0	1	L3		
49	04 432 00 90 0	2		Schraube	Screw
50	500 233 0	4	M6x16	Zyl.-Schraube	Socket head cap screw
51	506 838 0	4	S6	Sicherungsscheibe	Lock washer
					ISO 4762

4) Siehe Datenblatt
5) Seilzug stehend stationär
6) Seilzug hängend stationär

4) See data sheet
5) Stationary wire rope hoist, upright
6) Stationary wire rope hoist, suspended



Seilauflhängung/rope suspension

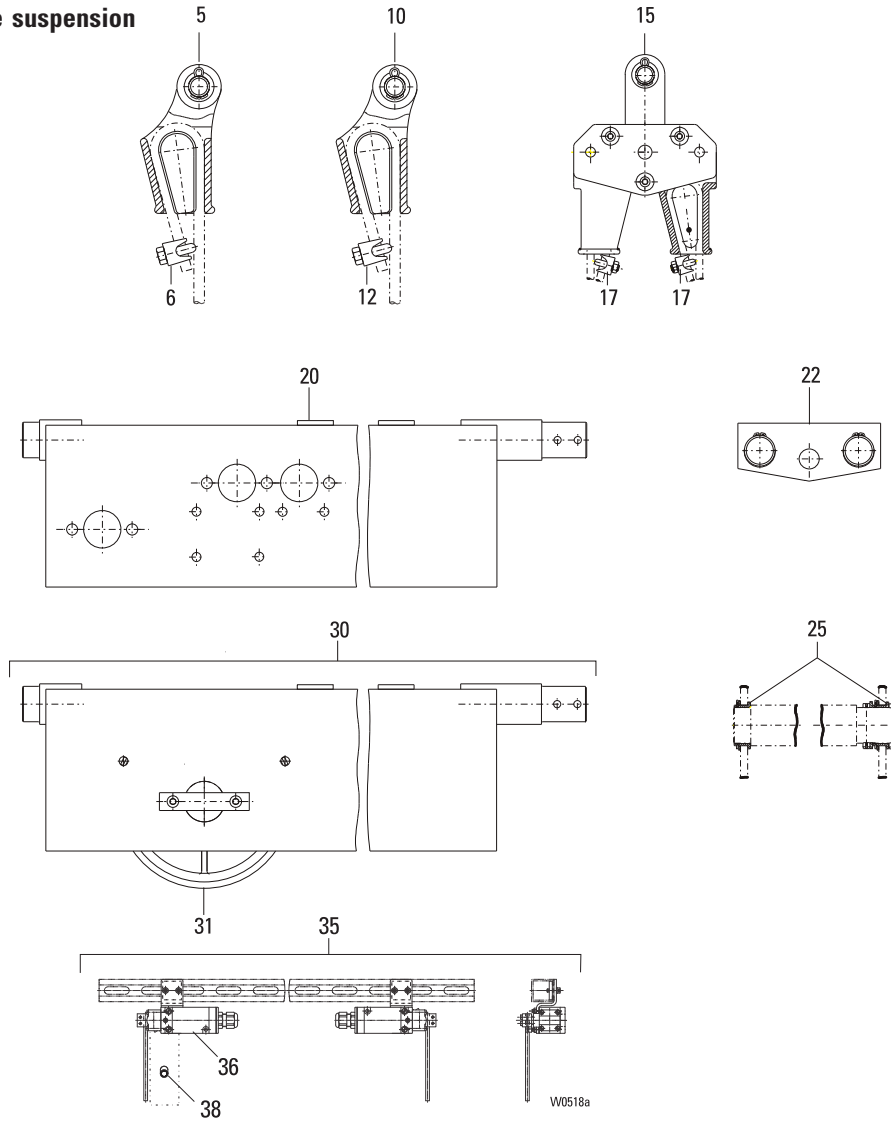

Pos	Teil-Nummer Part-Number	Stück Piece	Beschreibung Description		Benennung	Designation
5	04 430 02 48 0	1	D-7mm	(Pos.6)	Keilendklemme	Clamp
6	517 005 0	1	Gr.8		Drahtseilklemme	Wire rope clamp
10	04 430 01 48 0	1	D-8,5mm, 9mm	(Pos.12)	Keilendklemme	Clamp
12	517 006 0	1	Gr.10		Drahtseilklemme	Wire rope clamp
15	04 430 00 23 0	1		(Pos.17)	Wippe	Rocking bar
17	517 005 0	2	Gr.8		Drahtseilklemme	Wire rope clamp
20	04 430 01 28 0	1	L2	1)	Aufhängertraverse	Suspension traverse
	04 430 02 28 0	1	L3	1)		
22	04 430 00 28 0			x)	Aufhängung	Suspension
25	04 430 01 26 0	1			Bundbuchse	Bushing
30	04 430 00 27 0	1	L2	1) (Pos.31)	Umlenkung	Deflection cross bar
	04 430 01 27 0	1	L3	1) (Pos.31)		
31	03 330 20 53 0	1	ø160 mm		Seilrolle	Rope pulley
35	04 430 20 85 0	1		1)	Endschalteranbau	Limit switch attachment
36	04 430 23 85 0	2			Ex-Positionsschalter	Limit switch
38	503 020 0	1	M8x1x80-14Hvz	DIN427	Schaftschraube	Screw

1) stationär
x) Stückzahl nach Bedarf

1) stationary
x) Quantity as required

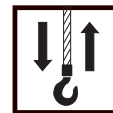

Seilauflhängung/rope suspension

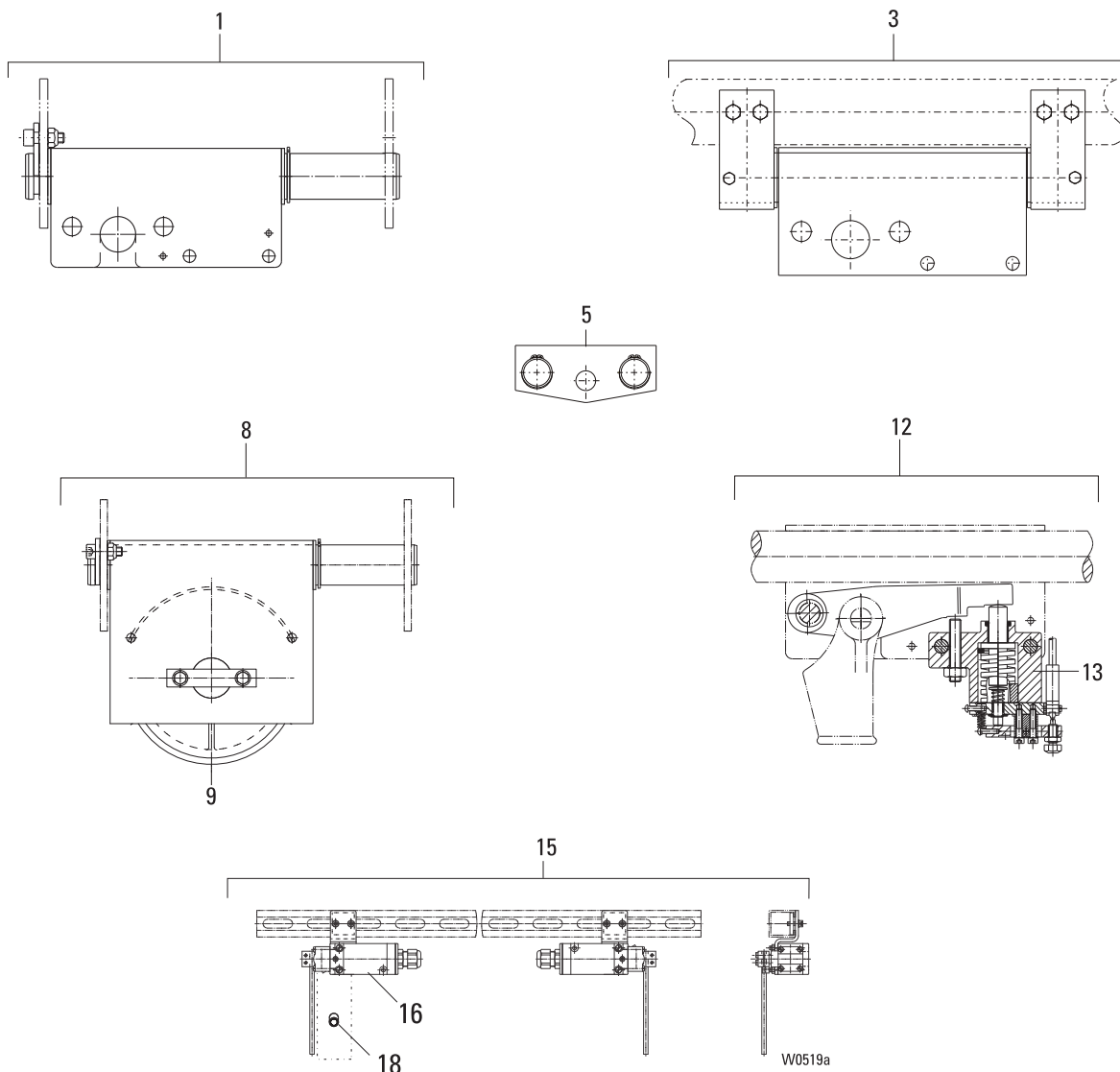

Pos	Teil-Nummer Part-Number	Stück Piece	Beschreibung Description		Benennung	Designation
1	04 430 07 28 0	1	2/1	1)	Aufhängung	Suspension
3	04 430 06 28 0	1	4/1	1)	Aufhängung	Suspension
5	04 430 00 28 0	1			Aufhängung	Suspension
8	04 430 04 27 0	1		1) (Pos.9)	Umlenkung	Deflection cross bar
9	03 330 20 53 0	1	D160		Seilrolle	Rope pulley
12	04 430 06 94 0	1	800 daN	(Pos.13)	Lastsensor	Load sensor
	04 430 07 94 0	1	1000 daN			
	04 430 08 94 0	1	1250 daN			
	04 430 09 94 0	1	1600 daN			
13	04 430 03 84 0	1	800 daN		Messeinheit	Measuring unit
	04 430 04 84 0	1	1000 daN			
	04 430 05 84 0	1	1250 daN			
	04 430 06 84 0	1	1600 daN			
15	04 430 20 85 0	1		1) (Pos.16)	Endschalteranbau	Limit switch attachment
16	04 430 23 85 0	2			Ex-Positionsschalter	Limit switch
18	503 020 0	1	M8x1x80-14Hvz	DIN 427	Schaftschraube	Screw



Originalteile
Original parts
SH 4 ex

H110-1

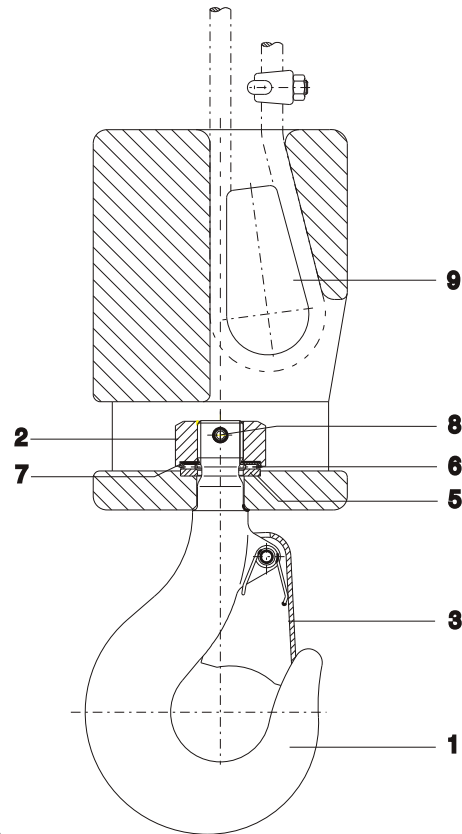
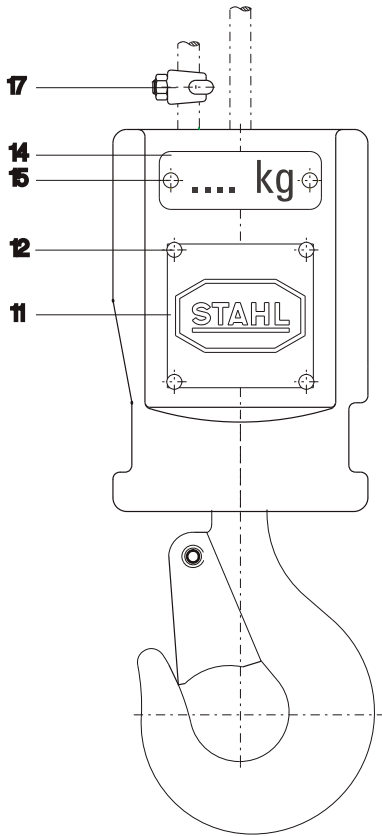

F076

Bitte immer die Fabrik-Nr. des Hebezeuges angeben.

Please always state hoist serial number.



T130-2

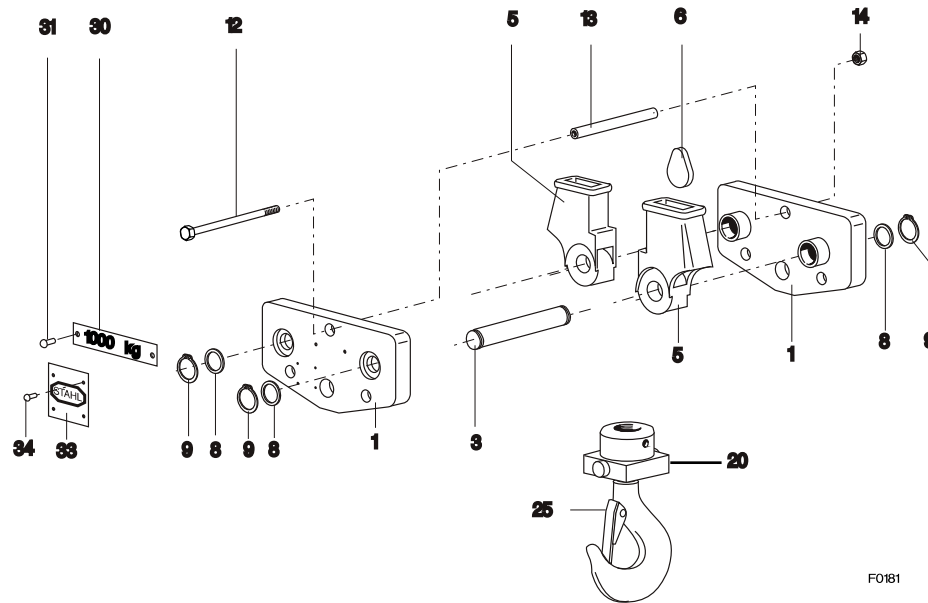

F0181

Bitte immer die Fabrik-Nr. des Hebezeuges angeben.

Please always state hoist serial number.



Originalteile
Original parts
SH 4 ex

H164-2

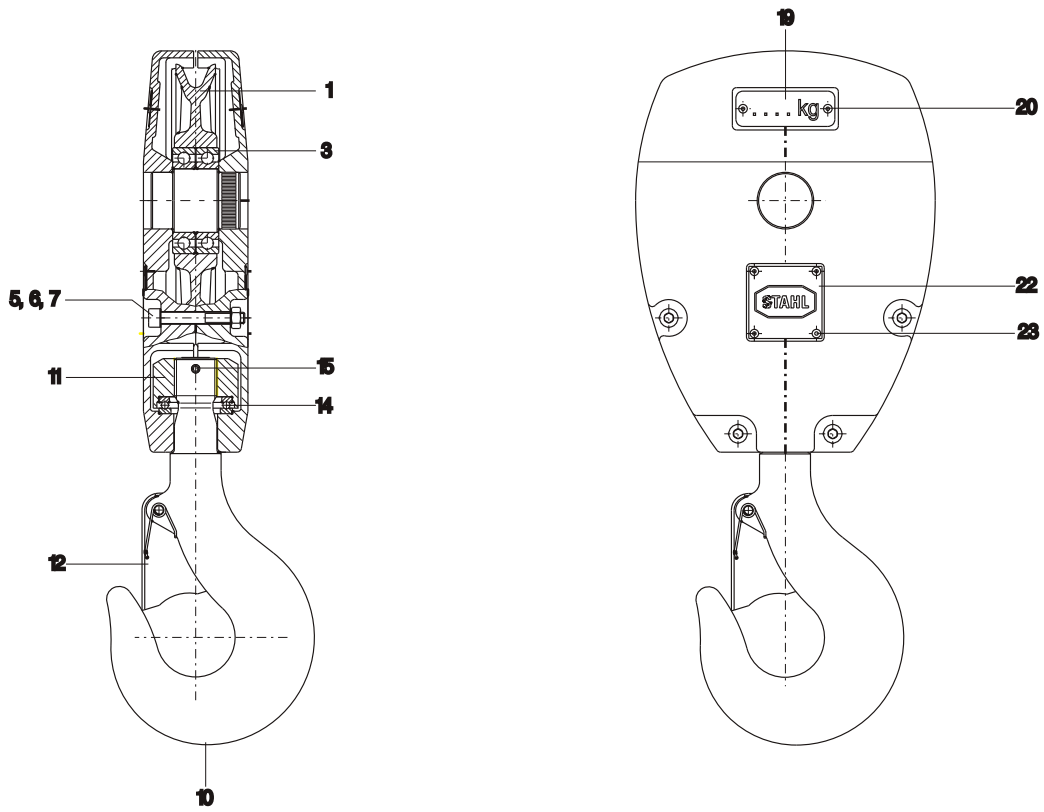

F0804a

Bitte immer die Fabrik-Nr. des Hebezeuges angeben.

Please always state hoist serial number.

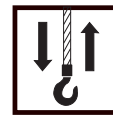

H125-4



Рис. 2

Bitte immer die Fabrik-Nr. des Hebezeuges angeben.

Please always state hoist serial number.

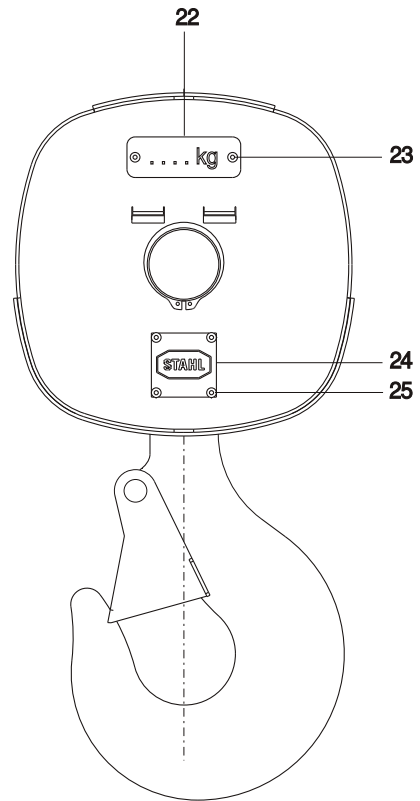
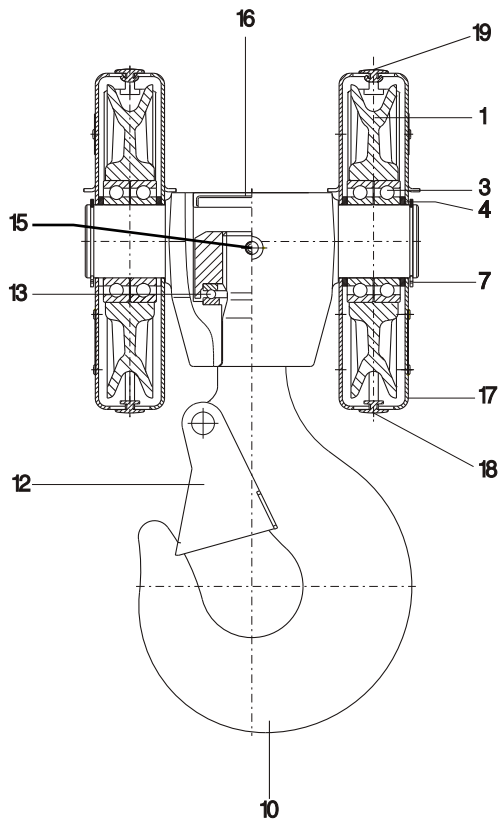

Originalteile
Original parts
SH 4 ex

H162-4

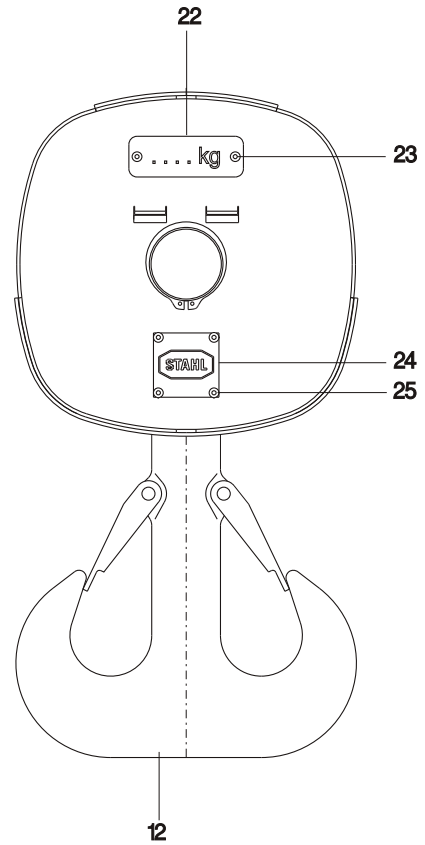
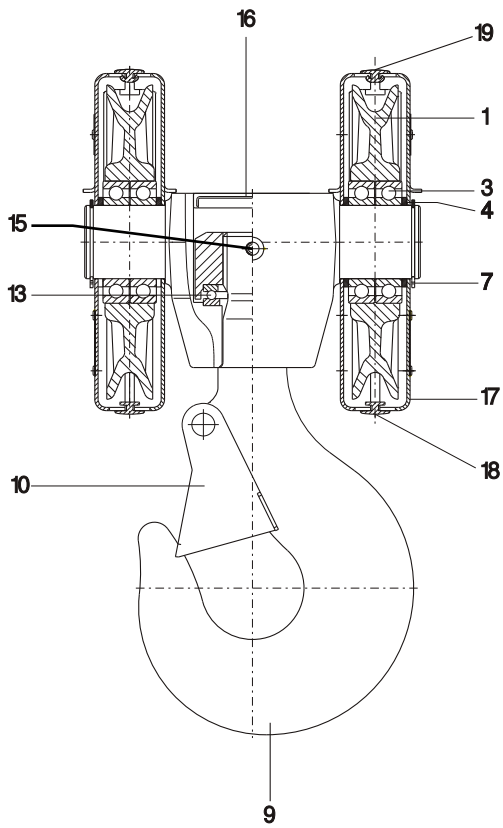

F027

Bitte immer die Fabrik-Nr. des Hebezeuges angeben.

Please always state hoist serial number.

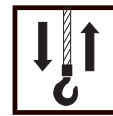

K-A 3. ex

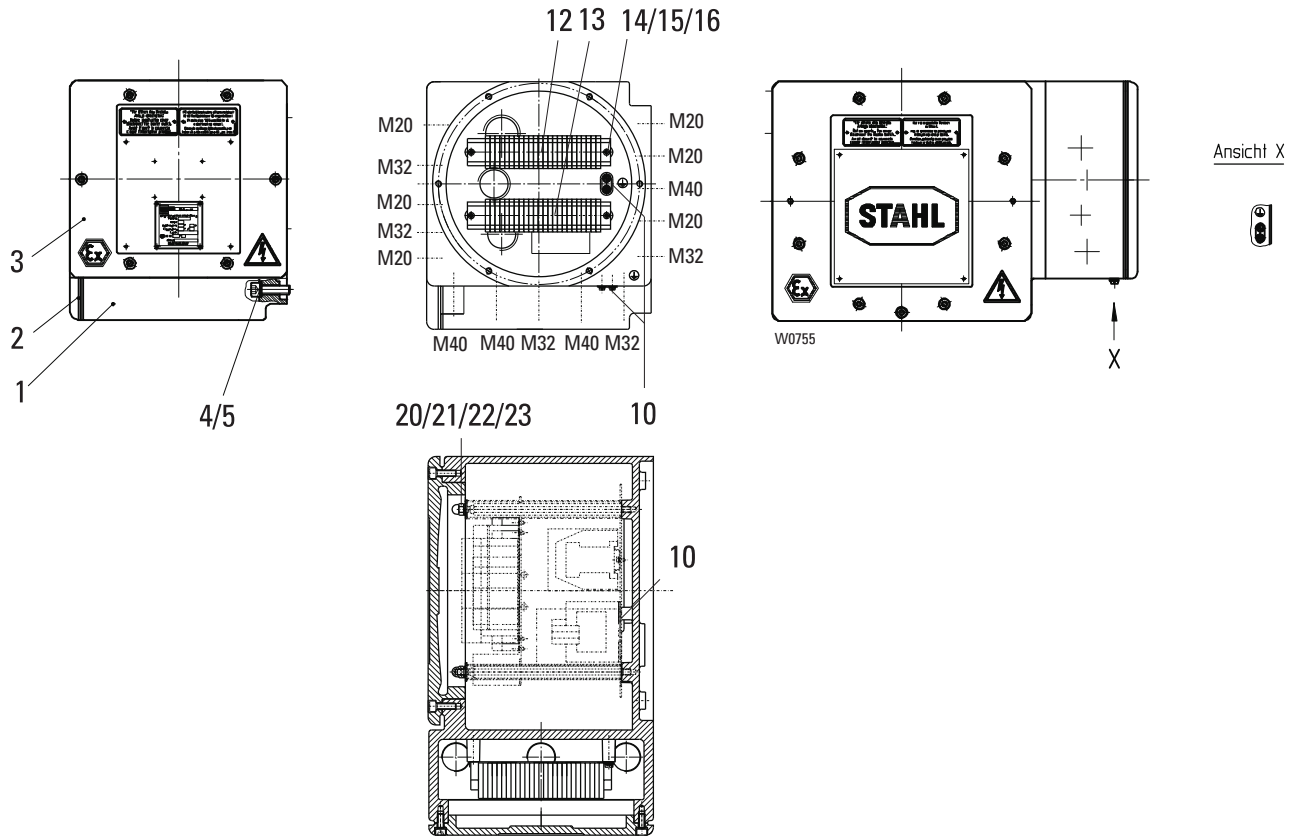

Pos	Teil-Nummer Part-Number	Stück Piece	Beschreibung Description	Benennung	Designation
1	04 439 01 20 0	1	IIB	Gerätekasten	Terminal box
1	04 439 02 20 0	1	IIC		
2	04 430 71 97 0	1	d280	Kastendeckel	Box cover
3	04 430 80 97 0	1	e240	Kastendeckel	Box cover
4	500 184 0	3	M12x40	Zyl.-Schraube	Socket head cap screw
5	506 841 0	3	S12	Sicherungsscheibe	Lock washer
10	46 330 70 81 0	3		Erdungsklemme	Earth clamp
12	03 430 41 89 0	1		Klemmleiste	Terminal strip
13	03 430 39 89 0	1		Klemmleiste	Terminal strip
14	502 051 0	4	M4x8	Zyl.-Schraube	Socket head cap screw
15	506 374 0	4	4	Federring	Spring washer
16	506 062 0	4	4,3	Scheibe	Disc
20	506 859 0	2	8,4	Scheibe	Disc
21	506 839 0	2	S8	Sicherungsscheibe	Lock washer
22	506 924 0	2	M8	Hutmutter	Cap nut
23	44 329 20 92 0	2		Führungsbolzen	Guiding bolt



Originalteile
Original parts
SH 4 ex

Standard -Steuerung / standard control
400V / 50Hz

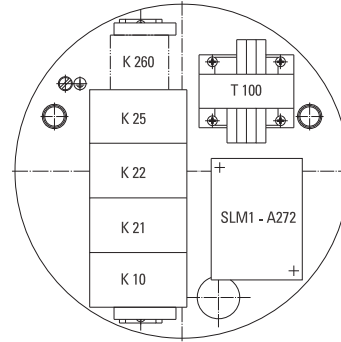
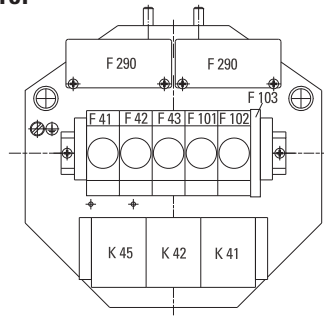

W0521

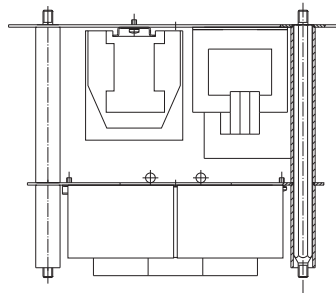

Geräteliste / parts list

Motor 12/2 A4 ex

Siehe auftragsbezogene Geräteliste in der Seilzug- Dokumentation
See parts list in individual wire rope hoist documentation.

Standardsteuergerät / Standard control switch

Typ Type	Teil-Nummer Part-Number
SWH 5102-061 ex	15 390 80 20 9
SWH 5106-061 ex	15 390 79 20 9
SWH 5202-062 ex	15 390 78 20 9
SWH 5206-062 ex	15 390 77 20 9

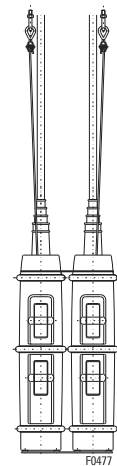

F0477

Sondersteuergeräte: Bitte Typ angeben.

Special control switches: Please state type.

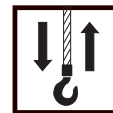

KE-S4

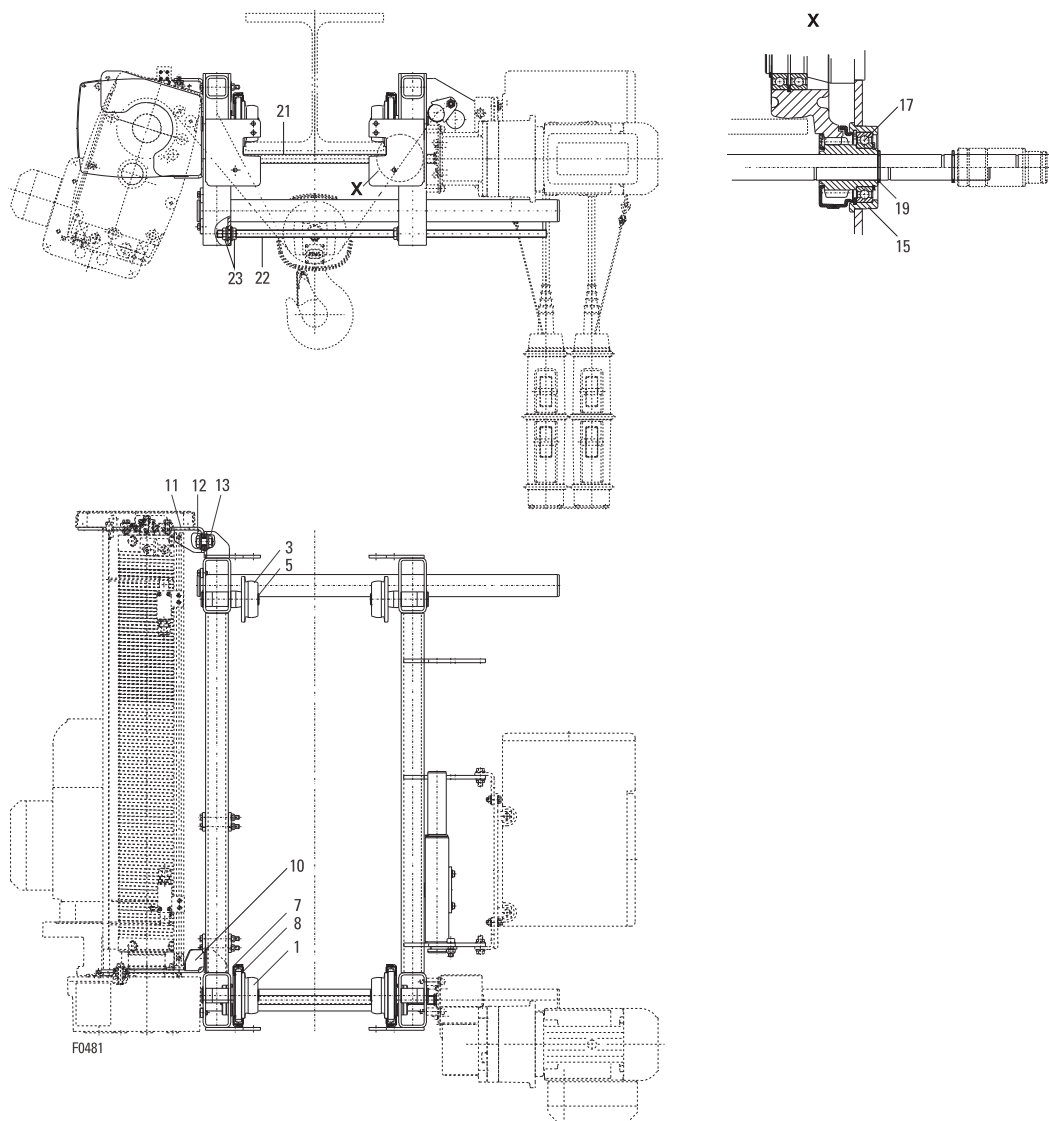

Pos	Teil-Nummer Part-Number	Stück Piece	Beschreibung Description	Benennung	Designation	
1	04 250 04 40 0	2	A100	L4/3	Laufrolle	Wheel
3	04 250 03 41 0	2	B100	L4/3	Laufrolle	Wheel
5	506 098 0	4	30x1,5	DIN 471	Sicherungsring	Locking ring
7	04 254 03 40 0	2			Laufrollenabdeckung	Wheel cover
8	04 254 04 40 0	2			Laufrollenabdeckung	Wheel cover
10	04 432 08 01 0	1			Tragblech	Support plate
11	04 432 09 01 0	1				
12	501 033 0	4	M16x40-10		Sicherungsschraube	Locking screw
13	507 841 0	4	M16		Sicherungsmutter	Locking nut
15	21 270 01 39 0	2		(Pos.17)	Flanschlager	Flange bearing
17	560 936 0	2	6006-2Z	DIN 625	Rillenkugellager	Grooved ball bearing
19	507 098 0	2	20x1,75	DIN 471	Sicherungsring	Locking ring
21	21 273 11 60 0	1		1)	Durchtriebswelle	Drive shaft
	21 273 08 60 0	1		1)		
	21 273 12 60 0	1		1)		
	21 273 13 60 0	1		1)		
22	025 002 9	2	M16x720	DIN 976-8.8	Gewindebolzen	Threaded bolt
23	507 841 0	8	M16		Sicherungsmutter	Locking nut

1) Flanschbreite

1) Flange width



Originalteile
Original parts
SH 4 ex

OE-S04

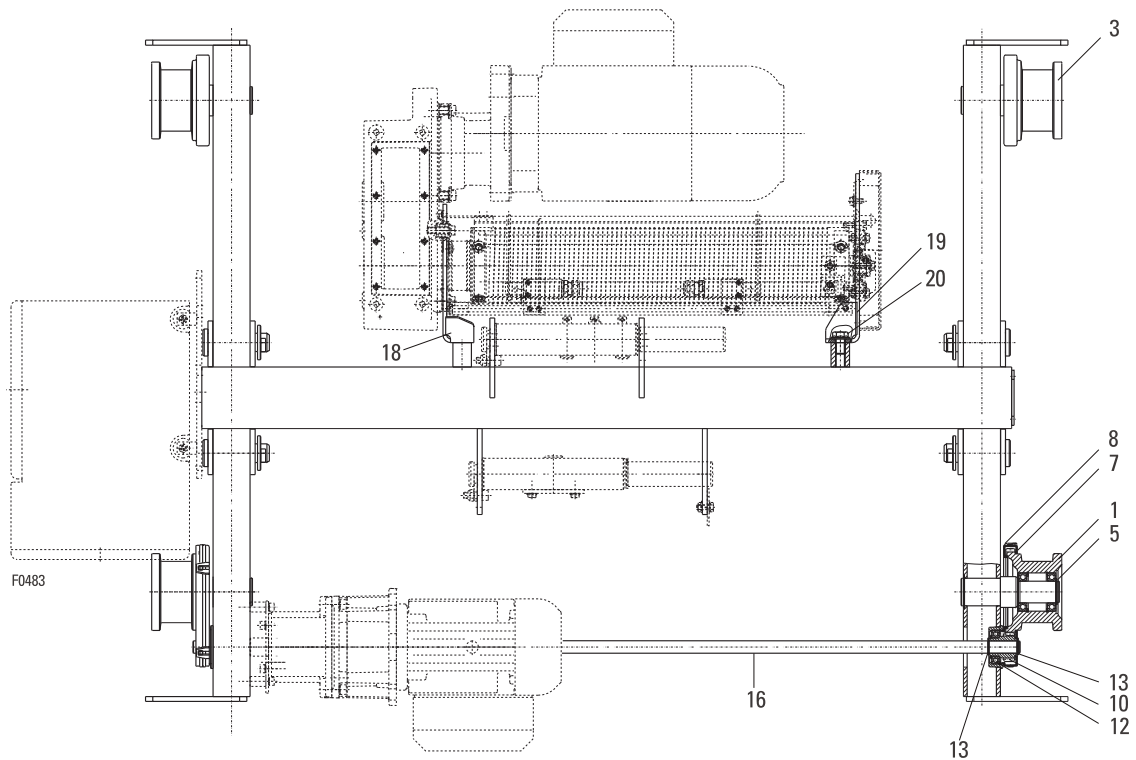

Pos	Teil-Nummer Part-Number	Stück Piece	Beschreibung Description		Benennung	Designation
1	24 250 00 40 0	2	A100	1) 40 mm	Laufрад	Wheel
	24 250 01 40 0	2		1) 50 mm		
3	24 250 00 41 0	2	B100	1) 40 mm	Laufрад	Wheel
	24 250 01 41 0	2		1) 50 mm		
5	506 099 0	4	35x1,5	DIN 471	Sicherungsring	Locking ring
7	04 254 03 40 0	2			Laufrollenabdeckung	Wheel cover
8	04 254 04 40 0	2			Laufrollenabdeckung	Wheel cover
10	21 270 01 39 0	2		(Pos.12)	Flanschlager	Flange bearing
12	560 936 0	2	6006-2Z	DIN 625	Rillenkugellager	Grooved ball bearing
13	507 098 0	2	20x1,75	DIN471	Sicherungsring	Locking ring
16	21 273 05 60 0	1		2) 1250 mm	Durchtriebswelle	Drive shaft
	21 273 03 60 0	1		2) 1400 mm		
	21 273 04 60 0	1		2) 2240 mm		
18	04 432 08 01 0	1			Tragblech Getriebeseite	Support plate gear side
19	04 432 09 01 0	1			Tragblech Lagerseite	Support plate bearing side
20	501 107 0	4	M16x24-10		Sicherungsschraube	Locking screw

1) Schienenbreite
2) Spurweite

1) Rail width
2) Track gauge

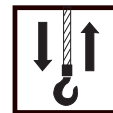

A05 ex
SF 17 ... 503

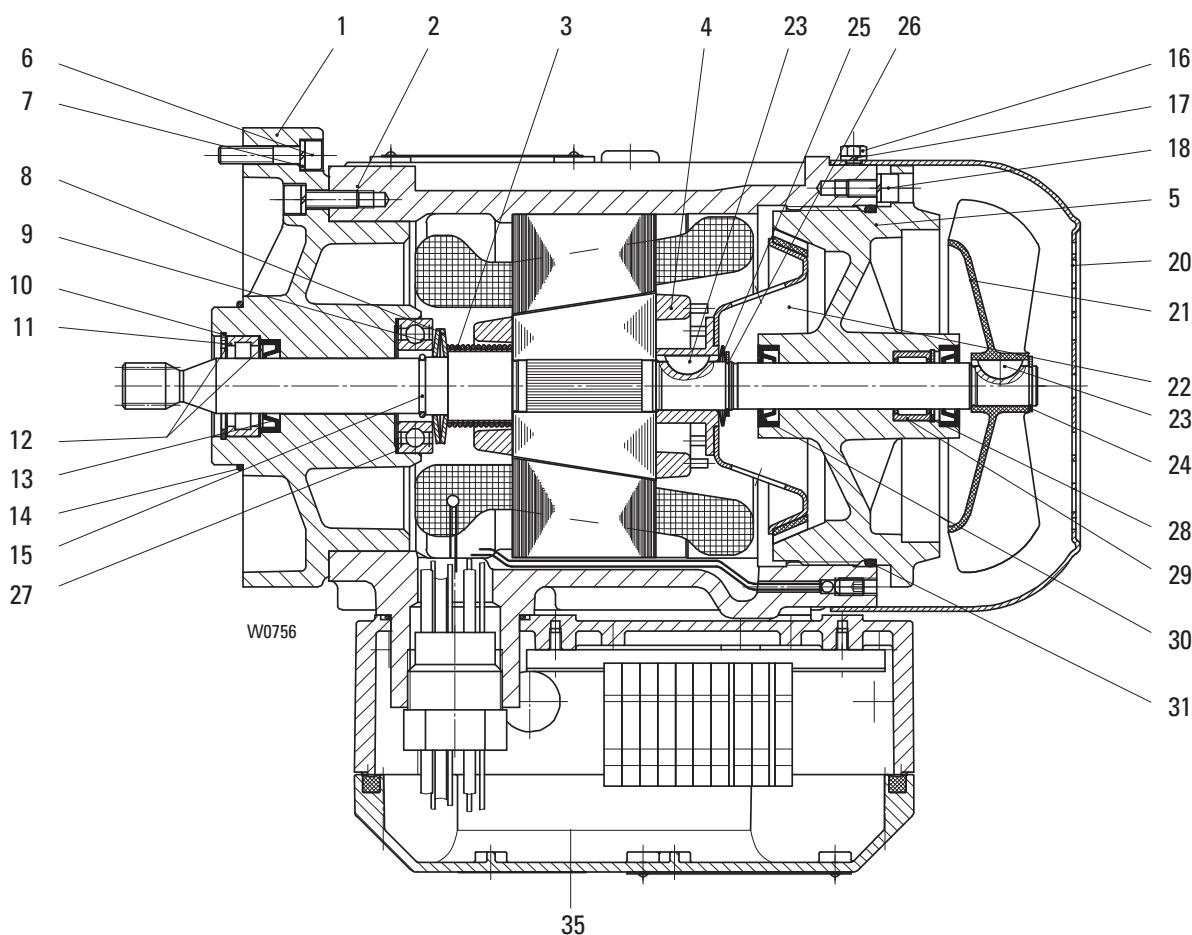

Pos	Teil-Nummer Part-Number	Stück Piece	Beschreibung Description	Benennung Designation
	35 330 56 11 0	1	2/8A05 IIB	Motor
	35 330 57 11 0	1	2/8A05 IIC	Motor
1	35 331 23 03 0	1	IIB	Motorflansch
	35 331 24 03 0	1	IIC	Motorflansch
2	35 330 77 14 9	1	1)	Stator
3	33 331 20 94 0	1		Druckfeder
4	35 330 28 13 0	1		Rotor
5	35 330 05 37 0	1	IIB	Motordeckel
	35 330 04 37 0	1	IIC	Motordeckel
	35 330 06 37 0	1	2)	Motordeckel
6	500 976 0	8	M6X30	Zyl.-Schraube
7	506 335 0	8	6	Federring
8	562 901 0	2	40x20,4x2,65x1,5	Tellerfeder
9	560 951 0	1	6005-2RS	Rillenkugellager
10	506 261 0	1	35x1,5	Sicherungsring
11	506 843 0	1	RNU202E	Zyl.-Rollenlager
12	506 889 0	2	25x35x0,3	Passscheibe
13	561 893 0	1	A19x32x7	Wellendichtring
14	515 946 0	1	55x2	Runddichtring
15	507 836 0	1	A20	Spreng ring
16	500 419 0	4	M5x8	Skt-Schraube
17	506 900 0	4	5	Federring
18	500 230 0	4	M6x12	Zyl.-Schraube
20	35 331 22 40 0	1		Lüfterhaube
21	576 033 0	1	V71 R/14	Lüfterrad

1) Bitte Betriebsspannung und Frequenz angeben.
2) hartverchromt

1) Please state operating voltage and frequency.
2) Hard chrome plated



Originalteile
Original parts
SH 4 ex

A05 ex
SF 17 ... 503

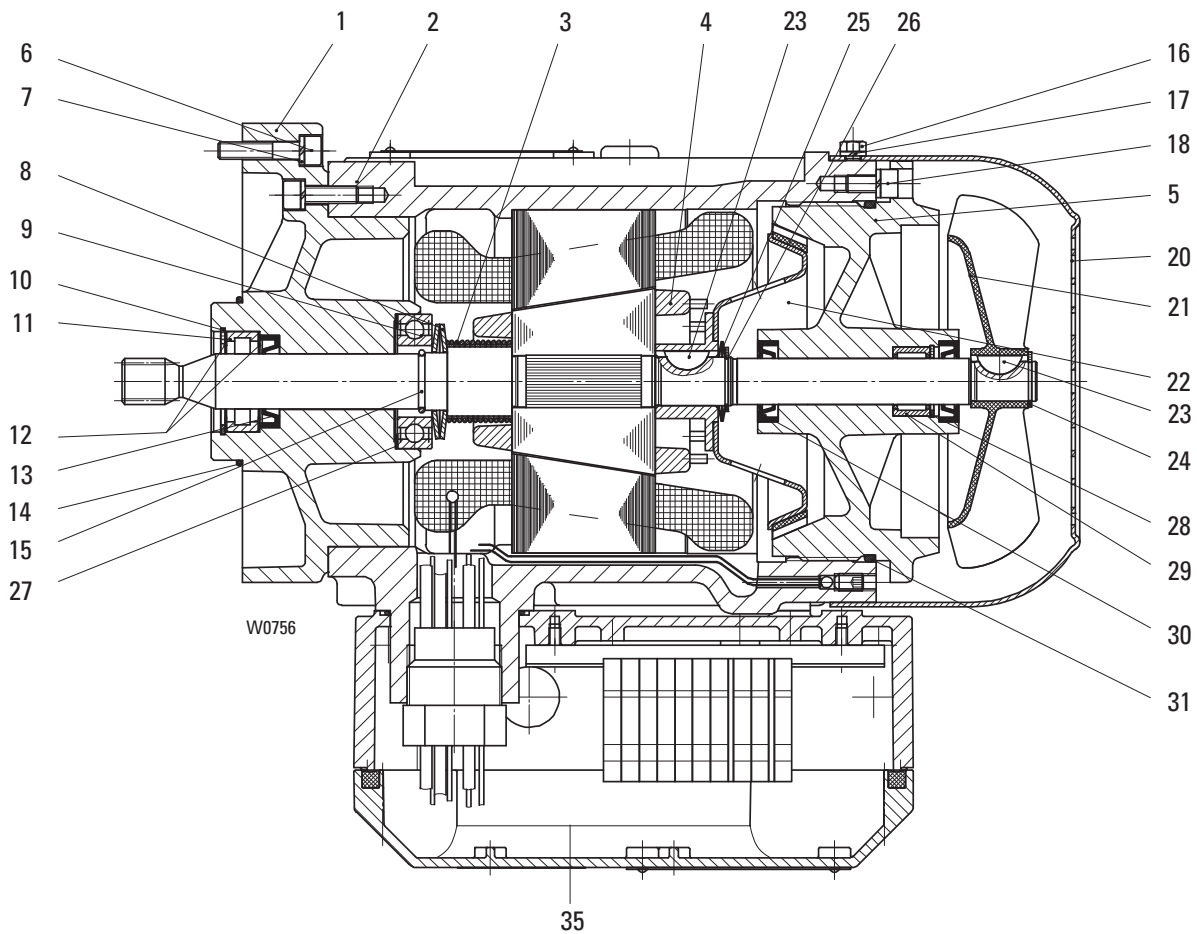

Pos	Teil-Nummer Part-Number	Stück Piece	Beschreibung Description	Benennung	Designation
22	35 330 20 18 0	1		Bremsscheibe	Brake disc
23	537 936 0	2	5x6,5 DIN 6888	Scheibenfeder	Woodruff key
24	506 890 0	1	14x1 DIN 471	Sicherungsring	Circlip
25	562 949 0	2	27,7x17,3x1,45	Tellerfeder	Cup spring
26	506 386 0	1	17x1 DIN 471	Sicherungsring	Circlip
27	507 837 0	1	37x47x0,3 DIN 988	Passscheibe	Adjusting washer
28	1	M8x40 ISO 4762	Zyl-Schraube	Socket head cap screw
29	1	RNA 4901 DIN 617	Nadellager	Needle roller bearing
30	2	AS 16x28x7 NB	Wellendichtring	Shaft seal
31	1	115x3 NB 70	Runddichtring	Round sealing ring
35	02 220 20 02 0	1		Anschlusskasten	Terminal box

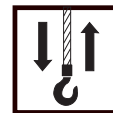

A1 ex
SF 17 ... 113

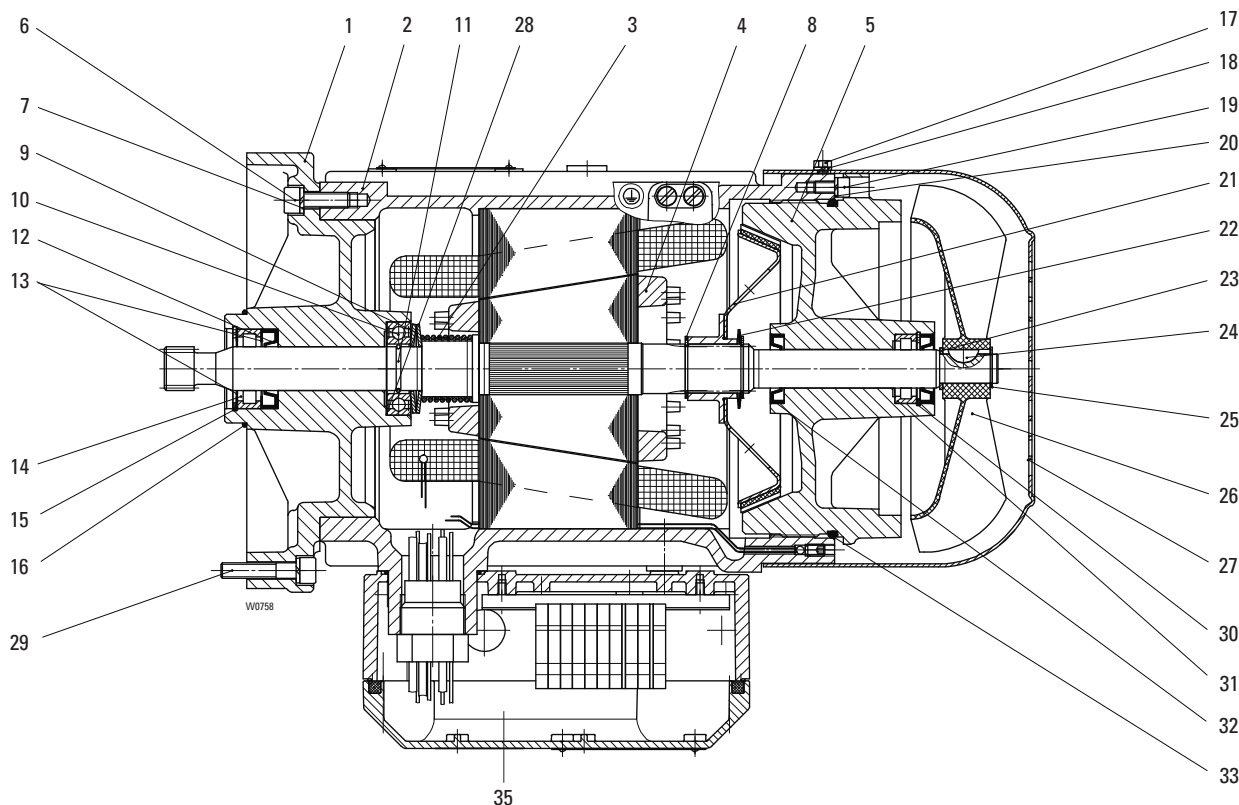

Pos	Teil-Nummer Part-Number	Stück Piece	Beschreibung Description	Benennung Designation
	41 330 42 11 0	1	2/8A1 IIB	Motor
	41 330 43 11 0	1	2/8A1 IIC	Motor
1	41 331 27 03 0	1	IIB	Motorflansch
	41 331 28 03 0	1	IIC	Motor flange
2	41 330 73 14 9	1	2/8A1	Stator
3	38 331 01 94 0	1		Druckfeder
4	41 330 26 13 0	1		Rotor
5	41 330 06 37 0	1	IIB	Motordeckel
	41 330 05 37 0	1	IIC	Motor cover
	41 330 07 37 0	1	IIC	
6	500 234 0	4	M8x25	Zyl-Schraube
7	506 459 0	4	8	Federring
8	506 097 0	2	25x1,2	Sicherungsring
9	41 331 00 14 0	2	45x22,4x3,05x1,75	Tellerfeder
10	560 951 0	1	6005-2RS	Rillenkugellager
12	561 854 0	1	A22x40x8	Wellendichtring
13	506 805 0	2	28x40x0,5	Passscheibe
14	560 844 0	1	RNU 203 E	Zyl-Rollenlager
15	506 262 0	1	40x1,75	Sicherungsring
16	515 946 0	1	55x2	Runddichtring
17	500 419 0	4	M5x8	Skt-Schraube
18	506 900 0	4	5	Federring
19	500 230 0	4	M6x12	Zyl-Schraube
20	506 335 0	4	6	Federring
21	41 330 20 18 0	1		Bremsscheibe
22	562 939 0	2		Tellerfeder

1) Bitte Betriebsspannung und Frequenz angeben.
2) hartverchromt

1) Please state operating voltage and frequency.
2) Hard chrome plated



Originalteile
Original parts
SH 4 ex

A1 ex
SF 17 ... 113

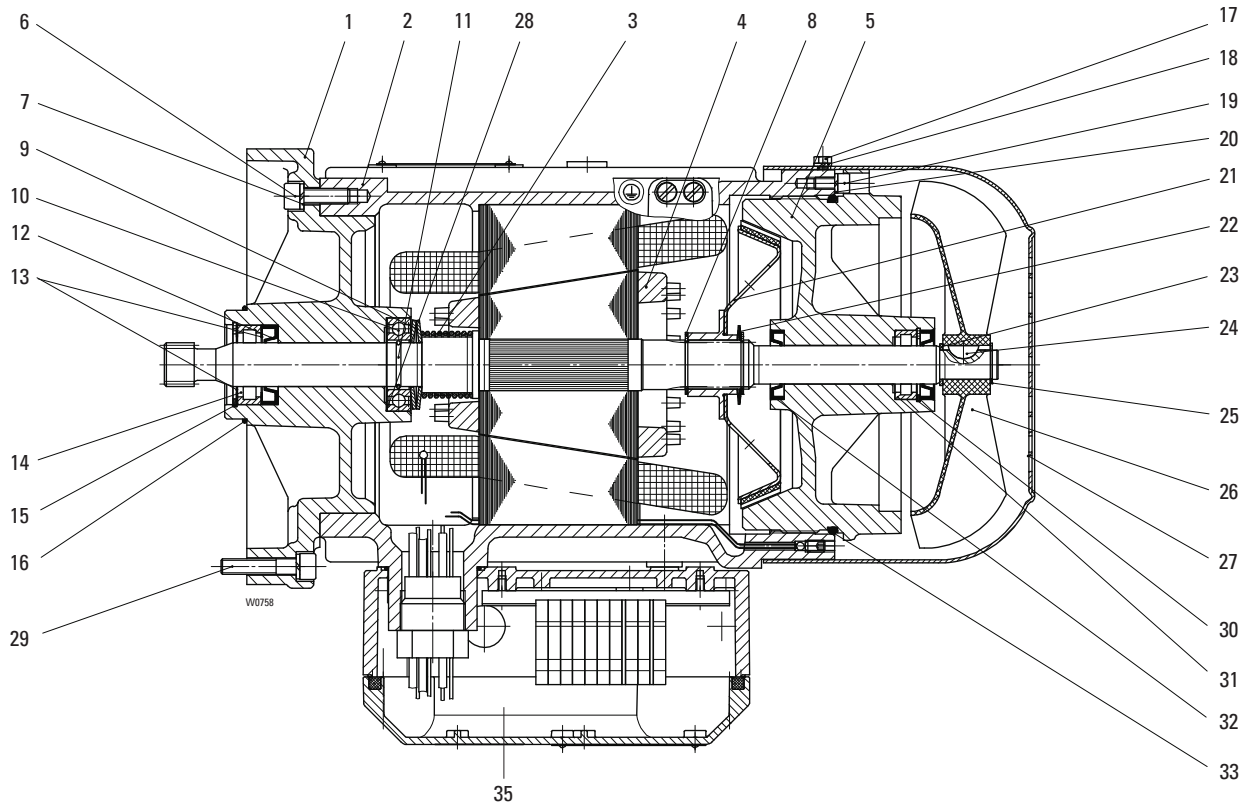

Pos	Teil-Nummer Part-Number	Stück Piece	Beschreibung Description	Benennung Designation
23	506 844 0	1	S15x21x1,5	Stützscheibe
24	537 936 0	1	5x6,5	Scheibenfeder
25	506 093 0	1		Sicherungsring
26	576 030 0	1	V100 R/15	Lüfterrad
27	41 331 21 40 0	1		Lüfterhaube
28	507 837 0	1	37x47x0,3	Passscheibe
29	500 146 0	4	M8x40	Zyl-Schraube
30	1	35x1,5	Sicherungsring
31	1	RNU 202 E	Zyl-Rollenlager
32	2	A19x35x7	Wellendichtring
33	515 980 0	1	160x4	Runddichtring
35	02 220 20 02 0	1		Anschlusskasten

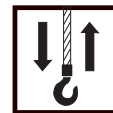

A1 ex
SF 17 ... 103

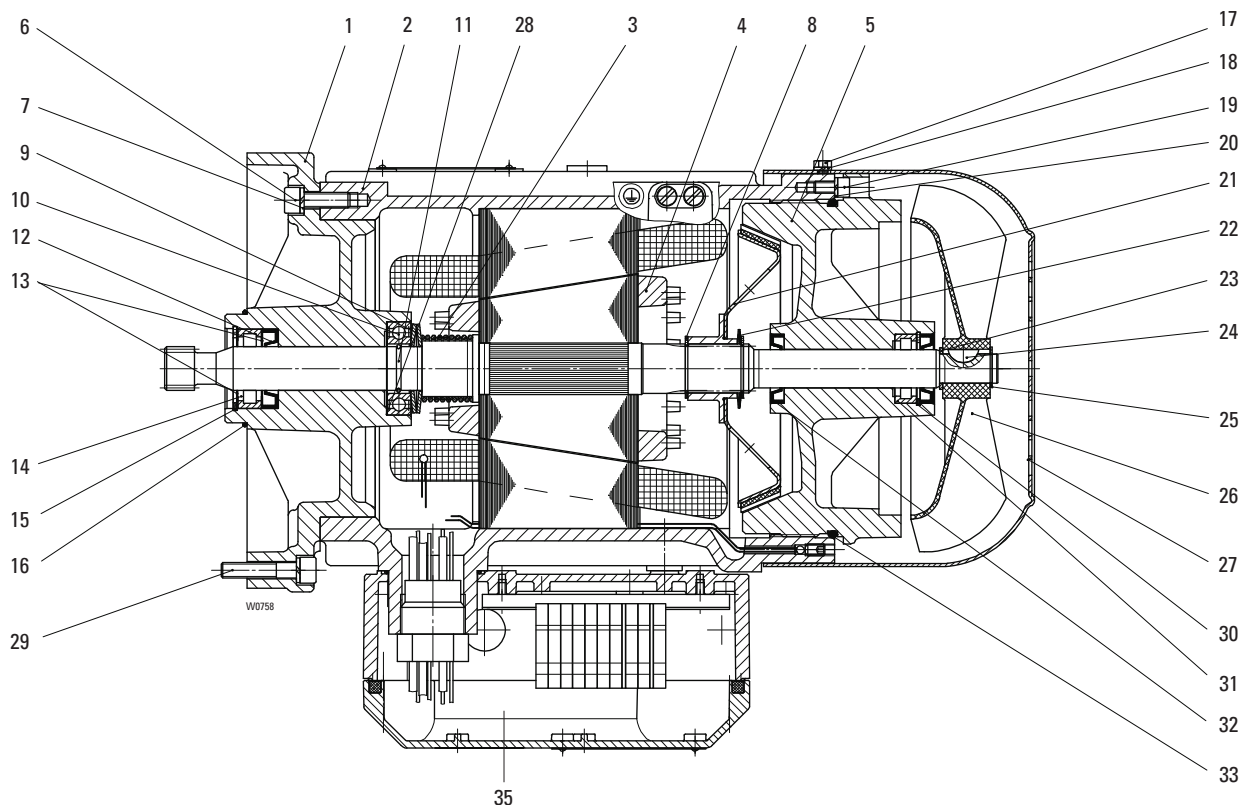

Pos	Teil-Nummer Part-Number	Stück Piece	Beschreibung Description	Benennung	Designation
	41 330 40 11 0	1	2/8A1 IIB	Motor	Motor
	41 330 41 11 0	1	2/8A1 IIC		
1	41 331 27 03 0	1	IIB	Motorflansch	Motor flange
	41 331 28 03 0	1	IIC		
2	41 330 74 14 9	1	2/8A1	Stator	Stator
3	38 331 01 94 0	1		Druckfeder	Pressure spring
4	41 330 26 13 0	1		Rotor	Rotor
5	41 330 06 37 0	1	IIB	Motordeckel	Motor cover
	41 330 05 37 0	1	IIC		
	41 330 07 37 0	1	IIC		
6	500 234 0	4	M8x25	Zyl-Schraube	Socket head cap
7	506 459 0	4	8	Federring	Locking ring
8	506 097 0	2	25x1,2	Sicherungsring	Circlip
9	41 331 00 14 0	2	45x22,4x3,05x1,75	Tellerfeder	Cup spring
10	560 951 0	1	6005-2RS	Rillenkugellager	Grooved ball bearing
12	561 854 0	1	A22x40x8	Wellendichtring	Shaft seal
13	506 805 0	2	28x40x0,5	Passscheibe	Adjusting washer
14	560 844 0	1	RNU 203 E	Zyl-Rollenlager	Roller bearing
15	506 262 0	1	40x1,75	Sicherungsring	Circlip
16	515 946 0	1	55x2	Runddichtring	Round sealing ring
17	500 419 0	4	M5x8	Skt-Schraube	Hexagon head cap screw
18	506 900 0	4	5	Federring	Spring washer
19	500 230 0	4	M6x12	Zyl-Schraube	Socket head cap screw
20	506 335 0	4	6	Federring	Spring washer
21	41 330 20 18 0	1		Bremsscheibe	brake disc
22	562 939 0	2		Tellerfeder	Cup spring

1) Bitte Betriebsspannung und Frequenz angeben.
2) hartverchromt

1) Please state operating voltage and frequency.
2) Hard chrome plated



Originalteile
Original parts
SH 4 ex

A1 ex
SF 17 ... 103

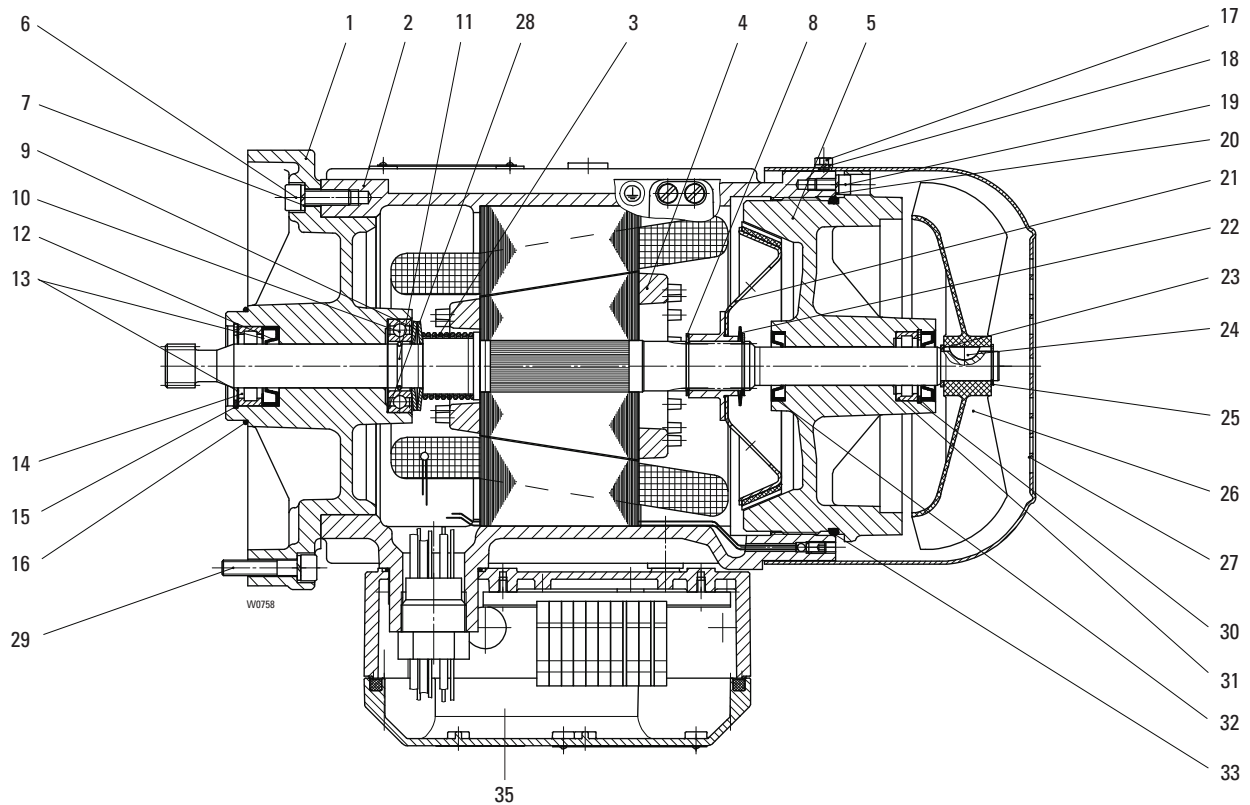

Pos	Teil-Nummer Part-Number	Stück Piece	Beschreibung Description	Benennung Designation
23	506 844 0	1	S15x21x1,5	Stützscheibe
24	537 936 0	1	5x6,5	Scheibenfeder
25	506 093 0	1		Sicherungsring
26	576 030 0	1	V100 R/15	Lüfterrad
27	41 331 21 40 0	1		Lüfterhaube
28	507 837 0	1	37x47x0,3	Passscheibe
29	500 146 0	4	M8x40	Zyl-Schraube
30	1	35x1,5	Sicherungsring
31	1	RNU 202 E	Zyl-Rollenlager
32	2	A19x35x7	Wellendichtring
33	515 980 0	1	160x4	Runddichtring
35	02 220 20 02 0	1		Anschlusskasten

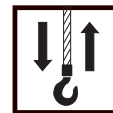

SF 17 2..

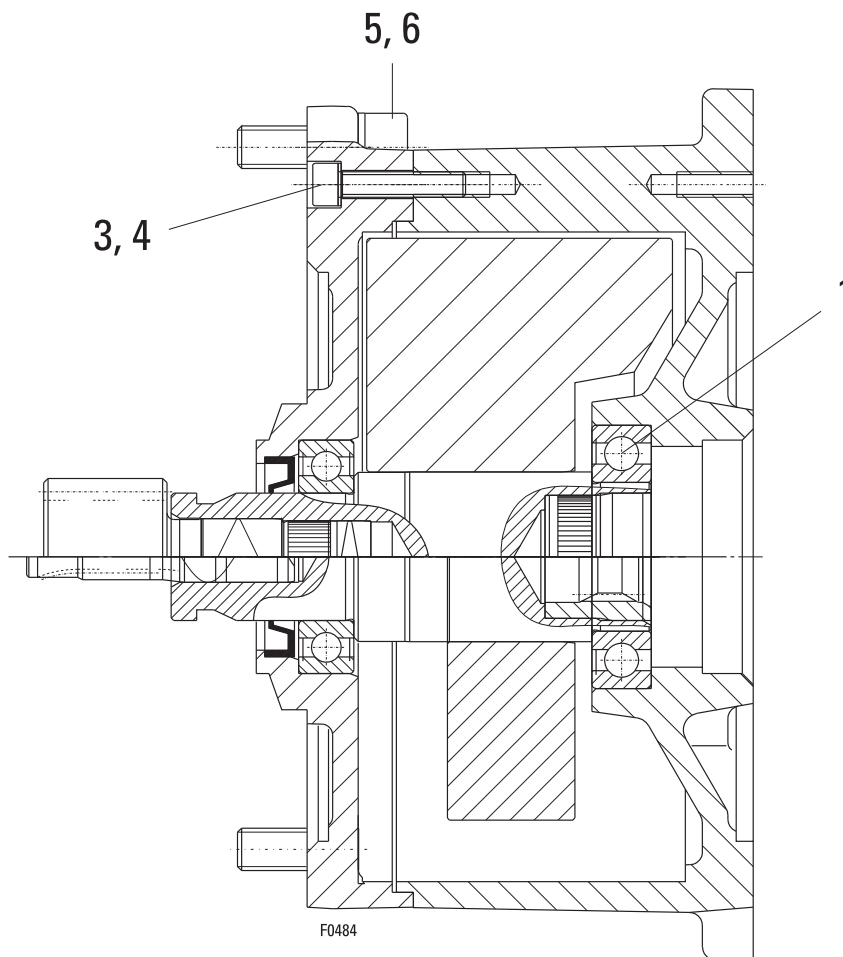

Pos	Teil-Nummer Part-Number	Stück Piece	Beschreibung Description	Benennung	Designation		
	21 270 10 32 0	1	SF 17 219 503	Schwungradkupplung	Flywheel coupling		
	21 270 11 32 0	1	SF 17 217 503				
	21 270 12 32 0	1	SF 17 215 503				
	21 270 13 32 0	1	SF 17 213 503				
	21 270 14 32 0	1	SF 17 211 503				
	21 270 15 32 0	1	SF 17 209 503				
	21 270 16 32 0	1	SF 17 207 503				
	21 270 18 32 0	1	SF 17 217 113				
	21 270 19 32 0	1	SF 17 215 113				
	21 270 20 32 0	1	SF 17 213 113				
	21 270 21 32 0	1	SF 17 211 113				
	21 270 22 32 0	1	SF 17 209 113				
	21 270 23 32 0	1	SF 17 207 113				
	21 270 28 32 0	1	SF 17 211 103				
	21 270 29 32 0	1	SF 17 209 103				
	21 270 30 32 0	1	SF 17 207 103				
1	560 989 0	1	6007-2Z DIN 625			Rillenkugellager	Grooved ball bearing
3	500 976 0	8	M6x30 ISO 4762-8.8			Zyl-Schraube	Socket head cap screw
4	506 838 0	8	S6			Sicherungsscheibe	Lock washer
5	500 236 0	4	M10x30 DIN 912-8.8			Zyl-Schraube	Socket head cap screw
6	506 128 0	4	VS10	Sicherungsscheibe	Lock washer		



Originalteile
Original parts
SF 4 ex

SF 17 2..

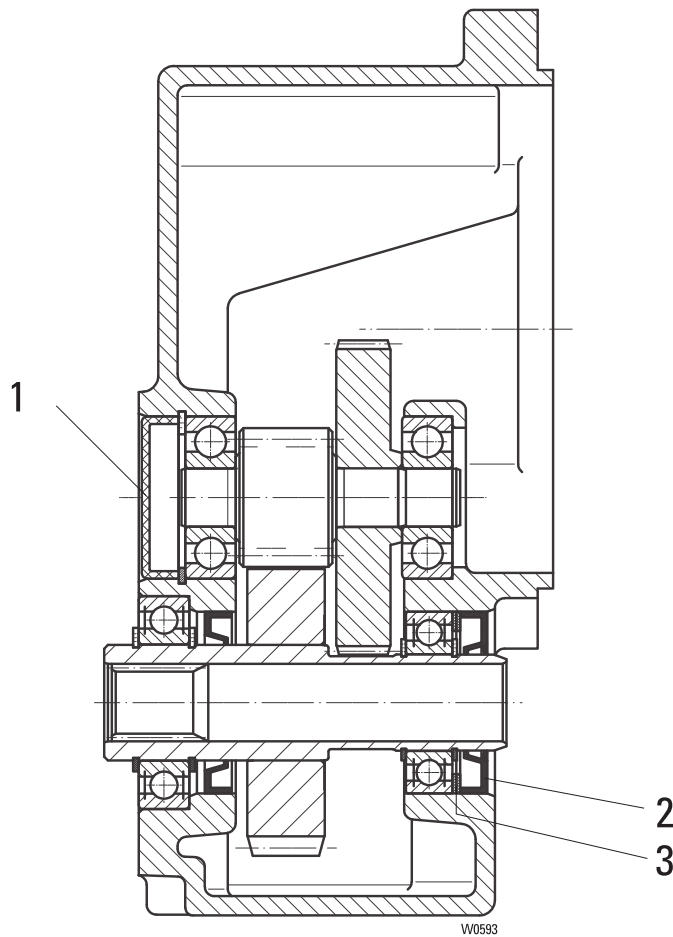

Pos	Teil-Nummer Part-Number	Stück Piece	Beschreibung Description	Benennung	Designation
	21 270 04 30 0	1	SF17 219	Getriebe	Gear
	21 270 05 30 0	1	SF17 217		
	21 270 06 30 0	1	SF17 215		
	21 270 07 30 0	1	SF17 213		
	21 270 08 30 0	1	SF17 211		
	21 270 09 30 0	1	SF17 209		
	21 270 10 30 0	1	SF17 207		
1	518 036 0	1	42x9,5		
2	561 120 0	1	25x47x7	Wellendichtring	Shaft seal
3	507 876 0	2	37x47x1	Passscheibe	Adjusting washer

Getriebe nur komplett lieferbar.
Ohne Getriebeöl: Erforderliche Menge siehe Betriebsanleitung

Gear only available as complete unit.
Without gear oil: amount required see operating instruction

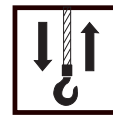

SF 17

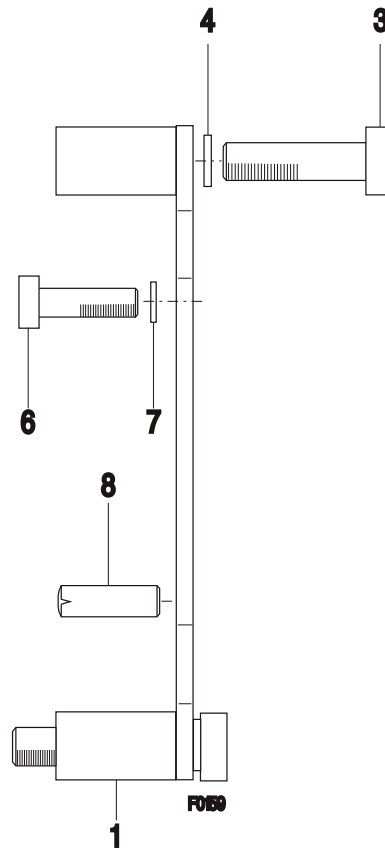

Pos	Teil-Nummer Part-Number	Stück Piece	Beschreibung Description	Benennung	Designation
1	21 270 01 22 0	1	SF1 (Pos.3-8)	Drehmomentstütze	Torque support
3	500 980 0	4	M8x45 DIN 912-8.8	Zyl-Schraube	Socket head cap screw
4	506 839 0	4	S8	Sicherungsscheibe	Locking disc
6	500 144 0	4	M8x16 DIN 912-8.8	Zyl-Schraube	Socket head screw
7	506 839 0	4	S8	Sicherungsscheibe	Locking disc
8	504 960 0	2	8m6x24 DIN 7	Zyl-Stift	Pin



Originalteile
Original parts
SH 4 ex



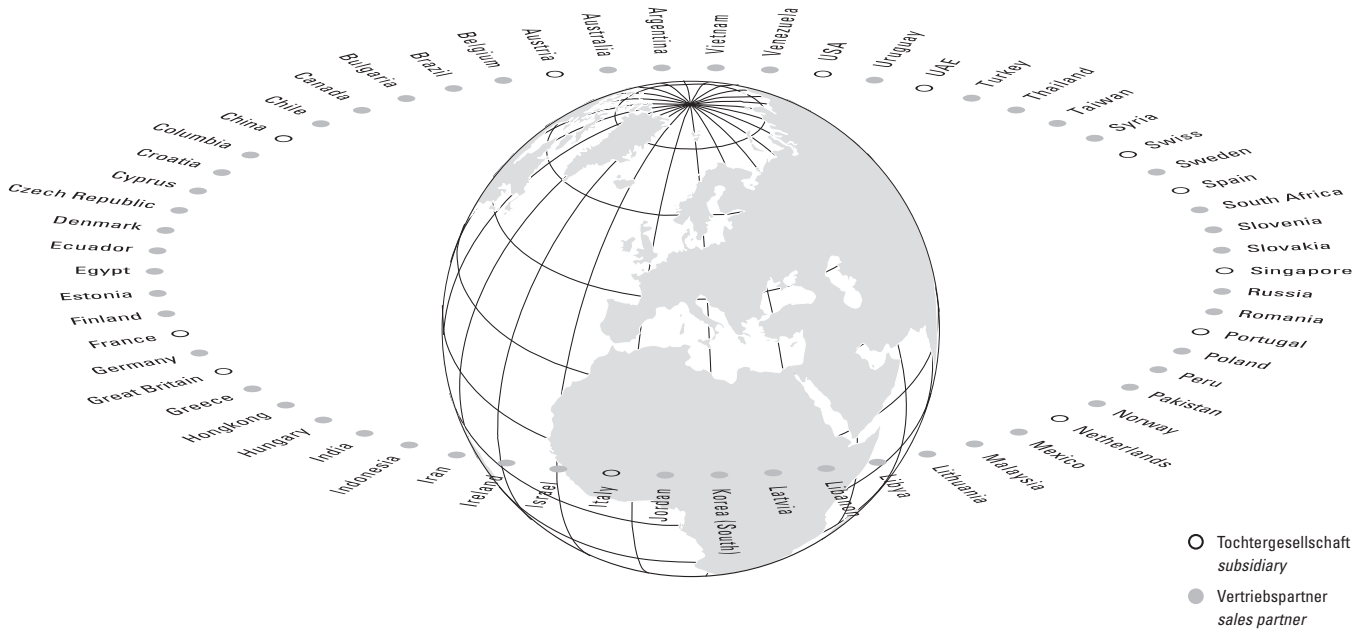

Europe		T	F	E
Austria	Steyregg	+43 732 641111-0	+43 732 641111-33	office@stahlcranes.at
France	Paris	+33 1 39985060	+33 1 34111818	info@stahlcranes.fr
Great Britain	Birmingham	+44 121 7676414	+44 121 7676490	info@stahlcranes.co.uk
Italy	S. Colombano	+39 0185 358391	+39 0185 358219	info@stahlcranes.it
Netherlands	EL Haarlem	+31 23 51252-20	+31 23 51252-23	info@stahlcranes.nl
Portugal	Lissabon	+351 21 44471-61	+351 21 44471-69	ferrometal@ferrometal.pt
Spain	Madrid	+34 91 484-0865	+34 91 490-5143	info@stahlcranes.es
Switzerland	Däniken	+41 62 82513-80	+41 62 82513-81	info@stahlcranes.ch

America/Asia		T	F	E
China	Shanghai	+86 21 6257 2211	+86 21 6254 1907	victor.low@stahlcranes.cn
India	Chennai	+91 44 4352-3955	+91 44 4352-3957	anand@stahlcranes.in
Singapore	Singapore	+65 6271 2220	+65 6377 1555	sales@stahlcranes.sg
U.A.E.	Dubai	+971 4 805-3700	+971 4 805-3701	info@stahlcranes.ae
USA	Charleston, SC	+1 843 767-1951	+1 843 767-4366	sales@stahlcranes.us

Россия ООО "КранШталь" 109451, г.Москва, ул. Верхние поля, д.28
тел./факс: +7 495 2253788 +7 495 9214517 info@stahlcranes.ru

→ www.kranstahl.ru
→ www.tali-market.ru

→ www.servis-kran.ru
→ www.stahlcranes.ru

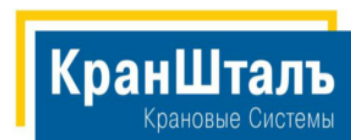

Partner of

