

# КранСталь



SH 3



---

## Explosiongeschützte Seilzüge \_

↘ DE

Originalteileliste

---

## Explosion-Protected Wire Rope Hoists \_

↘ EN

Original parts list

⊕ II 2 G (ATEX) - Zone 1

⊕ II 2 D (ATEX) - Zone 21

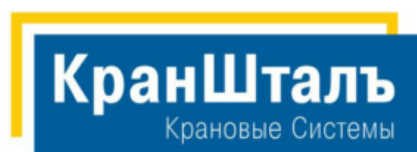

<http://kranstahl.ru>  
[info@kranstahl.ru](mailto:info@kranstahl.ru)

Partner of



+7 (495) 225-37-88



**Notizen**  
**Notice**

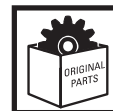
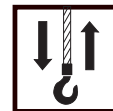

Hubmotor .....	4	Hoist motor .....	4
Zwischengetriebe .....	6	Intermediate gear .....	6
Getriebe .....	7	Gear .....	7
Seiltrommel .....	8	Rope drum .....	8
Seilaufhängung .....	9	Rope suspension .....	9
Hakengeschirr .....	11	Bottom hook block .....	11
Hakentraverse .....	13	Hook traverse .....	13
Hakenflasche .....	14	Bottom hook block .....	14
Gerätekasten .....	17	Control panel .....	17
Steuerung .....	18	Control .....	18
Steuergerät .....	18	Control pendant .....	18
Fahrwerke .....	19	Trolleys .....	19
Fahrantriebe .....	21	Travel drives .....	21
Drehmomentstütze .....	29	Torque support .....	29

Austausch und Reparaturen nur von geschultem Personal ausführen lassen.

Die Angaben in der Spalte "Benennung" dienen nur internen Vorgängen.

Replacement and repairs may only be carried out by trained personnel.

The information in the column "Designation" is only for internal use.

**Bitte immer die Fabrik-Nr. des Hebezeuges angeben.**

**Please always state hoist serial number.**



**Originalteile**  
**Original parts**  
**SH3 ex**

**A2 ex**

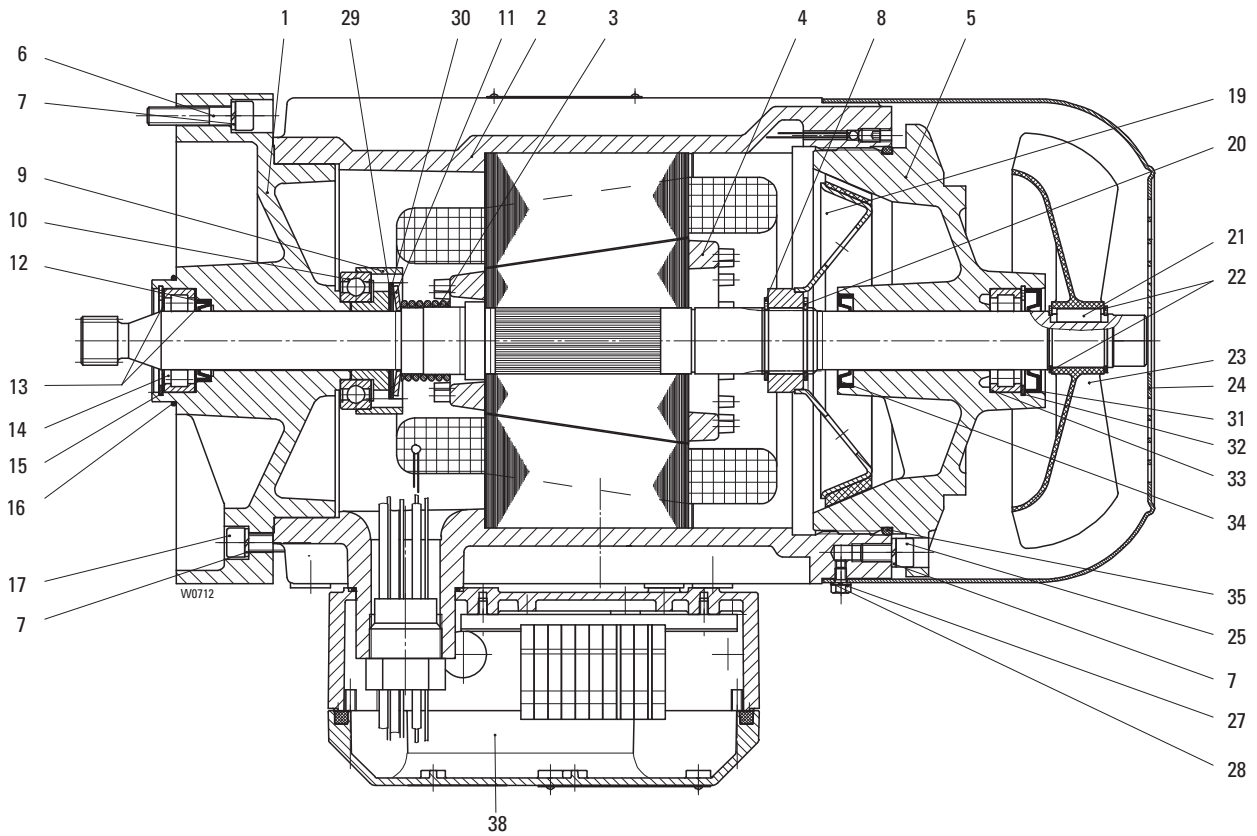

Pos	Teil-Nummer Part-Number	Stück Piece	Beschreibung Description	Benennung Designation
	42 330 50 10 0	1	2/12A2 IIB	Motor
	42 330 51 10 0	1	2/12A2 IIC	Motor
1	42 331 22 03 0	1	IIB	Motorflansch
	42 331 23 03 0	1	IIC	Motorflansch
2	42 330 76 14 9	1	2/12A2	Stator
3	42 331 00 94 0	1		Druckfeder
4	42 330 20 13 0	1		Rotor
	42 330 22 13 0	1		Rotor
5	42 330 06 37 0	1	IIB	Motordeckel
	42 330 04 37 0	1	IIC	Motordeckel
	42 330 03 37 0	1	IIC	Motordeckel
6	500 146 0	4	M8x40	Zyl-Schraube
7	506 459 0	12	8	Federring
8	506 098 0	1	30x1,5	Sicherungsring
9	42 331 20 51 0	1		Abstandsring
10	560 067 0	1	6007-2RS-C3	Rillenkugellager
11	42 331 00 14 0	1	500x27,3x3,4x2	Tellerfeder
12	561 822 0	1	A27x37x7	Wellendichtring
13	42 331 00 52 0	2		Scheibe
14	560 845 0	1	RNU 204 E	Zyl-Rollenlager
15	506 106 0	1	47x1,75	Sicherungsring
16	515 946 0	1	55x2	Runddichtring
17	500 234 0	4	M8x25	Zyl-Schraube
19	42 330 20 18 0	1		Bremsscheibe
20	506 569 0	1	A30x1,5L	Sicherungsring
21	537 958 0	1	B6x6x20	Passfeder



Pos	Teil-Nummer Part-Number	Stück Piece	Beschreibung Description	Benennung	Designation
22	506 428 0	2	24x1,2	Sicherungsring	Circlip
23	576 019 0	1	V100 R/24	Lüfterrad	Fan wheel
24	42 331 20 40 0	1		Lüfterhaube	Fan cover
25	500 144 0	4	M8x16	Zyl-Schraube	Socket head cap screw
27	500 419 0	4	M5x8	Skt-Schraube	Hexagon head cap screw
28	506 042 0	4	A5	Sicherungsring	Circlip
29	507 817 0	3	42x52x0,3	Passscheibe	Ajusting washer
30	507 816 0	1	42x52x1	Passscheibe	Ajusting washer
31	.. .. .	1		Wellendichtring	Shaft seal
32	... ..	1	47x1,75	Sicherungsring	Circlip
33	... ..	1	RNU 204 E	Zyl-Rollenlager	Roller bearing
34	... ..	1	A27x42x7	Wellendichtring	Shaft seal
35	515 980 0	1	160x4	Runddichtring	Round sealing ring
38	02 220 20 02 0	1		Anschlusskasten	Terminal box

\*1 Bitte angeben: Abtriebswelle Linksschräg; rechtsschräg; geradverzahnt

- 1) Bitte Betriebsspannung und Frequenz angeben.
- 2) Ausführung linksschräg
- 3) Ausführung rechtsschräg
- 4) hartverchromt

\*1 Please state: with output shaft left-handed; right-handed; spur-toothed

- 1) Please state operating voltage and frequency.
- 2) Left-hand design
- 3) Righthand design
- 4) Hard chrome plated



**Originalteile**  
**Original parts**  
**SH3 ex**

**Zwischengetriebe / Intermediate gear**

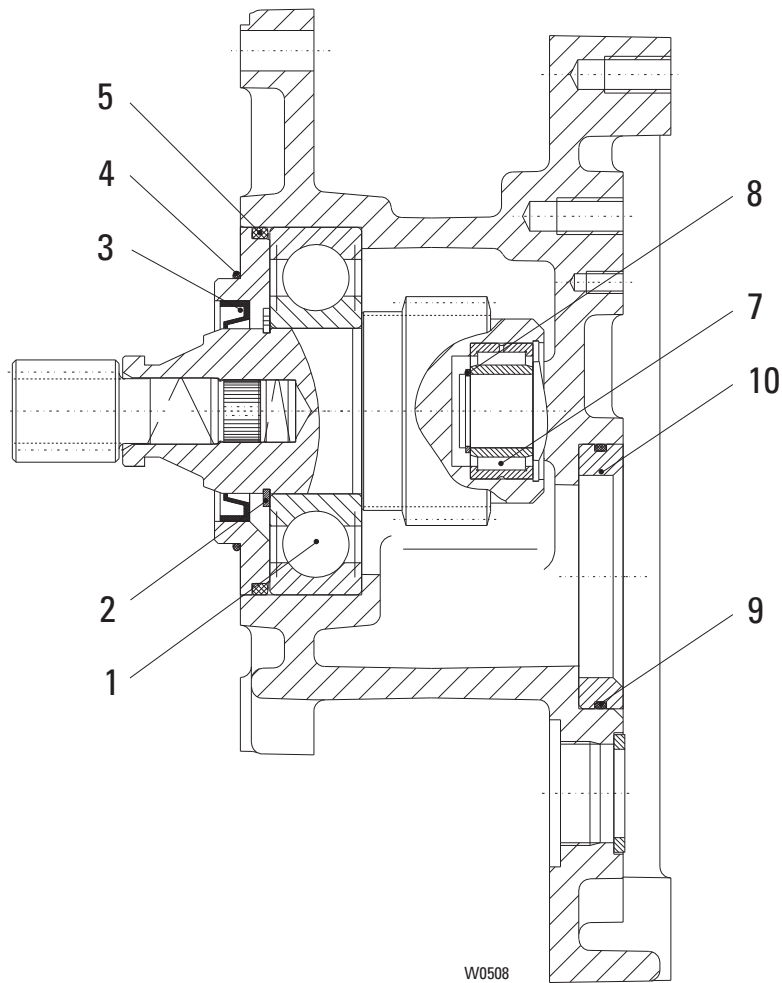

Pos	Teil-Nummer Part-Number	Stück Piece	Beschreibung Description	Benennung	Designation
	24 270 30 30 0	1	SH 30..-7	Zwischengetriebe	Intermediate gear
		1	SH 30..-9		
	24 270 31 30 0	1	SH 30..-11		
		1	SH 30..-14		
	24 270 32 30 0	1	SH 30..-18		
		1	SH 30..-24		
1	560 829 0	1	6309-27	Rillenkugellager	Grooved ball bearing
2	506 101 0	1	45x1,75	Sicherungsring	Locking ring
3	561 026 0	1	45x60x8 NB	Wellendichtring	Shaft seal
4	515 953 0	1	70x2	Runddichtring	Round sealing ring
5	515 970 0	1	90x4	Runddichtring	Round sealing ring
7	560 995 0	1	NA 4904	Nadellager	needle roller bearing
8	507 122 0	1	SW 20	Sprengring	Circlip
9	515 986 0	1	67x2,5	Runddichtring	Round sealing ring
10	24 273 00 49 0	1		Zentrierring	Eccentric ring

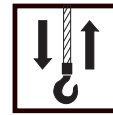

**Getriebe/Gear**

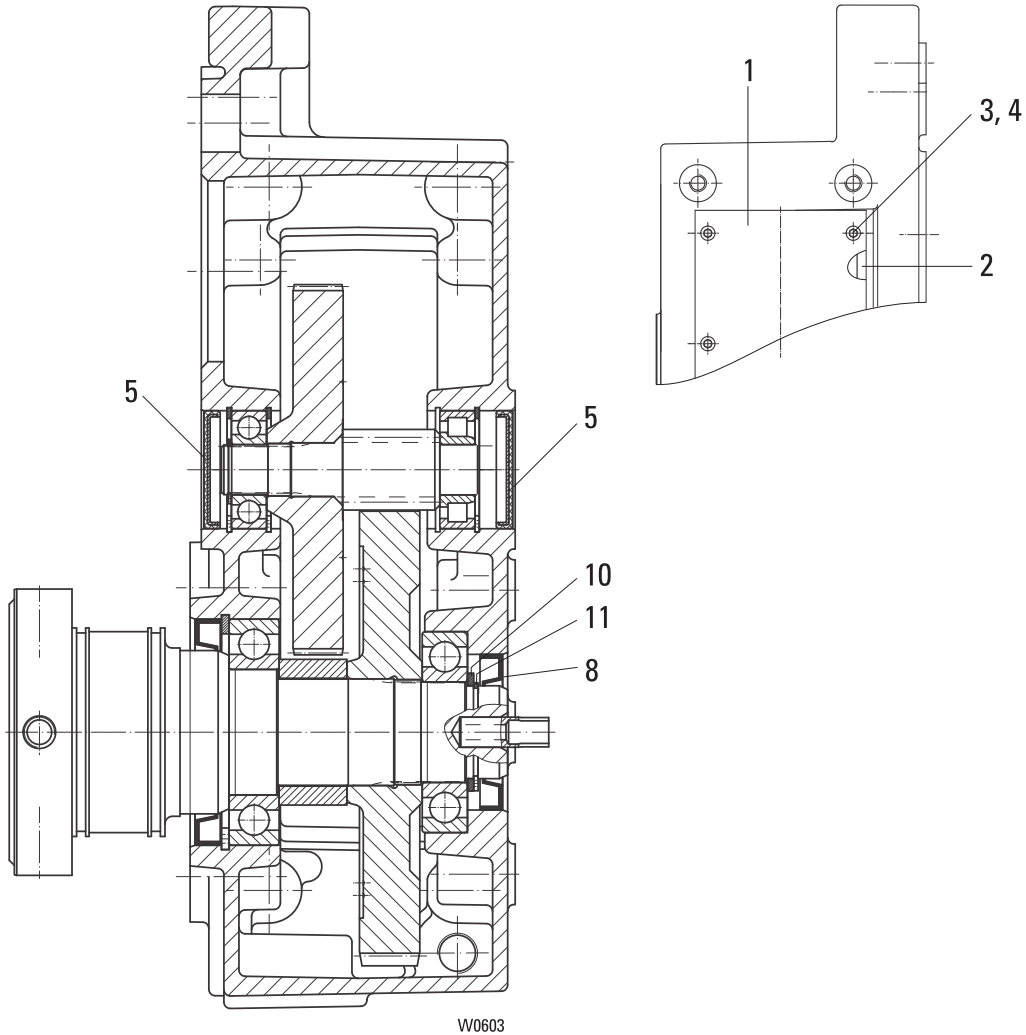

Pos	Teil-Nummer Part-Number	Stück Piece	Beschreibung Description	Benennung Designation	Designation	
	23 270 03 30 0	1	SH 30...-7	1)	Getriebe	Gear
	23 270 04 30 0	1	SH 30...-9	1)		
	23 270 05 30 0	1	SH 30...-11	1)		
	23 270 06 30 0	1	SH 30...-14	1)		
	23 270 07 30 0	1	SH 30...-18	1)		
	23 270 08 30 0	1	SH 30...-24	1)		
1	23 273 00 96 0	1				
2	23 273 00 95 0	1			Dichtung	Seal
3	50 810 0	8	M6x16	DIN 6912-8.8	Zyl-Schraube	Socket head cap screw
4	506 838 0	8	S16		Sicherungsscheibe	Locking disc
5	518 041 0	2	47x6,5		Verschlusskappe	End cap
8	561 027 0	1	37x62x9	DIN 3760 NB	Wellendichtring	Shaft seal
10	506 095 0	1	20x1,2	DIN 471	Sicherungsring	Locking ring
11	506 088 0	1	S37x47x2,5	DIN 988	Stützscheibe	Supporting ring

1) Getriebe bis auf gekennzeichnete Teile nur komplett lieferbar.  
Ohne Getriebeöl: Erforderliche Menge siehe Betriebsanleitung

1) Gear only available as complete unit except the signed parts  
Without gear oil: amount required see operating instruction.



**Originalteile**  
**Original parts**  
**SH3 ex**

**Seiltrommel/rope drum**

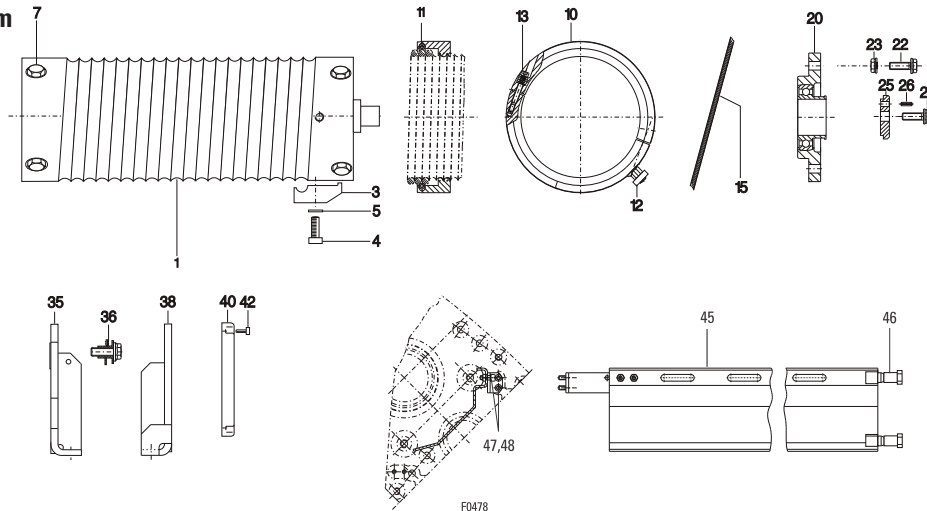

Pos	Teil-Nummer Part-Number	Stück Piece	Beschreibung Description		Benennung	Designation
1	03 434 00 04 0	1	L2	1) /1 D6,5-7	Seiltrommel	Rope drum
	03 434 01 04 0	1	L3	1) /1 D6,5-7		
1	03 434 04 04 0	1	L2	1) /2- D5,5	Seiltrommel	Rope drum
	03 434 05 04 0	1	L3	1) /2- D5,5		
3	04 430 01 46 0	3	D6,5-7	/1 (Pos.4+5)	Klemmplatte	Clamping plate
4	500 290 0	3	M10x20	DIN 6912-8.8	Zyl-Schraube	Socket head cap screw
5	506 840 0	3	S 10		Sicherungsscheibe	Locking disc
3	03 430 00 46 0	6	D5,5	/2- (Pos.4+5)	Klemmplatte	Clamping plate
4	500 810 0	6	M6x16	DIN 6912-8.8	Zyl-Schraube	Socket head cap screw
5	506 838 0	6	S 6		Sicherungsscheibe	Locking disc
7	500 015 0	8	M12x35	DIN 7968-8.8	Skt-Paßschraube	Screw
10	03 430 02 43 0	1	D6,5-7	/1 2) (Pos.11-13)	Seilführungsring	Rope guide
	03 430 00 43 0	1	D5,5	/2- 2) (Pos.11-13)		
	03 430 01 43 0	1	D5,5	/2- 3) (Pos.11-13)		
11	03 434 00 94 0	1			Zugfeder	Tension spring
12	04 430 01 47 0	1			Führungsteil	Guide part
13	21 334 00 90 0	2			Schraube	Screw
15				4)	Drahtseil	Wire rope
20	560 027 0	1	INA PME 25		Flanschlager	Flange bearing
22	501 119 0	4	M8x25		Sicherungsschraube	Locking screw
23	507 112 0	4	M8		Sicherungsmutter	Locking nut
25	03 432 01 52 0	1			Haltescheibe	Holding disc
26	504 990 0	1	5x10	DIN 1481	Spannstift	Clamping sleeve
27	501 119 0	1	M8x25		Sicherungsschraube	Locking screw
35	03 432 00 01 0	1		5)	Tragblech Getriebeseite	Support plate gear side
	03 432 02 01 0	1		6)		
36	03 430 00 26 0	2			Bundbuchse	Bushing
38	03 432 01 01 0	1		5)	Tragblech Lagerseite	Support plate bearing side
	03 432 03 01 0	1		6)		
40	03 432 00 40 0	1			Abschlußhaube	End cover
42	505 034 0	4	M6x20	DIN 7500	Schraube	Screw
45	03 430 00 22 0	1	L2	(Pos.46-48)	Fettwanne	Grease box
	03 430 01 22 0	1	L3	(Pos.46-48)		
46	04 432 00 90 0	2			Schraube	Screw
47	500 233 0	4	M6x16	ISO 4762	Zyl.-Schraube	Socket head cap screw
48	506 838 0	4	S6		Sicherungsscheibe	Lock washer

- 1) Pos.20 immer mitbestellen.
- 2) Seilführung Linksgewinde
- 3) Seilführung Rechtsgewinde
- 4) Siehe Datenblatt
- 5) Seilzug stehend stationär
- 6) Seilzug hängend stationär

- 1) Always included item 20 in order
- 2) Rope guide left thread
- 3) Rope guide right thread
- 4) See data sheet
- 5) Stationary wire rope hoist, upright
- 6) Stationary wire rope hoist, suspended



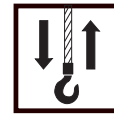

Seilabhängung/rope suspension

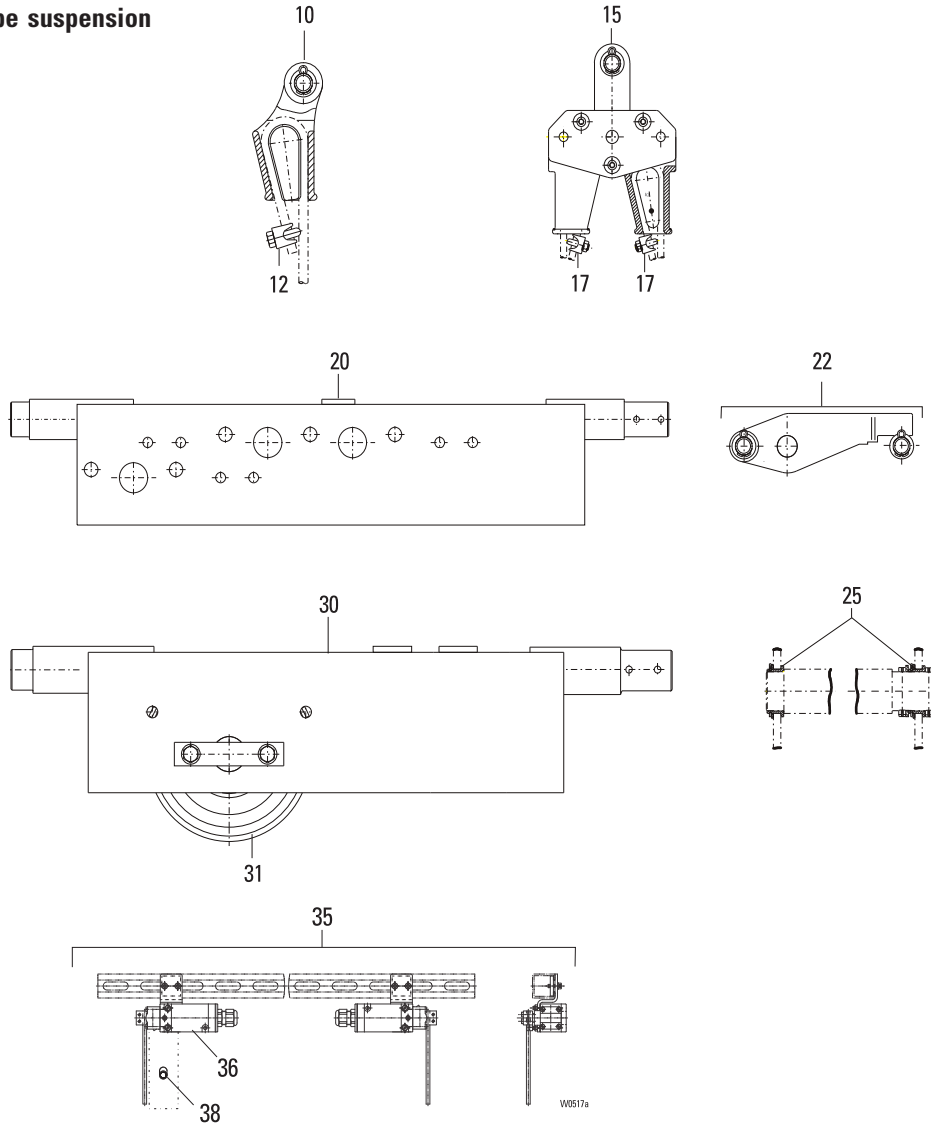

Pos	Teil-Nummer Part-Number	Stück Piece	Beschreibung Description	Benennung Designation
10	03 430 02 48 0	1	(Pos.12)	Keilendklemme Clamp
12	517 005 0	1	Gr.8	Drahtseilklemme Wire rope clamp
15	03 430 00 23 0	1	(Pos.17)	Wippe Rocking bar
17	517 993 0	2	Gr.6	Drahtseilklemme Wire rope clamp
20	03 430 00 28 0	1	L2 1)	Aufhängertraverse Suspension traverse
	03 430 01 28 0	1	L3 1)	
22	03 430 07 28 0		x)	Aufhängung Suspension
25	03 430 01 26 0		x)	Bundbuchse Bushing
30	03 430 00 27 0	1	L2 1) (Pos.31)	Umlenkung Deflection cross bar
	03 430 01 27 0	1	L3 1) (Pos.31)	
31	01 430 00 53 0	1	D125 mm	Seilrolle Rope pulley
35	04 430 20 85 0	1	1) (Pos.36)	Endschalteranbau Limit switch attachment
36	04 430 23 85 0	2		Ex-Positionsschalter Limit switch
38	503 020 0	1	M8x1x80-14Hvz DIN427	Schaftschraube Screw



**Originalteile**  
**Original parts**  
**SH3 ex**

**Seilauflhängung/rope suspension**

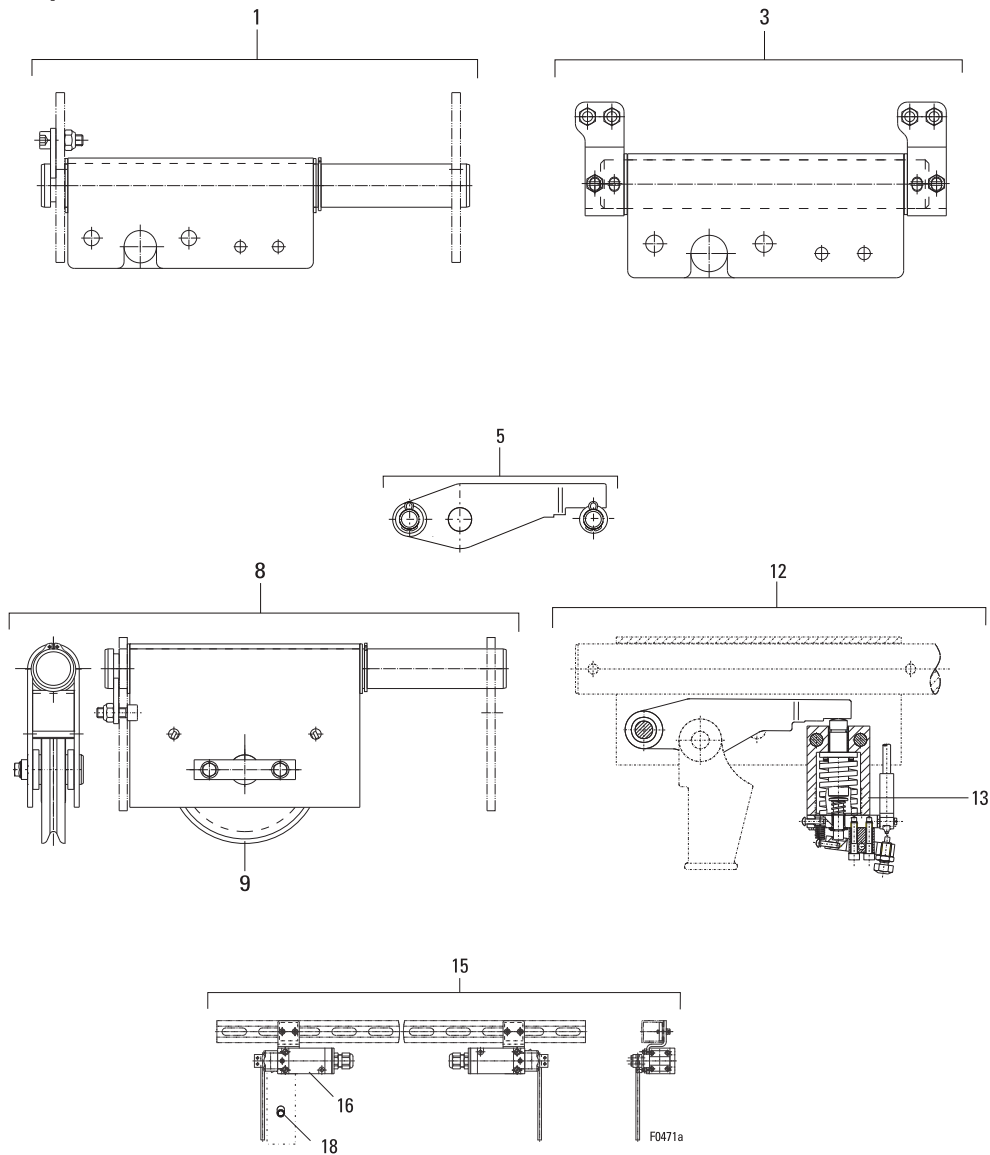

Pos	Teil-Nummer Part-Number	Stück Piece	Beschreibung Description		Benennung	Designation
1	03 430 08 28 0	1	2/1	1)	Aufhängung	Suspension
3	03 430 09 28 0	1	4/1	1)	Aufhängung	Suspension
5	03 430 07 28 0	1			Aufhängung	Suspension
8	03 430 04 27 0	1		1) (Pos.9)	Umlenkung	Deflection cross bar
9	01 430 00 53 0	1	D125		Seilrolle	Rope pulley
12	03 430 00 94 0	1	400 daN	(Pos.13)	Lastsensor	Load sensor
	03 430 01 94 0	1	500 daN			
	03 430 02 94 0	1	630 daN			
	03 430 03 94 0	1	800 daN			
13	03 430 00 84 0	1	400 daN		Meseinheit	Measuring unit
	03 430 01 84 0	1	500 daN			
	03 430 02 84 0	1	630 daN			
	03 430 03 84 0	1	800 daN			
15	04 430 20 85 0	1		1) (Pos.16)	Endschalteranbau	Limit switch attachment
16	04 430 23 85 0	2			Ex-Positionsschalter	Limit switch
18	503 020 0	1	M8x1x80-14Hvz	DIN 427	Schaftschraube	Screw

1) KE-S4, OE-S04

1) KE-S4, OE-S04

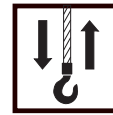

H70-1

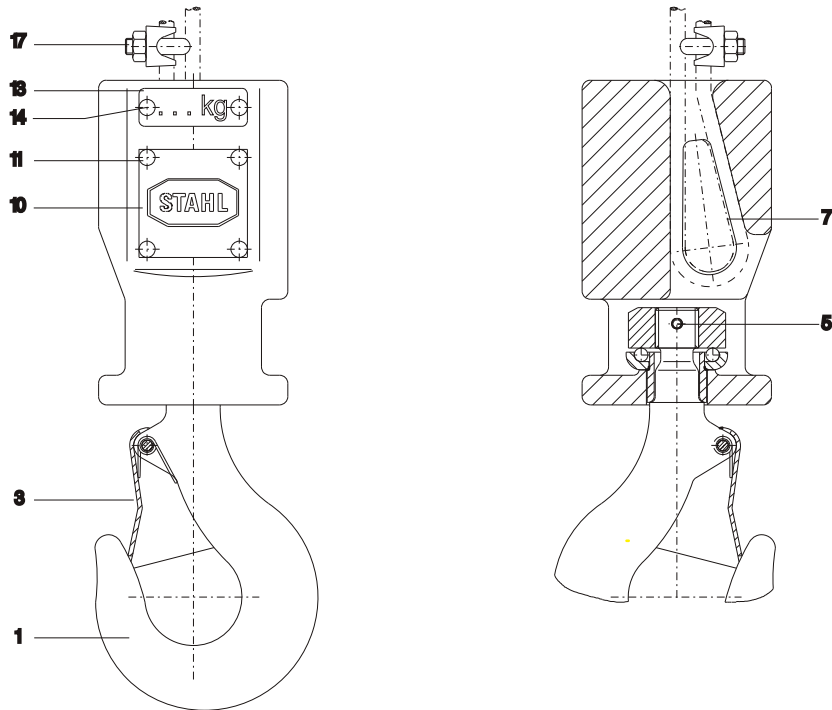

F0200

Bitte immer die Fabrik-Nr. des Hebezeuges angeben.

Please always state hoist serial number.



Originalteile  
Original parts  
SH3 ex

H110-1

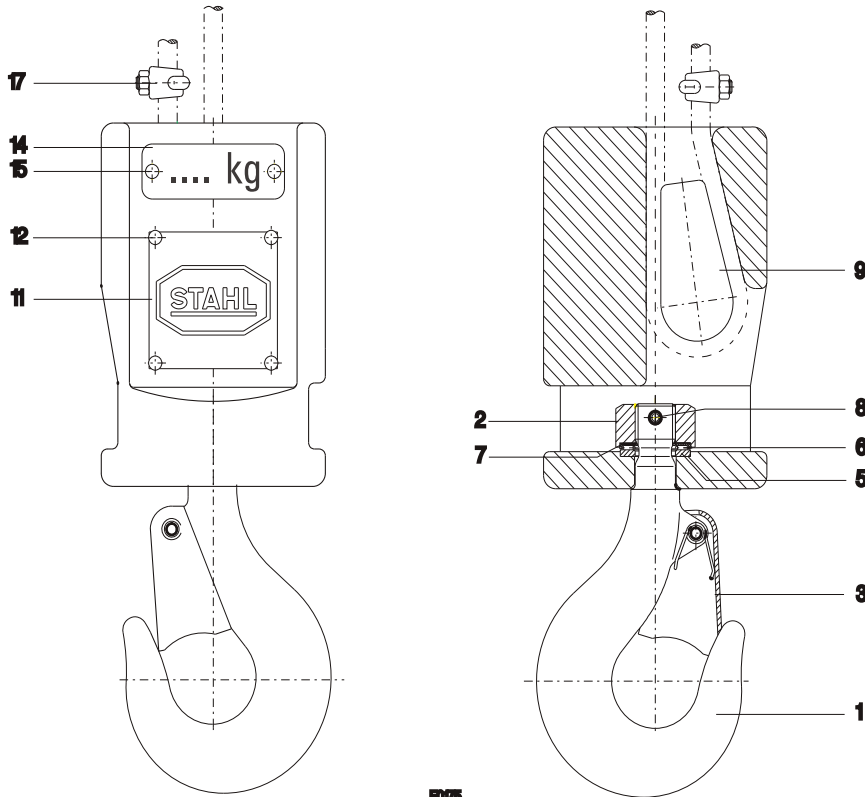

F076

Bitte immer die Fabrik-Nr. des Hebezeuges angeben.

Please always state hoist serial number.



T100-2

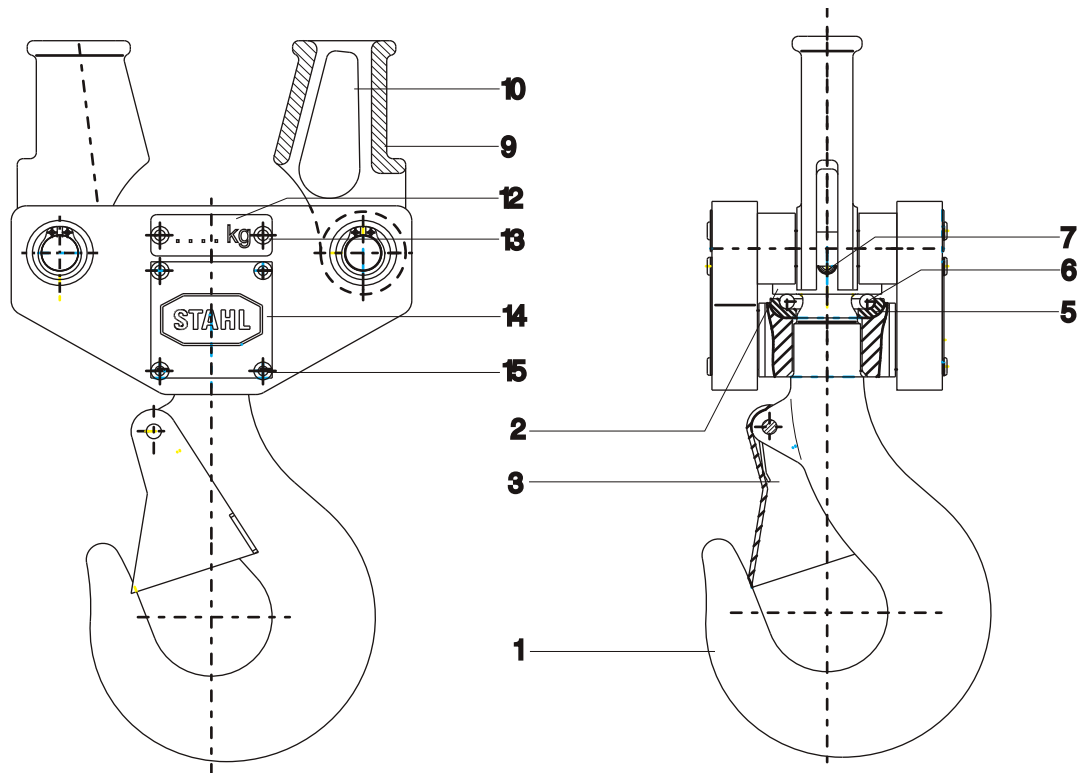

F0228

Bitte immer die Fabrik-Nr. des Hebezeuges angeben.

Please always state hoist serial number.



**Originalteile**  
**Original parts**  
**SH3 ex**

H125-2

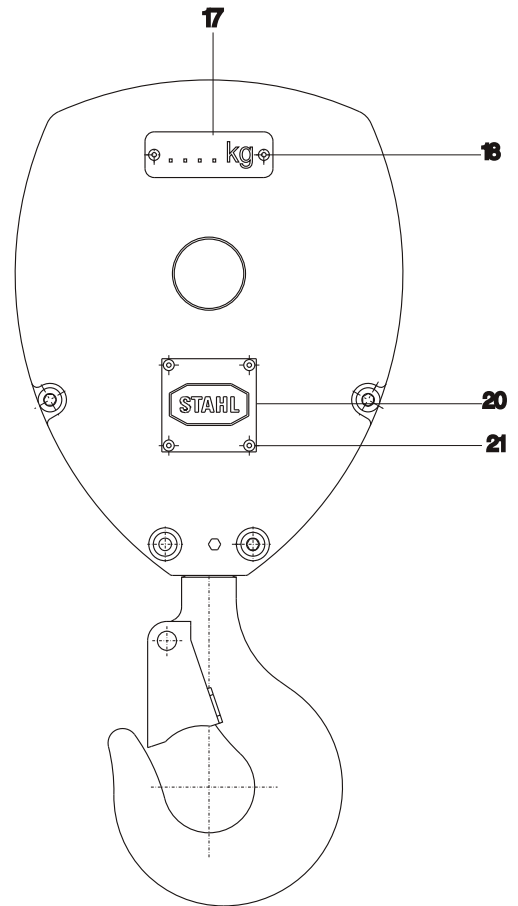
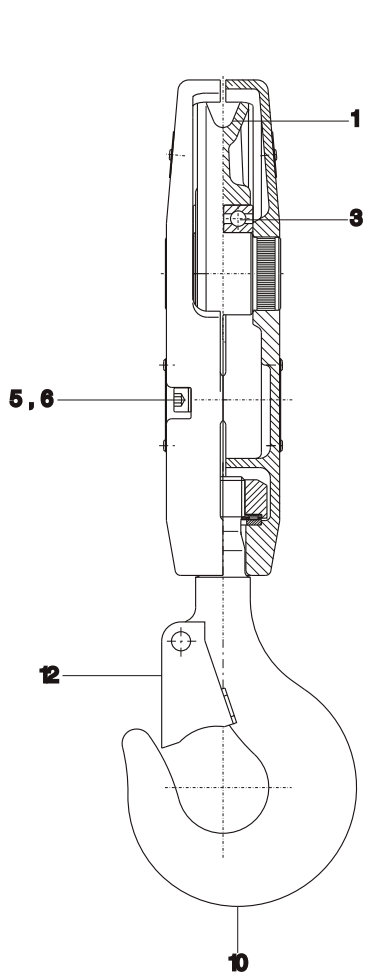

F0139a

**Bitte immer die Fabrik-Nr. des Hebezeuges angeben.**

**Please always state hoist serial number.**

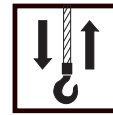

H100-4  
H101-4

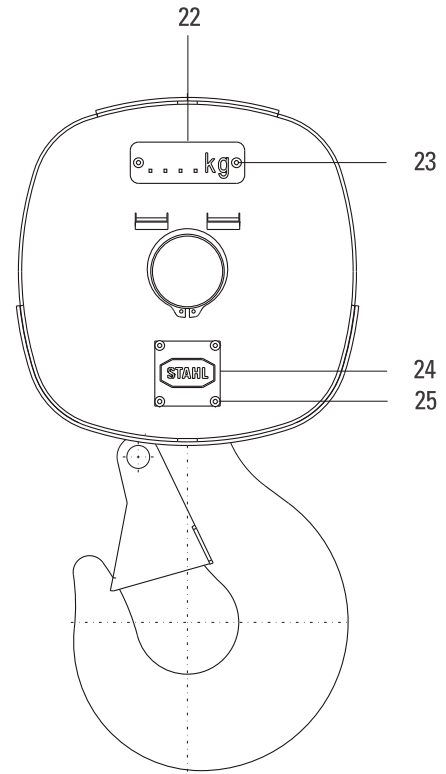
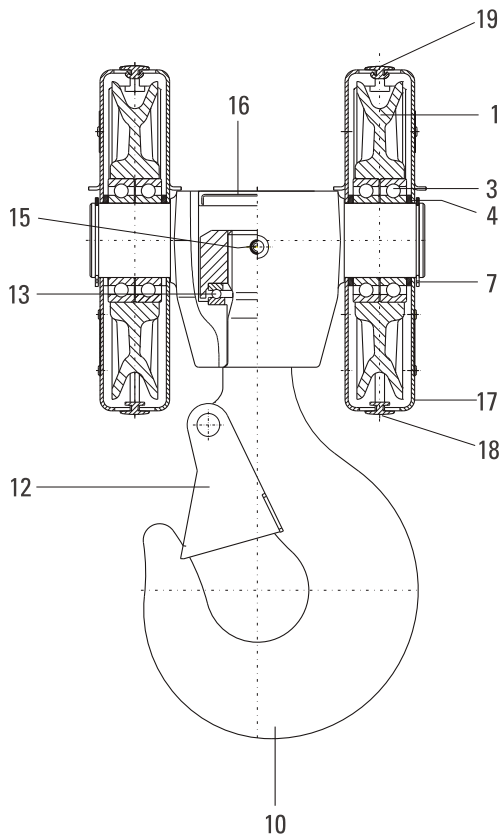

W0535

Bitte immer die Fabrik-Nr. des Hebezeuges angeben.

Please always state hoist serial number.



**Originalteile**  
**Original parts**  
**SH3 ex**

H125-4

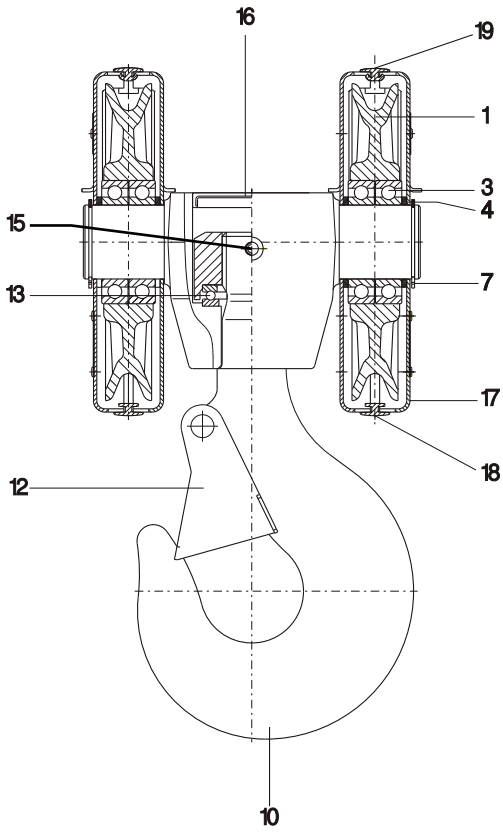

FO257a

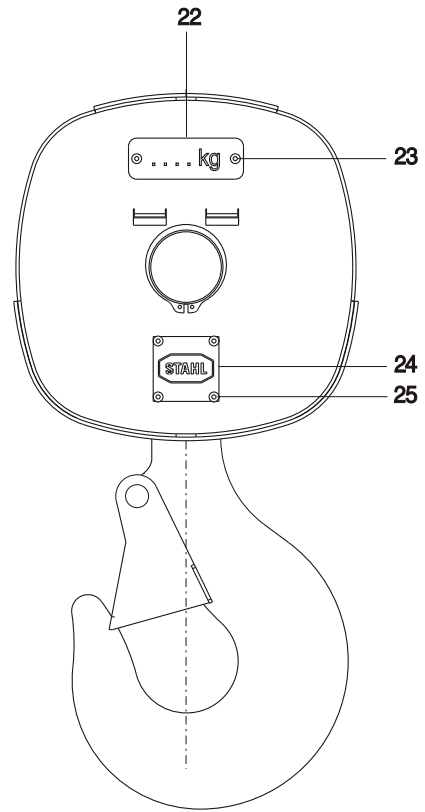

**Bitte immer die Fabrik-Nr. des Hebezeuges angeben.**

**Please always state hoist serial number.**



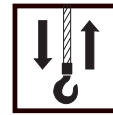

**K-A 3. ex**

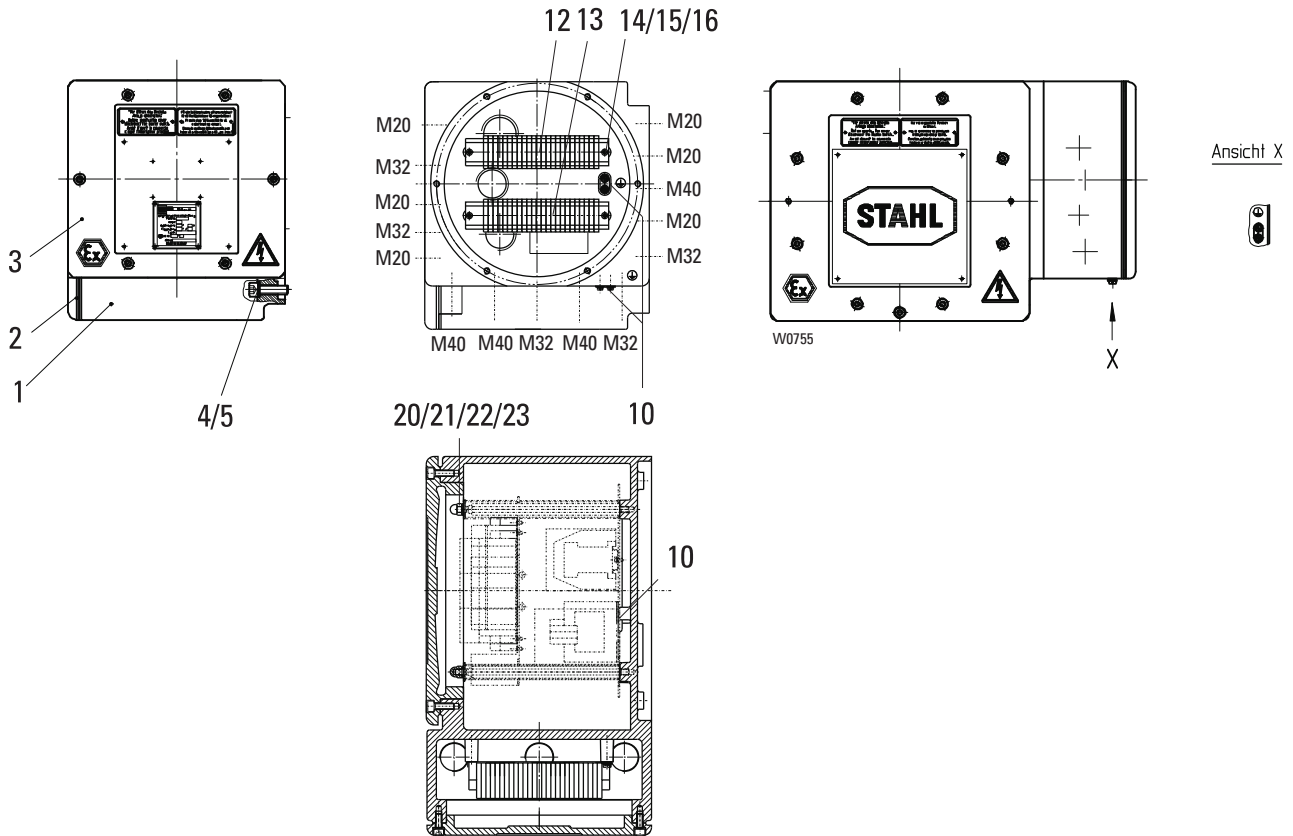

Pos	Teil-Nummer Part-Number	Stück Piece	Beschreibung Description	Benennung	Designation
1	04 439 01 20 0	1	IIB	Gerätekasten	Terminal box
1	04 439 02 20 0	1	IIC		
2	04 430 71 97 0	1	d280	Kastendeckel	Box cover
3	04 430 80 97 0	1	e240	Kastendeckel	Box cover
4	500 184 0	3	M12x40	Zyl.-Schraube	Socket head cap screw
5	506 841 0	3	S12	Sicherungsscheibe	Lock washer
10	46 330 70 81 0	3		Erdungsklemme	Earth clamp
12	03 430 41 89 0	1		Klemmleiste	Terminal strip
13	03 430 39 89 0	1		Klemmleiste	Terminal strip
14	502 051 0	4	M4x8	Zyl.-Schraube	Socket head cap screw
15	506 374 0	4	4	Federring	Spring washer
16	506 062 0	4	4,3	Scheibe	Disc
20	506 859 0	2	8,4	Scheibe	Disc
21	506 839 0	2	S8	Sicherungsscheibe	Lock washer
22	506 924 0	2	M8	Hutmutter	Cap nut
23	44 329 20 92 0	2		Führungsbolzen	Guiding bolt



**Originalteile**  
**Original parts**  
**SH3 ex**

**Standard -Steuerung / standard control**  
**400V / 50Hz**

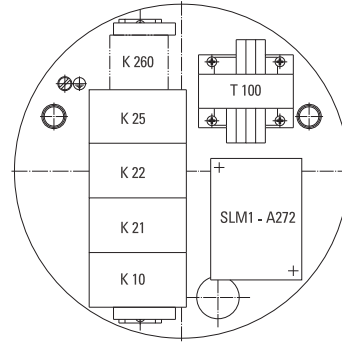
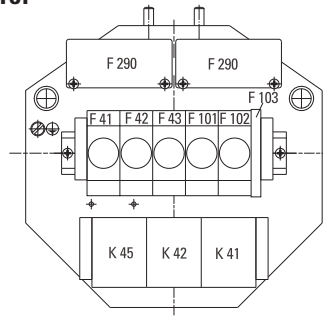

W0521

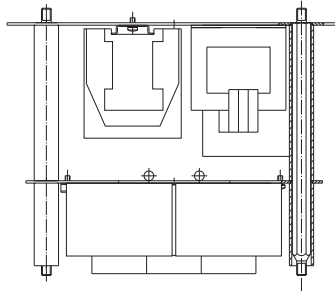

**Geräteliste / parts list**

**Motor 12/2 A2 ex**

**Siehe auftragsbezogene Geräteliste in der Seilzug- Dokumentation**  
**See parts list in individual wire rope hoist documentation.**

**Standardsteuergerät / Standard control switch**

Typ Type	Teil-Nummer Part-Number
SWH 5102-061 ex	15 390 80 20 9
SWH 5106-061 ex	15 390 79 20 9
SWH 5202-062 ex	15 390 78 20 9
SWH 5206-062 ex	15 390 77 20 9

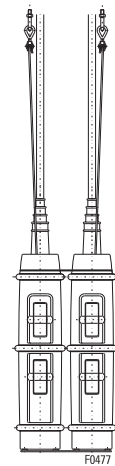

Sondersteuergeräte: Bitte Typ angeben.

Special control switches: Please state type.

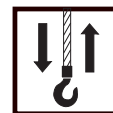

**KE-S3**

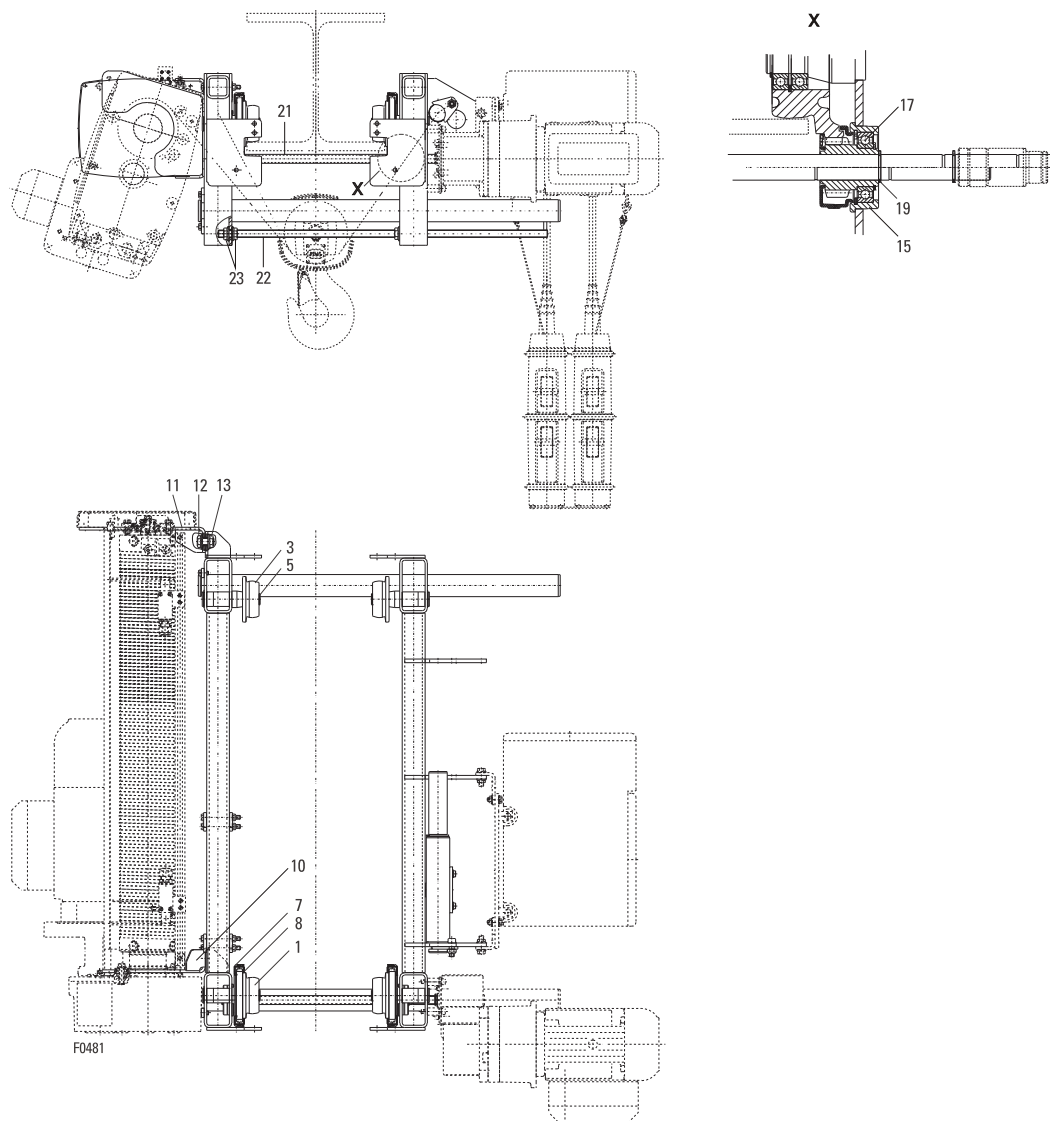

Pos	Teil-Nummer Part-Number	Stück Piece	Beschreibung Description	Benennung Designation	Designation	
1	03 250 05 40 0	2	A80	L3/5	Laufrolle	Wheel
3	03 250 04 41 0	2	B80	L3/5	Laufrolle	Wheel
5	506 097 0	4	25x1,2	DIN 471	Sicherungsring	Locking ring
7	03 254 00 40 0	2			Laufrollenabdeckung	Wheel cover
8	03 254 01 40 0	2			Laufrollenabdeckung	Wheel cover
10	03 432 05 01 0	1			Tragblech	Support plate
11	03 432 04 01 0	1			Tragblech	Support plate
12	501 123 0	4	M16x30-10		Sicherungsschraube	Locking screw
13	507 841 0	4	M16		Sicherungsmutter	Locking nut
15	21 270 01 39 0	2		(Pos.17)	Flanschlager kompl.	Flange bearing complete
17	560 936 0	2	6006-2Z	DIN 625	Rillenkugellager	Grooved ball bearing
19	507 098 0	2	20x1,75	DIN 471	Sicherungsring	Locking ring
21	21 273 11 60 0	1		1)	Durchtriebswelle	Drive shaft
	21 273 08 60 0	1		1)		
	21 273 12 60 0	1		1)		
	21 273 13 60 0	1		1)		
22	025 002 9	2	M16x720	DIN 976-8.8	Gewindebolzen	Threaded bolt
23	507 841 0	8	M16		Sicherungsmutter	Locking nut

1) Flanschbreite

1) Flange width



**Originalteile**  
**Original parts**  
**SH3 ex**

OE-S04

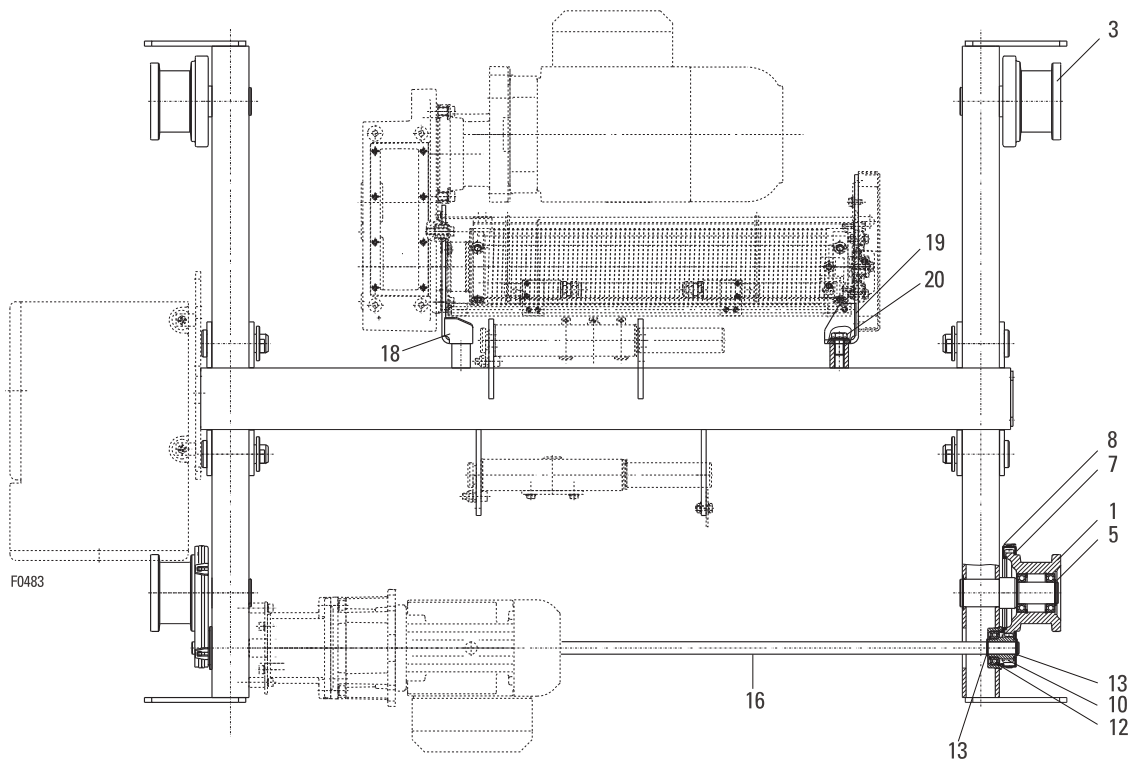

Pos	Teil-Nummer Part-Number	Stück Piece	Beschreibung Description		Benennung	Designation
1	24 250 00 40 0	2	A100	1) 40 mm	Laufрад	Wheel
	24 250 01 40 0	2		1) 50 mm		
3	24 250 00 41 0	2	B100	1) 40 mm	Laufрад	Wheel
	24 250 01 41 0	2		1) 50 mm		
5	506 099 0	4	35x1,5	DIN 471	Sicherungsring	Locking ring
7	04 254 03 40 0	2			Laufrollenabdeckung	Wheel cover
8	04 254 04 40 0	2			Laufrollenabdeckung	Wheel cover
10	21 270 01 39 0	2		(Pos.12)	Flanschlager kompl.	Flange bearing complete
12	560 936 0	2	6006-2Z	DIN 625	Rillenkugellager	Grooved ball bearing
13	507 098 0	2	20x1,75	DIN 471	Sicherungsring	Locking ring
16	21 273 05 60 0	1		2) 1250 mm	Durchtriebswelle	Drive shaft
	21 273 03 60 0	1		2) 1400 mm		
	21 273 04 60 0	1		2) 2240 mm		
18	03 432 05 01 0	1			Tragblech Getriebeseite	Support plate gear side
19	03 432 04 01 0	1			Tragblech Lagerseite	Support plate bearing side
20	501 107 0	4	M16x25-10		Sicherungs-schraube	Locking screw

1) Schienenbreite  
2) Spurweite

1) Rail width  
2) Track gauge

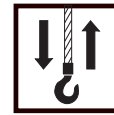

**A05 ex**  
**SF 17 ... 50.3**

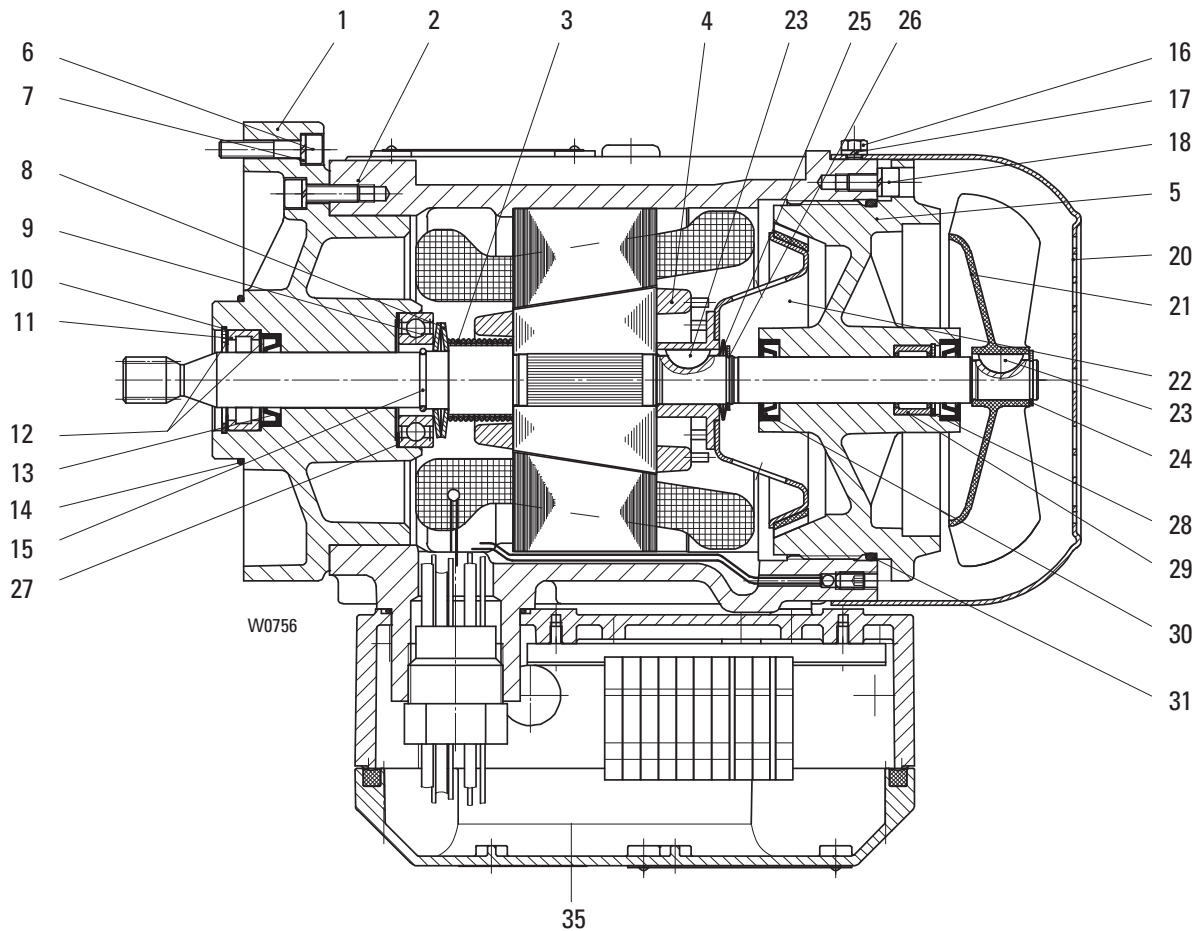

Pos	Teil-Nummer Part-Number	Stück Piece	Beschreibung Description	Benennung Designation
	35 330 56 11 0	1	2/8A05 IIB	1) (Pos.1-31)
	35 330 57 11 0	1	2/8A05 IIC	1) (Pos.1-31)
1	35 331 23 03 0	1	IIB	Motorflansch
	35 331 24 03 0	1	IIC	Motorflansch
2	35 330 77 14 9	1	1)	Stator
3	33 331 20 94 0	1		Druckfeder
4	35 330 28 13 0	1		Rotor
5	35 330 05 37 0	1	IIB	Motordeckel
	35 330 04 37 0	1	IIC	Motordeckel
	35 330 06 37 0	1	2)	Motordeckel
6	500 976 0	8	M6X30	Zyl.-Schraube
7	506 335 0	8	6	Federring
8	562 901 0	2	40x20,4x2,65x1,5	Tellerfeder
9	560 951 0	1	6005-2RS	Rillenkugellager
10	506 261 0	1	35x1,5	Sicherungsring
11	506 843 0	1	RNU202E	Zyl.-Rollenlager
12	506 889 0	2	25x35x0,3	Passscheibe
13	561 893 0	1	A19x32x7	Wellendichtring
14	515 946 0	1	55x2	Runddichtring
15	507 836 0	1	A20	Spreng ring
16	500 419 0	4	M5x8	Skt-Schraube
17	506 900 0	4	5	Federring
18	500 230 0	4	M6x12	Zyl.-Schraube
20	35 331 22 40 0	1		Lüfterhaube
21	576 033 0	1	V71 R/14	Lüfterrad

1) Bitte Betriebsspannung und Frequenz angeben.  
2) hartverchromt

1) Please state operating voltage and frequency.  
2) Hard chrome plated



**Originalteile**  
**Original parts**  
**SH3 ex**

**A05 ex**  
**SF 17 ... 50.3**

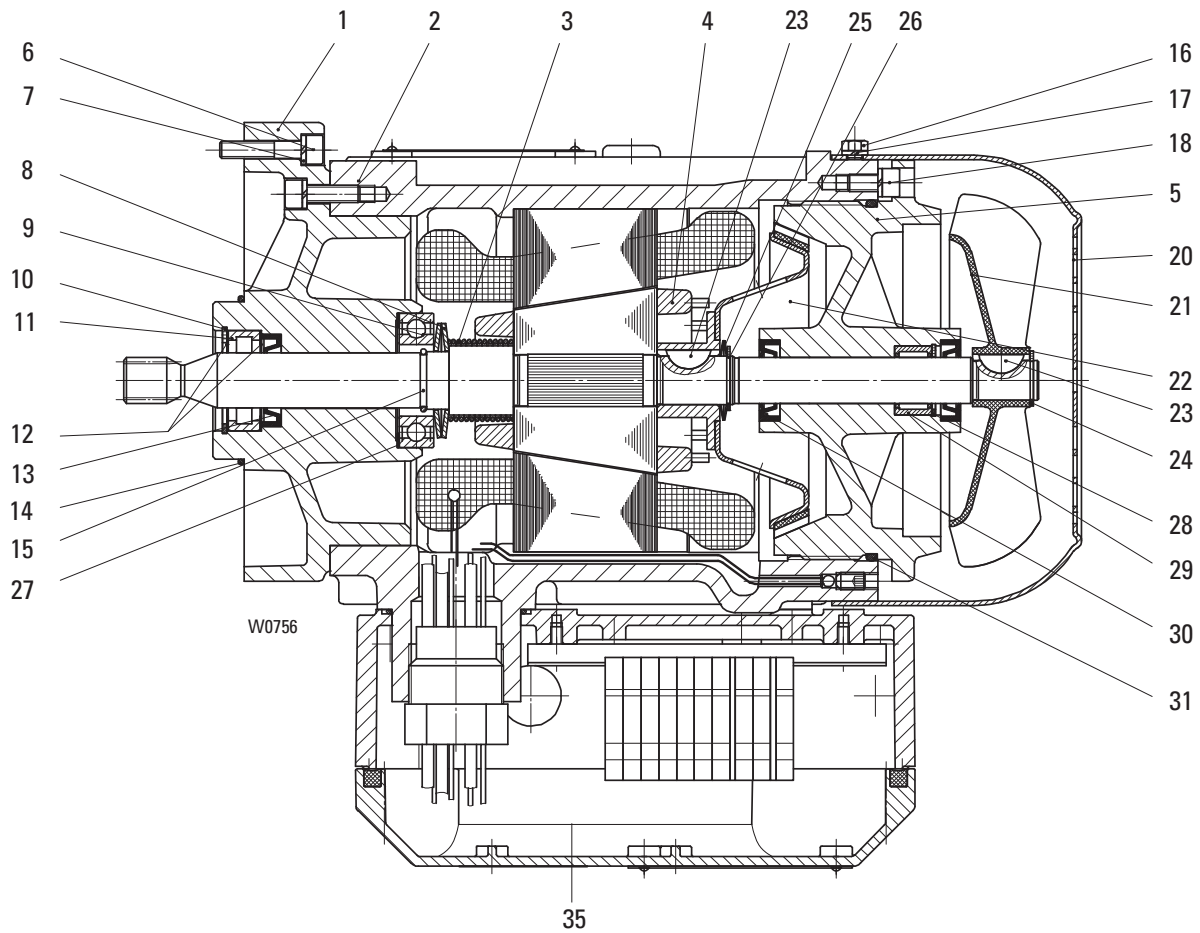

Pos	Teil-Nummer Part-Number	Stück Piece	Beschreibung Description	Benennung	Designation
22	35 330 20 18 0	1		Bremsscheibe	Brake disc
23	537 936 0	2	5x6,5 DIN 6888	Scheibenfeder	Woodruff key
24	506 890 0	1	14x1 DIN 471	Sicherungsring	Circlip
25	562 949 0	2	27,7x17,3x1,45	Tellerfeder	Cup spring
26	506 386 0	1	17x1 DIN 471	Sicherungsring	Circlip
27	507 837 0	1	37x47x0,3 DIN 988	Passscheibe	Ajusting washer
28	.....	1	M8x40 ISO 4762	Zyl-Schraube	Socket head cap screw
29	.....	1	RNA 4901 DIN 617	Nadellager	Needle roller bearing
30	.....	2	AS 16x28x7 NB	Wellendichtring	Shaft seal
31	.....	1	115x3 NB 70	Runddichtring	Round sealing ring
35	02 220 20 02 0	1		Anschlusskasten	Terminal box

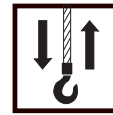

**A1 ex**  
**SF 17 ... 113**

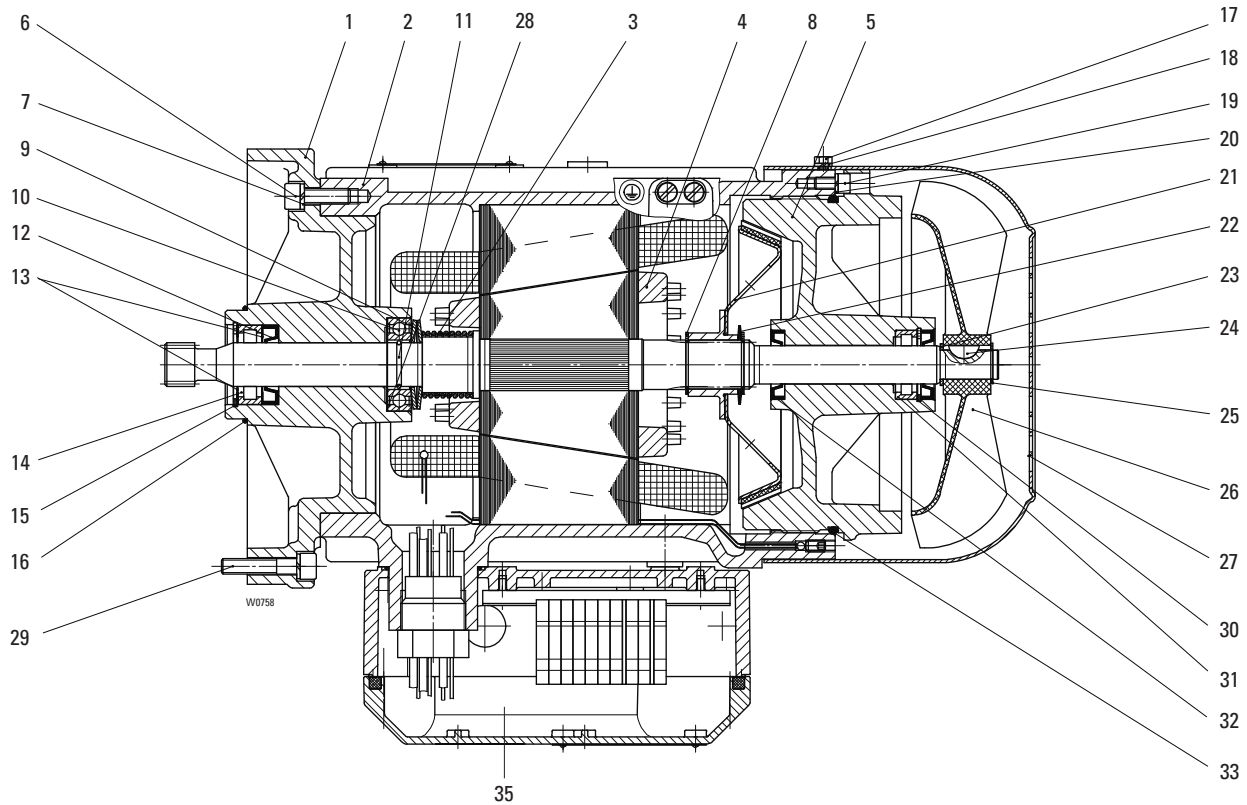

Pos	Teil-Nummer Part-Number	Stück Piece	Beschreibung Description	Benennung Designation	Designation	
	41 330 42 11 0	1	2/8A1 IIB	1) (Pos.1-33)	Motor	Motor
	41 330 43 11 0	1	2/8A1 IIC	1) (Pos.1-33)		
1	41 331 27 03 0	1	IIB		Motorflansch	Motor flange
	41 331 28 03 0	1	IIC			
2	41 330 73 14 9	1	2/8A1	1)	Stator	Stator
3	38 331 01 94 0	1			Druckfeder	Pressure spring
4	41 330 26 13 0	1			Rotor	Rotor
5	41 330 06 37 0	1	IIB	(Pos.30-32)	Motordeckel	Motor cover
	41 330 05 37 0	1	IIC	(Pos.30-32)		
	41 330 07 37 0	1	IIC	2) (Pos.30-32)		
6	500 234 0	4	M8x25	ISO 4762	Zyl-Schraube	Socket head cap
7	506 459 0	4	8	DIN 7980	Federring	Locking ring
8	506 097 0	2	25x1,2	DIN 471	Sicherungsring	Circlip
9	41 331 00 14 0	2	45x22,4x3,05x1,75		Tellerfeder	Cup spring
10	560 951 0	1	6005-2RS	DIN 625	Rillenkugellager	Grooved ball bearing
12	561 854 0	1	A22x40x8		Wellendichtring	Shaft seal
13	506 805 0	2	28x40x0,5	DIN 988	Passscheibe	Ajusting washer
14	560 844 0	1	RNU 203 E	DIN 5412	Zyl-Rollenlager	Roller bearing
15	506 262 0	1	40x1,75	DIN 472	Sicherungsring	Circlip
16	515 946 0	1	55x2	NB70	Runddichtring	Round sealing ring
17	500 419 0	4	M5x8	ISO4017	Skt-Schraube	Hexagon head cap screw
18	506 900 0	4	5	DIN 7980	Federring	Spring washer
19	500 230 0	4	M6x12	ISO 4762	Zyl-Schraube	Socket head cap screw
20	506 335 0	4	6	DIN 7980	Federring	Spring washer
21	41 330 20 18 0	1			Bremsscheibe	brake disc
22	562 939 0	2			Tellerfeder	Cup spring

1) Bitte Betriebsspannung und Frequenz angeben.  
2) hartverchromt

1) Please state operating voltage and frequency.  
2) Hard chrome plated



**Originalteile**  
**Original parts**  
**SH3 ex**

**A1 ex**  
**SF 17 ... 113**

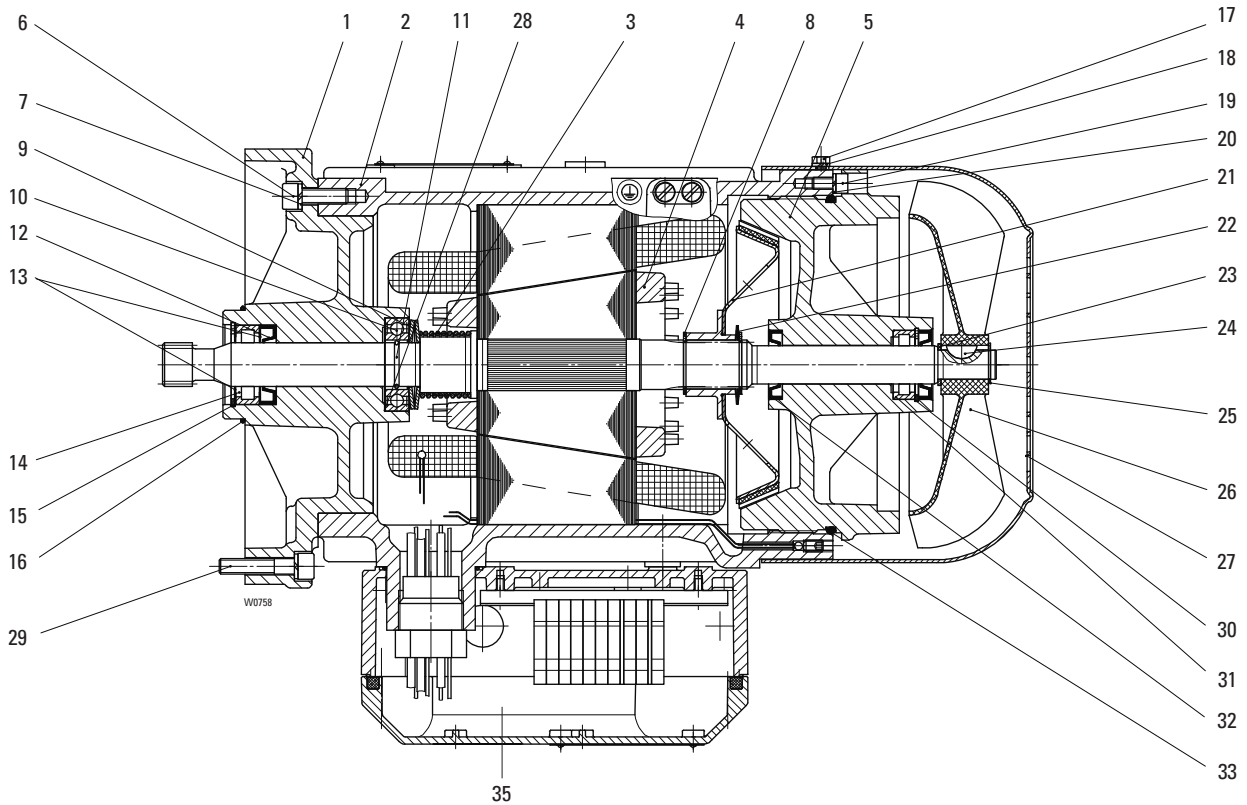

Pos	Teil-Nummer Part-Number	Stück Piece	Beschreibung Description	Benennung Designation
23	506 844 0	1	S15x21x1,5	Stützscheibe
24	537 936 0	1	5x6,5	Scheibefeder
25	506 093 0	1		Sicherungsring
26	576 030 0	1	V100 R/15	Lüfterrad
27	41 331 21 40 0	1		Lüfterhaube
28	507 837 0	1	37x47x0,3	Passscheibe
29	500 146 0	4	M8x40	Zyl-Schraube
30	... ..	1	35x1,5	Sicherungsring
31	... ..	1	RNU 202 E	Zyl-Rollenlager
32	... ..	2	A19x35x7	Wellendichtring
33	515 980 0	1	160x4	Runddichtring
35	02 220 20 02 0	1		Anschlusskasten
				Supporting ring
				Woodruff key
				Circlip
				Fan wheel
				Fan cover
				Adjusting washer
				Socket head cap screw
				Circlip
				Roller bearing
				Shaft seal
				Round sealing ring
				Terminal box



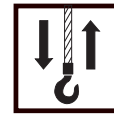

**A1 ex**  
**SF 17 ... 103**

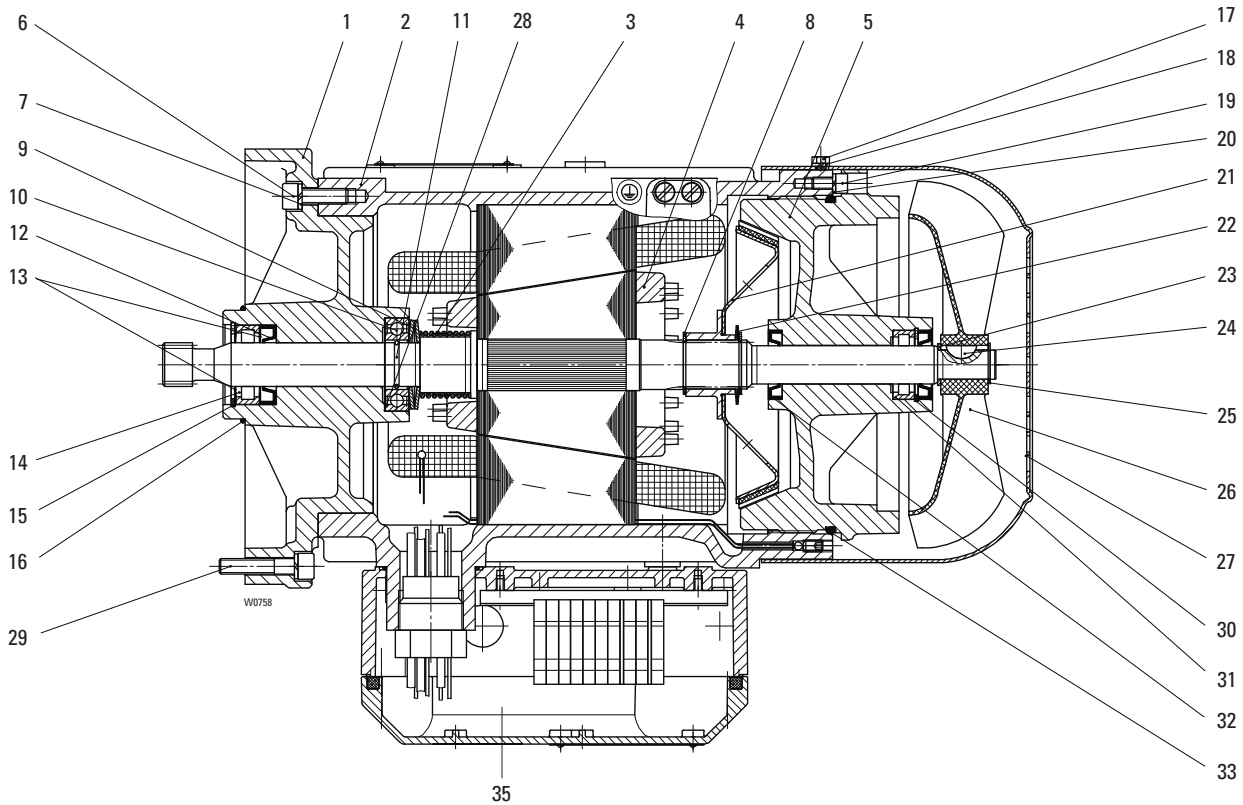

Pos	Teil-Nummer Part-Number	Stück Piece	Beschreibung Description	Benennung Designation	Designation	
	41 330 40 11 0	1	2/8A1 IIB	1) (Pos.1-33)	Motor	Motor
	41 330 41 11 0	1	2/8A1 IIC	1) (Pos.1-33)		
1	41 331 27 03 0	1	IIB		Motorflansch	Motor flange
	41 331 28 03 0	1	IIC			
2	41 330 74 14 9	1	2/8A1	1)	Stator	Stator
3	38 331 01 94 0	1			Druckfeder	Pressure spring
4	41 330 26 13 0	1			Rotor	Rotor
5	41 330 06 37 0	1	IIB	(Pos.30-32)	Motordeckel	Motor cover
	41 330 05 37 0	1	IIC	(Pos.30-32)		
	41 330 07 37 0	1	IIC	2) (Pos.30-32)		
6	500 234 0	4	M8x25	ISO 4762	Zyl-Schraube	Socket head cap
7	506 459 0	4	8	DIN 7980	Federring	Locking ring
8	506 097 0	2	25x1,2	DIN 471	Sicherungsring	Circlip
9	41 331 00 14 0	2	45x22,4x3,05x1,75		Tellerfeder	Cup spring
10	560 951 0	1	6005-2RS	DIN 625	Rillenkugellager	Grooved ball bearing
12	561 854 0	1	A22x40x8		Wellendichtring	Shaft seal
13	506 805 0	2	28x40x0,5	DIN 988	Passscheibe	Adjusting washer
14	560 844 0	1	RNU 203 E	DIN 5412	Zyl-Rollenlager	Roller bearing
15	506 262 0	1	40x1,75	DIN 472	Sicherungsring	Circlip
16	515 946 0	1	55x2	NB70	Runddichtring	Round sealing ring
17	500 419 0	4	M5x8	ISO4017	Skt-Schraube	Hexagon head cap screw
18	506 900 0	4	5	DIN 7980	Federring	Spring washer
19	500 230 0	4	M6x12	ISO 4762	Zyl-Schraube	Socket head cap screw
20	506 335 0	4	6	DIN 7980	Federring	Spring washer
21	41 330 20 18 0	1			Bremsscheibe	brake disc
22	562 939 0	2			Tellerfeder	Cup spring

1) Bitte Betriebsspannung und Frequenz angeben.  
2) hartverchromt

1) Please state operating voltage and frequency.  
2) Hard chrome plated



Originalteile  
Original parts  
SH3 ex

A1 ex  
SF 17 ... 103

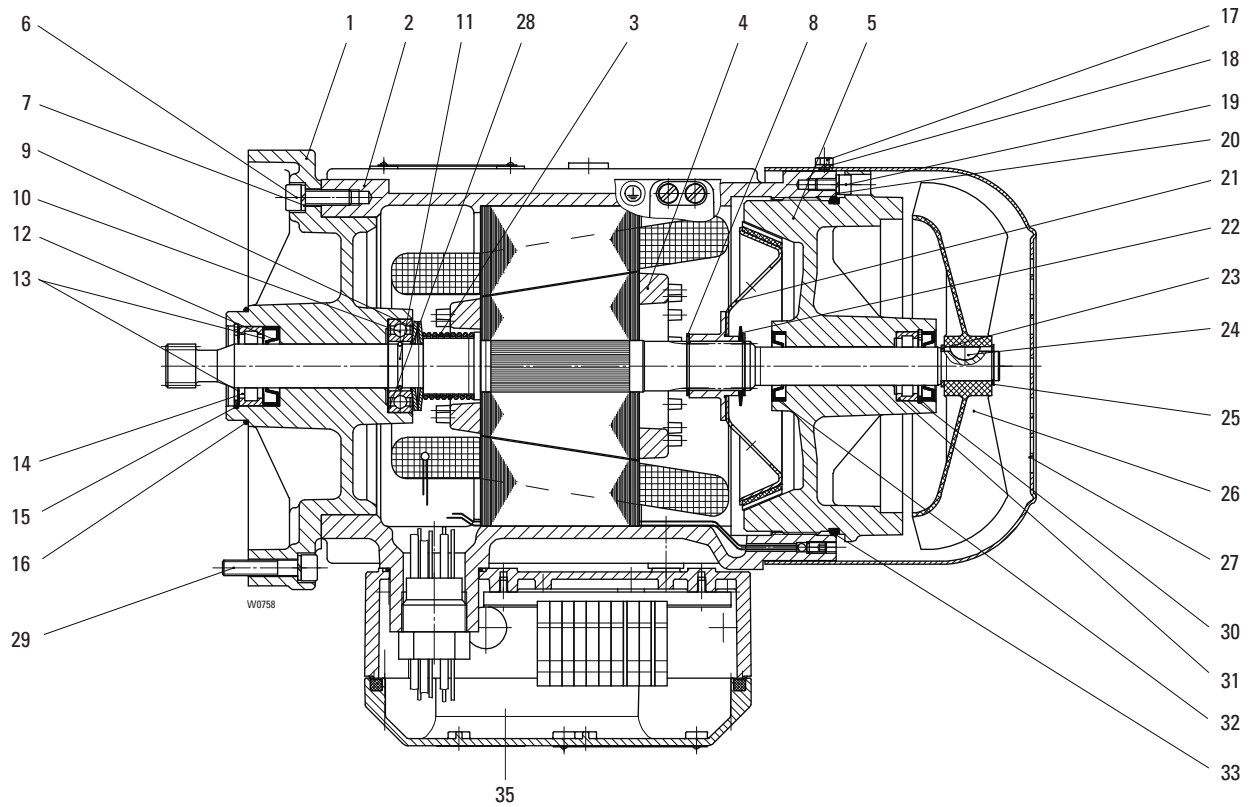

Pos	Teil-Nummer Part-Number	Stück Piece	Beschreibung Description	Benennung Designation
23	506 844 0	1	S15x21x1,5	Stützscheibe
24	537 936 0	1	5x6,5	Scheibenfeder
25	506 093 0	1		Sicherungsring
26	576 030 0	1	V100 R/15	Lüfterrad
27	41 331 21 40 0	1		Lüfterhaube
28	507 837 0	1	37x47x0,3	Passscheibe
29	500 146 0	4	M8x40	Zyl-Schraube
30	...	1	35x1,5	Sicherungsring
31	...	1	RNU 202 E	Zyl-Rollenlager
32	...	2	A19x35x7	Wellendichtring
33	515 980 0	1	160x4	Runddichtring
35	02 220 20 02 0	1		Anschlusskasten
				Supporting ring
				Woodruf key
				Circlip
				Fan wheel
				Fan cover
				Ajusting washer
				Socket head cap screw
				Circlip
				Roller bearing
				Shaft seal
				Round sealing ring
				Terminal box

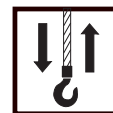

SF 17 2..

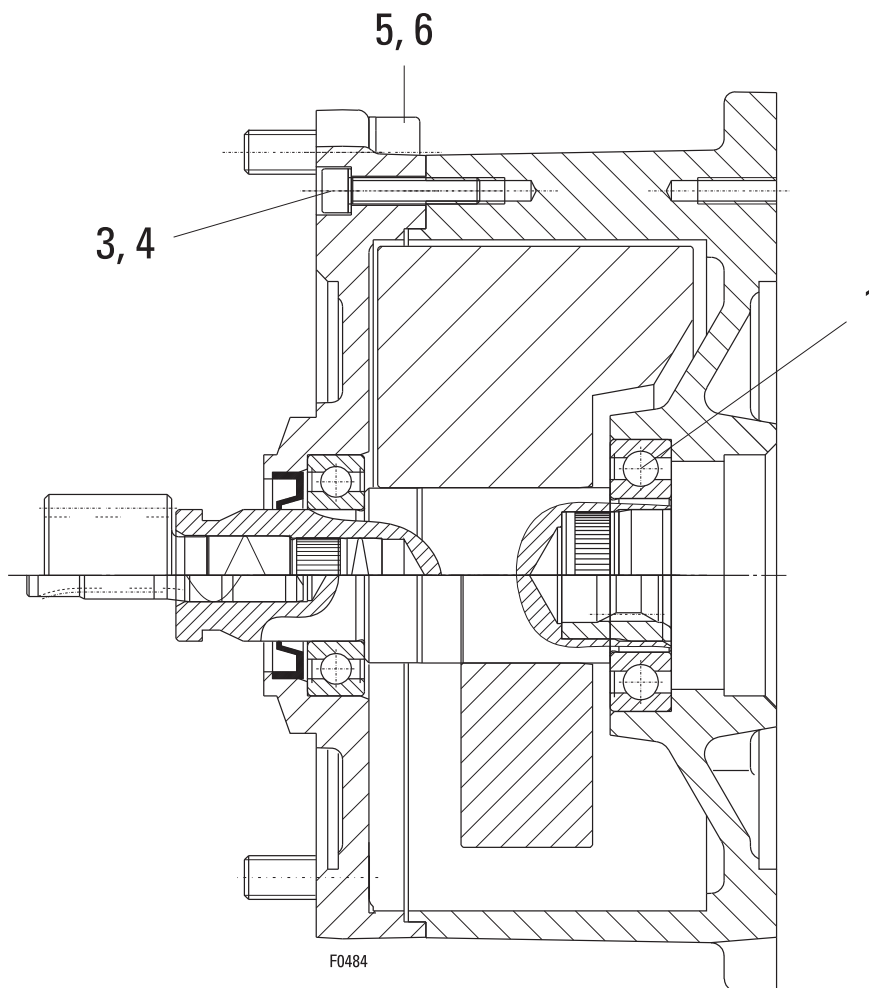

Pos	Teil-Nummer Part-Number	Stück Piece	Beschreibung Description	Benennung	Designation		
	21 270 10 32 0	1	SF 17 219 503	Schwungradkupplung	Flywheel coupling		
	21 270 11 32 0	1	SF 17 217 503				
	21 270 12 32 0	1	SF 17 215 503				
	21 270 13 32 0	1	SF 17 213 503				
	21 270 14 32 0	1	SF 17 211 503				
	21 270 15 32 0	1	SF 17 209 503				
	21 270 16 32 0	1	SF 17 207 503				
	21 270 18 32 0	1	SF 17 217 113				
	21 270 19 32 0	1	SF 17 215 113				
	21 270 20 32 0	1	SF 17 213 113				
	21 270 21 32 0	1	SF 17 211 113				
	21 270 22 32 0	1	SF 17 209 113				
	21 270 23 32 0	1	SF 17 207 113				
	21 270 28 32 0	1	SF 17 211 103				
	21 270 29 32 0	1	SF 17 209 103				
	21 270 30 32 0	1	SF 17 207 103				
1	560 989 0	1	6007-2Z DIN 625			Rillenkugellager	Grooved ball bearing
3	500 976 0	8	M6x30 ISO 4762-8.8			Zyl-Schraube	Socket head cap screw
4	506 838 0	8	S6			Sicherungsscheibe	Lock washer
5	500 236 0	4	M10x30 DIN 912-8.8			Zyl-Schraube	Socket head cap screw
6	506 128 0	4	VS10	Sicherungsscheibe	Lock washer		



**Originalteile**  
**Original parts**  
**SF3 ex**

SF 17 2..

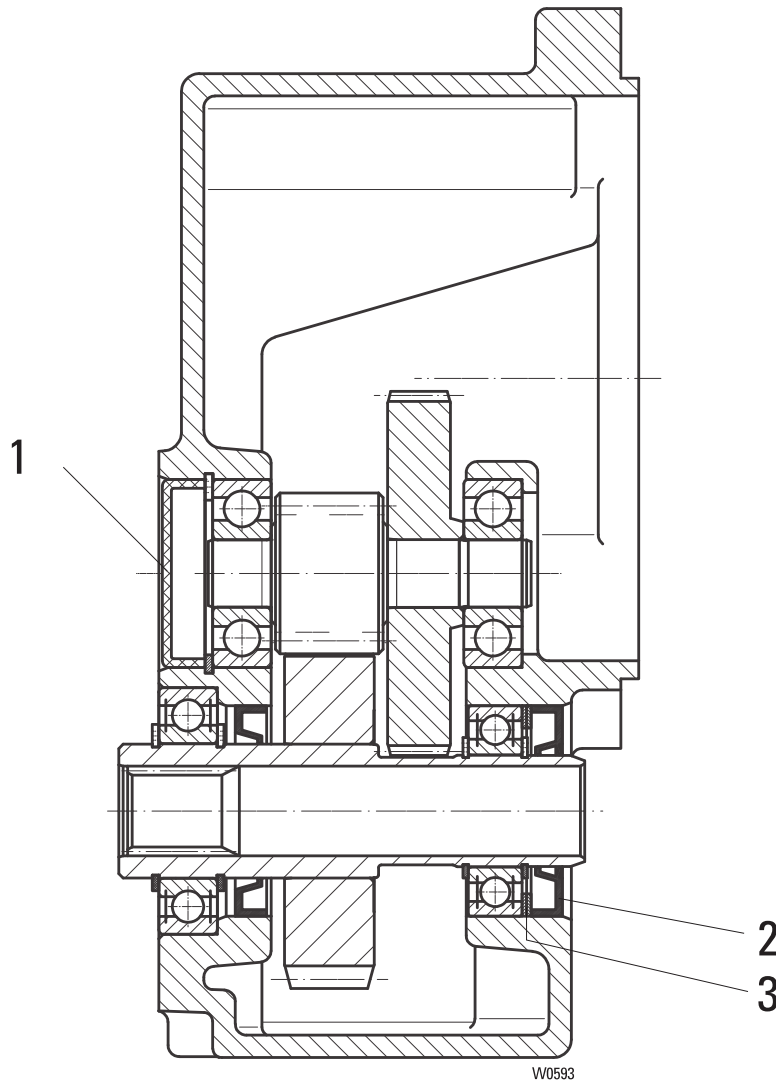

Pos	Teil-Nummer Part-Number	Stück Piece	Beschreibung Description	Benennung	Designation
	21 270 04 30 0	1	SF17 219	Getriebe	Gear
	21 270 05 30 0	1	SF17 217		
	21 270 06 30 0	1	SF17 215		
	21 270 07 30 0	1	SF17 213		
	21 270 08 30 0	1	SF17 211		
	21 270 09 30 0	1	SF17 209		
	21 270 10 30 0	1	SF17 207		
1	518 036 0	1	42x9,5		
2	561 120 0	1	25x47x7	Wellendichtring	Shaft seal
3	507 876 0	2	37x47x1	Passscheibe	Adjusting washer

Getriebe nur komplett lieferbar.  
 Ohne Getriebeöl: Erforderliche Menge siehe Betriebsanleitung

Gear only available as complete unit.  
 Without gear oil: amount required see operating instruction

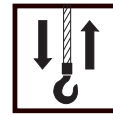

SF 17

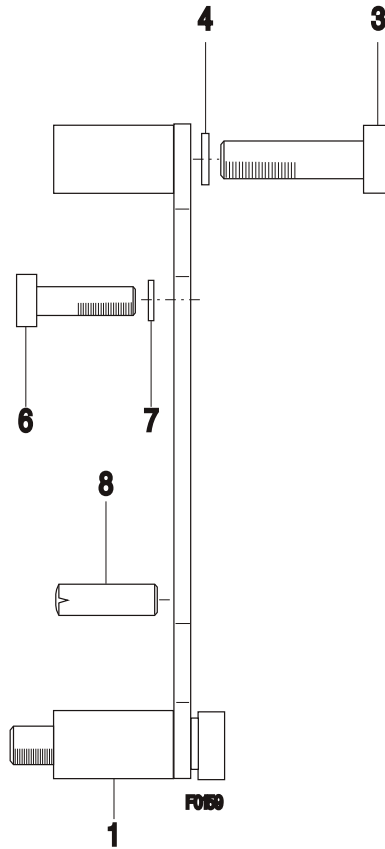

Pos	Teil-Nummer Part-Number	Stück Piece	Beschreibung Description	Benennung	Designation
1	21 270 01 22 0	1	SF1 (Pos.3-8)	Drehmomentstütze	Torque support
3	500 980 0	4	M8x45 DIN 912-8.8	Zyl-Schraube	Socket head cap screw
4	506 839 0	4	S8	Sicherungsscheibe	Locking disc
6	500 144 0	4	M8x16 DIN 912-8.8	Zyl-Schraube	Socket head screw
7	506 839 0	4	S8	Sicherungsscheibe	Locking disc
8	504 960 0	2	8m6x24 DIN 7	Zyl-Stift	Pin



**Originalteile**  
**Original parts**  
**SH3 ex**

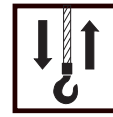

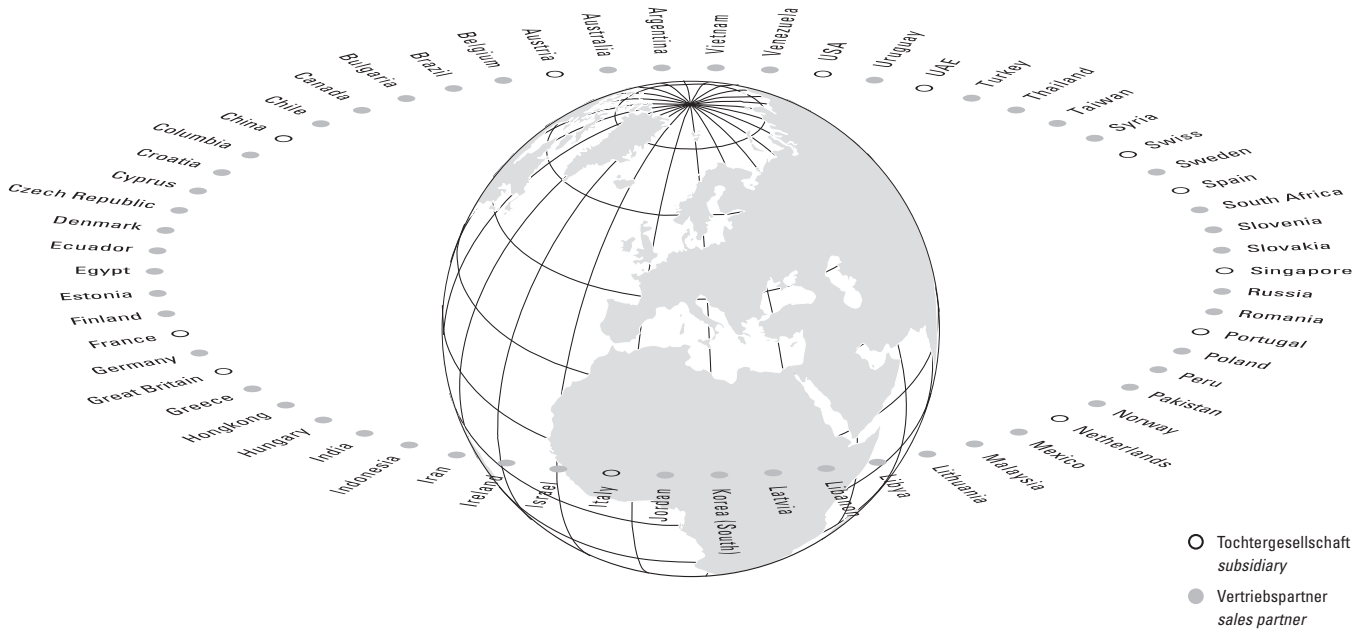

Europe		T	F	E
Austria	Steyregg	+43 732 641111-0	+43 732 641111-33	office@stahlcranes.at
France	Paris	+33 1 39985060	+33 1 34111818	info@stahlcranes.fr
Great Britain	Birmingham	+44 121 7676414	+44 121 7676490	info@stahlcranes.co.uk
Italy	S. Colombano	+39 0185 358391	+39 0185 358219	info@stahlcranes.it
Netherlands	EL Haarlem	+31 23 51252-20	+31 23 51252-23	info@stahlcranes.nl
Portugal	Lissabon	+351 21 44471-61	+351 21 44471-69	ferrometal@ferrometal.pt
Spain	Madrid	+34 91 484-0865	+34 91 490-5143	info@stahlcranes.es
Switzerland	Däniken	+41 62 82513-80	+41 62 82513-81	info@stahlcranes.ch

America/Asia		T	F	E
China	Shanghai	+86 21 6257 2211	+86 21 6254 1907	victor.low@stahlcranes.cn
India	Chennai	+91 44 4352-3955	+91 44 4352-3957	anand@stahlcranes.in
Singapore	Singapore	+65 6271 2220	+65 6377 1555	sales@stahlcranes.sg
U.A.E.	Dubai	+971 4 805-3700	+971 4 805-3701	info@stahlcranes.ae
USA	Charleston, SC	+1 843 767-1951	+1 843 767-4366	sales@stahlcranes.us

Россия ООО "КранШталь" 109451, г.Москва, ул. Верхние поля, д.28  
тел./факс: +7 495 2253788 +7 495 9214517 info@stahlcranes.ru

→ [www.kranstahl.ru](http://www.kranstahl.ru)  
→ [www.tali-market.ru](http://www.tali-market.ru)

→ [www.servis-kran.ru](http://www.servis-kran.ru)  
→ [www.stahlcranes.ru](http://www.stahlcranes.ru)

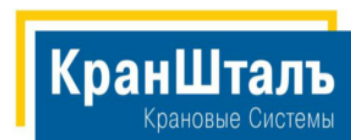

Partner of

